

SawStop[®]

T-Glide™ Fence System- Professional Series II

OWNER'S MANUAL

Model TGP2-FA



Warranty

SawStop warrants to the original retail purchaser of a new T-Glide Fence System - Professional Series II from an authorized SawStop distributor that the fence system will be free from defects in material and workmanship for ONE YEAR from the date of purchase. SawStop warrants to the original retail purchaser of a refurbished, demonstration or floor model T-Glide Fence System - Professional Series II from an authorized SawStop distributor that the fence system will be free from defects in material and workmanship for SIX MONTHS from the date of purchase.

This warranty does not apply to defects arising from misuse, abuse, negligence, accidents, normal wear-and-tear, unauthorized repair or alteration, or lack of maintenance. This warranty is void if the fence system or any portion of the fence system is modified without the prior written permission of SawStop, LLC, or if the fence system is located or has been used outside of the country where the authorized SawStop distributor from whom the fence system was purchased resides.

Please contact SawStop to take advantage of this warranty. If SawStop determines the fence system is defective in material or workmanship, and not due to misuse, abuse, negligence, accidents, normal wear-and-tear, unauthorized repair or alteration, or lack of maintenance, then SawStop will, at its expense and upon proof of purchase, send replacement parts to the original retail purchaser necessary to cure the defect. Alternatively, SawStop will repair the fence system provided it is returned to SawStop, shipping prepaid, with proof of purchase and within the warranty period.

SawStop disclaims any and all other express or implied warranties, including merchantability and fitness for a particular purpose. SawStop shall not be liable for death, injuries to persons or property, or incidental, consequential, contingent or special damages arising from the use of the fence system.

This warranty gives you specific legal rights. You may have other rights which, in the United States, vary from state to state.

Safety

1. You **MUST** install a rip fence before using your saw. Using the saw without a rip fence could result in serious personal injury.
2. Never perform a ripping operation freehand or a serious injury may result.
3. Always use a push stick or push block when your hand comes within 6 inches of the blade. Attempting to use the rip fence for narrow cuts without a push stick or push block could result in a serious injury.
4. Do not use the miter gauge when making rip cuts.
5. While making bevel cuts, use the fence only on the right side of the saw blade to prevent the blade from possibly contacting the fence. The brake will activate if the spinning saw blade contacts the metal in the fence.

Unpacking Your T-Glide Fence System

While unpacking your saw, verify that you have all the components shown below for your specific fence system. The T-Glide Fence System – Professional Series II is available in either a 52” system or a 36” system. Although the components pictured below are from the 52” system, the components from the 36” system are similar.

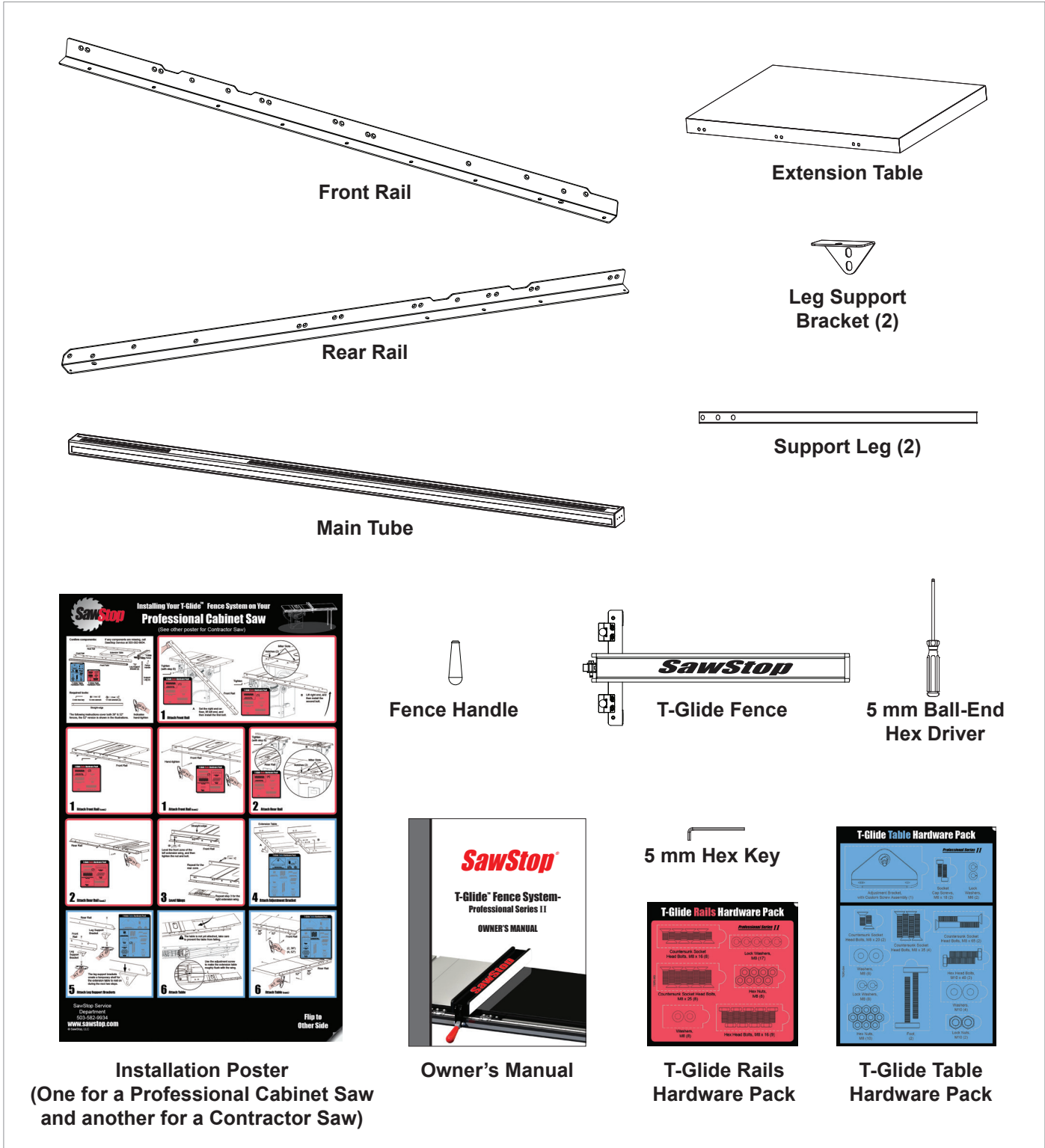

Fig. 1

Installing Your T-Glide Fence System

Note: Your saw must be fully assembled before installing the fence system.

Before you begin installing the fence system, locate the front rail, the rear rail, and the T-Glide Rails Hardware Pack (). All of the hardware needed to install the rails is located on the T-Glide Rails Hardware Pack and is shipped in the T-Glide fence box. In order to easily identify the hardware used in each of the following steps, the different pieces of hardware are numbered on the hardware pack and in the figures. If you are missing the T-Glide Rails Hardware Pack, the T-Glide Table Hardware Pack, or any of the other fence system components shown in **Fig. 1**, call the SawStop Service Department at 503-582-9934.

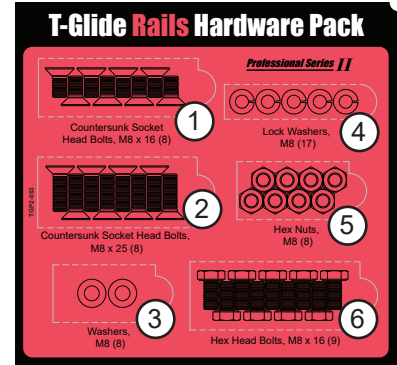

Fig. 2

You will also need the following tools to complete the fence assembly:

- 13 mm wrench
- 17 mm wrenches (2) (or adjustable wrenches)
- 5 mm hex key
- Level or straight-edge

Note: The drawings below show how to assemble both the 52" and 36" fence systems. Although the components shown are from the 52" fence system, the components from the 36" system are similar.

The instructions for installing rails on a SawStop Professional Cabinet Saw are different from the instructions for a SawStop Contractor Saw. The instructions for installing the extension table are the same for the Professional Cabinet Saw and the Contractor Saw.

If you have a SawStop Professional Cabinet Saw

- Begin on page 3.

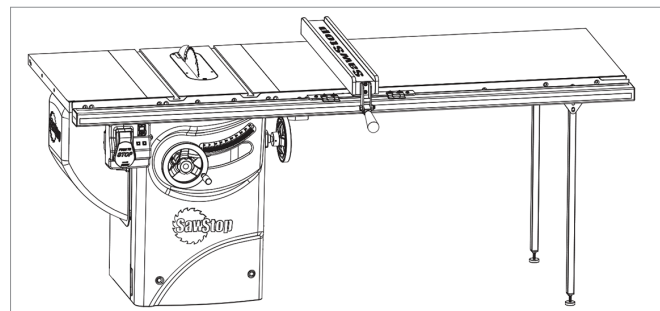

If you have a SawStop Contractor Saw

- Begin on page 8.

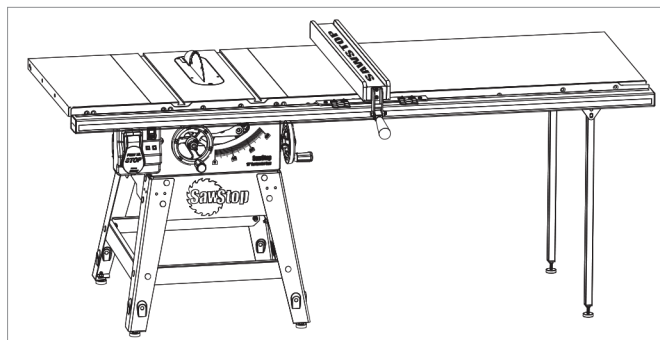

Installing Your T-Glide Fence System



1. Begin mounting the front rail (the longer of the two rails) to the front edge of your saw by centering the notches in the rail with the two miter slots in the table, aligning the two holes in the rail between the notches with the two corresponding holes in the front edge of the table, and threading an M8 x 16 countersunk socket head bolt (1) into each hole (See Fig. 3). Aligning the two holes between the notches aligns all the other holes used in mounting the rail to your saw. Not all the holes are used to mount the rail to your saw; different holes are used for different saws. Thread the bolts into the corresponding holes, and tighten them using a 5 mm hex key.

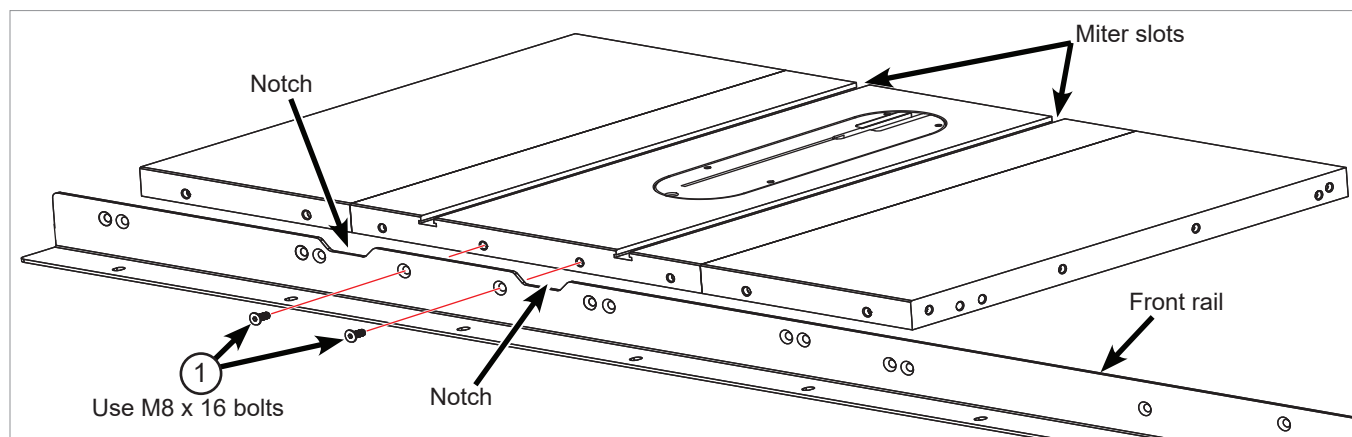

Installing Your T-Glide Fence System

Professional Cabinet Saw

2. Take two more M8 x 16 countersunk socket head bolts (1) and thread one into the hole to the right of the notches and the other into the hole to the left of the notches (See Fig. 4). Tighten the bolts with a 5 mm hex key.

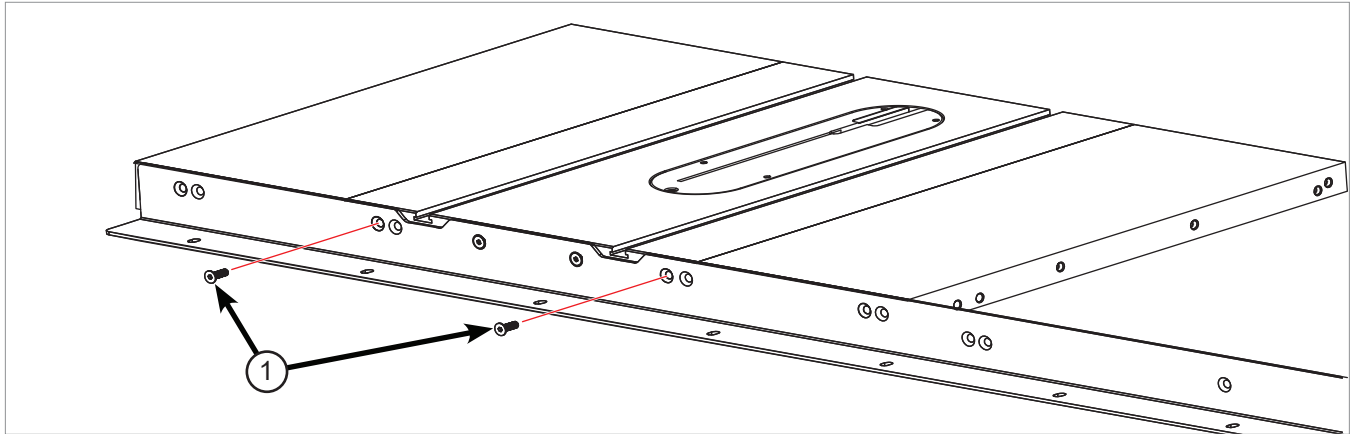

Fig. 4

Installing Your T-Glide Fence System

Professional Cabinet Saw

3. Take two M8 x 25 countersunk socket head bolts (2) and insert one bolt through the corresponding hole in the end of each extension wing. Place an M8 washer (3), an M8 lock washer (4), and an M8 hex nut (5) on the threaded end of each of the bolts (See Fig. 5). Hand tighten the nuts; do not fully tighten them.

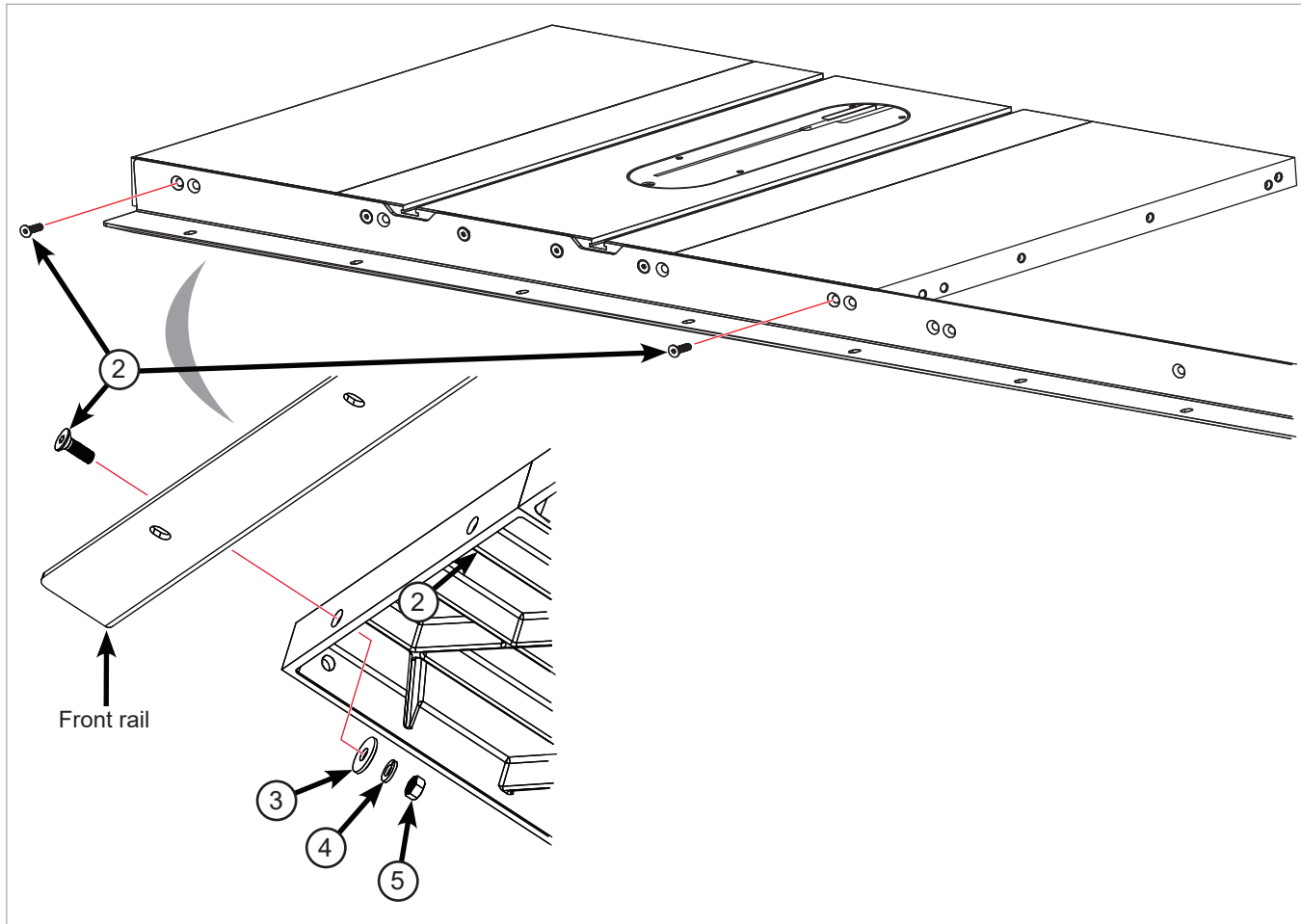

Fig. 5

Installing Your T-Glide Fence System

Professional Cabinet Saw

4. Begin mounting the rear rail (the shorter of the two rails) to the rear edge of your saw by centering the notches in the rail with the two miter slots in the table and aligning the left-most hole between the notches with the corresponding hole in the rear edge of the table (See Fig. 6). There are three holes in the rail between the notches, one solitary hole and two holes paired together, and the left-most hole is the solitary hole. Not all the holes are used to mount the rail to your saw; different holes are used for different saws. Aligning the left-most hole aligns all the other holes used in mounting the rail to your saw. When the holes are aligned, mount the rail to the saw by threading an M8 x 16 countersunk socket head bolt (1) into each of the four open holes in the rear edge of the table and tighten the bolts using a 5 mm hex key.

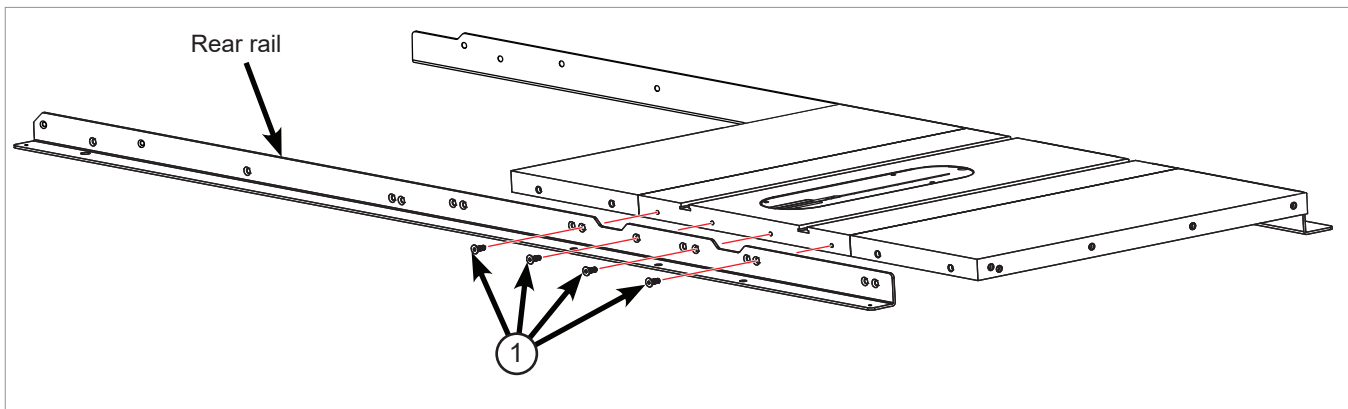

Fig. 6

5. Finish mounting the rear rail to your saw by inserting an M8 x 25 countersunk socket head bolt (2) through the open hole at the end of each extension wing, and placing an M8 washer (3), an M8 lock washer (4), and an M8 hex nut (5) on the threaded end of each bolt (See Fig. 7). Hand tighten the nuts; do not fully tighten them.

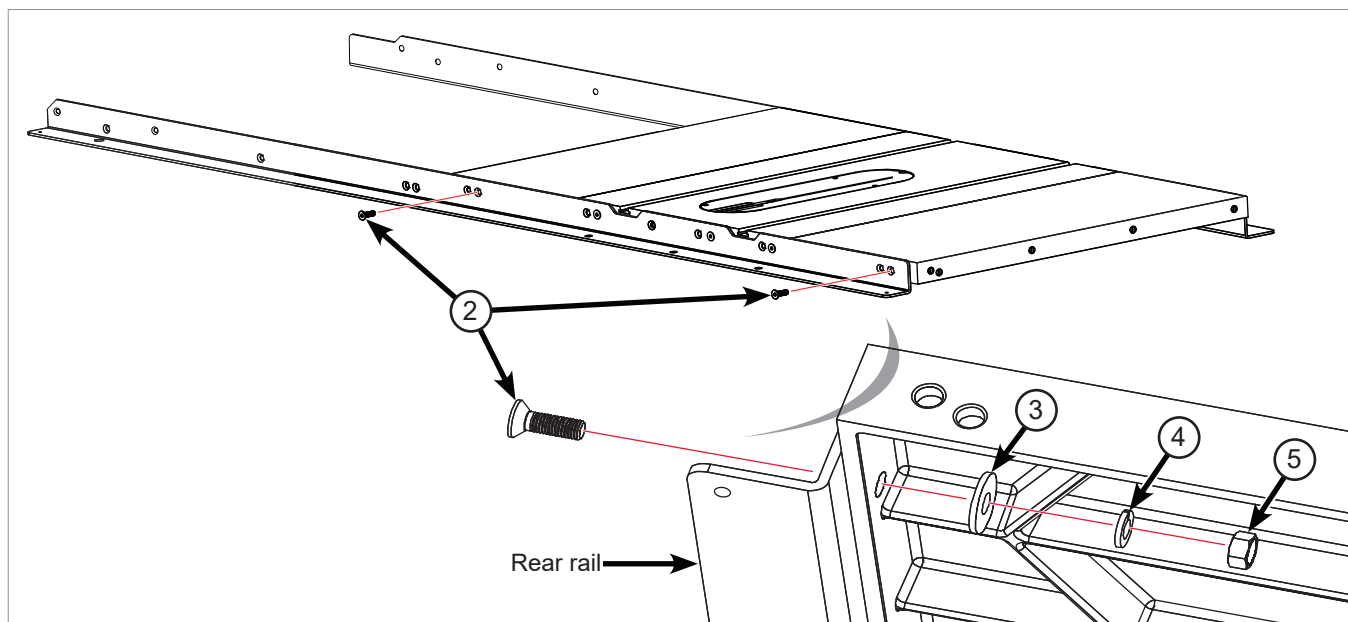

Fig. 7

Installing Your T-Glide Fence System

Professional Cabinet Saw

6. Use a straight-edge to level the front edge of the left extension wing to the cast iron table top (**See Fig. 8**). You may have to pull up or push down on the outer edge of the extension wing to level it. Once the front edge of the left extension wing is level, use a 5 mm hex key and a 13 mm wrench to fully tighten the nut on the bolt that mounts the left extension wing to the front rail. Repeat this process to level the front edge of the right extension wing and the rear edges of the left and right extension wings.

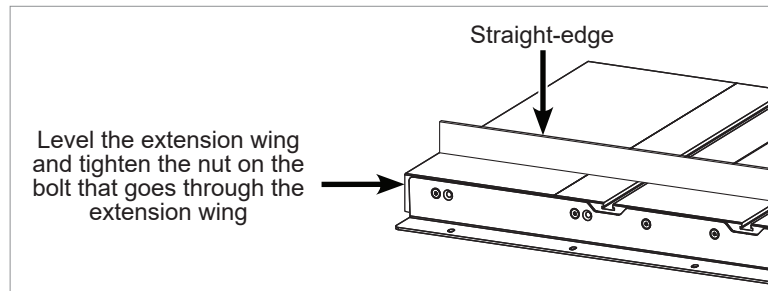

Fig. 8

Installing Your T-Glide Fence System



1. Begin mounting the front rail (the longer of the two rails) to the front edge of your saw by centering the notches in the rail with the two miter slots in the table, aligning the two holes in the rail between the notches with the two corresponding holes in the front edge of the table, and inserting an M8 x 25 countersunk socket head bolt (2) into each hole. Aligning the two holes between the notches aligns all the other holes used in mounting the rail to your saw. Not all the holes are used to mount the rail to your saw; different holes are used for different saws. Insert the bolts one at a time, placing an M8 washer and an M8 lock washer on the threaded end of each bolt and then threading on an M8 hex nut (See Fig. 9). Hand tighten the nuts; do not fully tighten them.

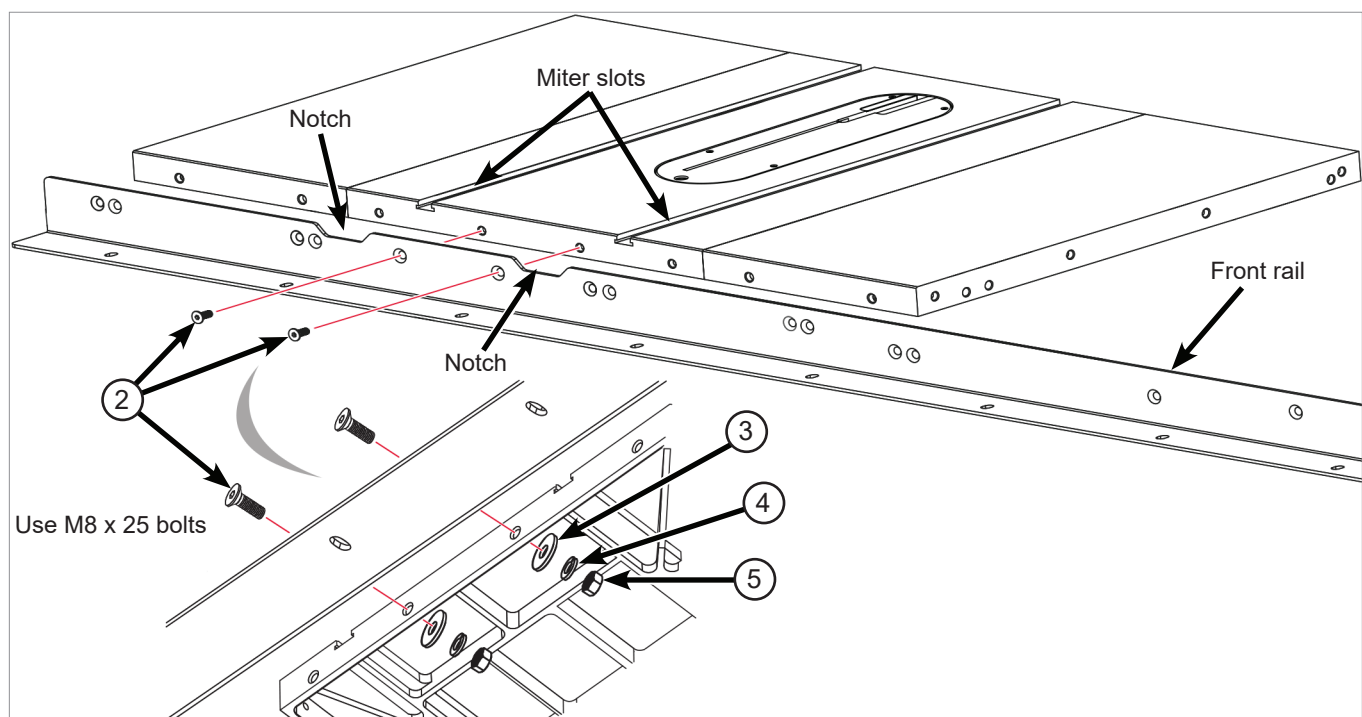

Fig. 9

Installing Your T-Glide Fence System

Contractor Saw

2. Take four more M8 x 25 countersunk socket head bolts and insert them through the four open holes in the front rail and table. Place an M8 washer and an M8 lock washer on the threaded end of each of the bolts and then thread an M8 hex nut on each bolt (See Fig. 10). Hand tighten the nuts; do not fully tighten them.

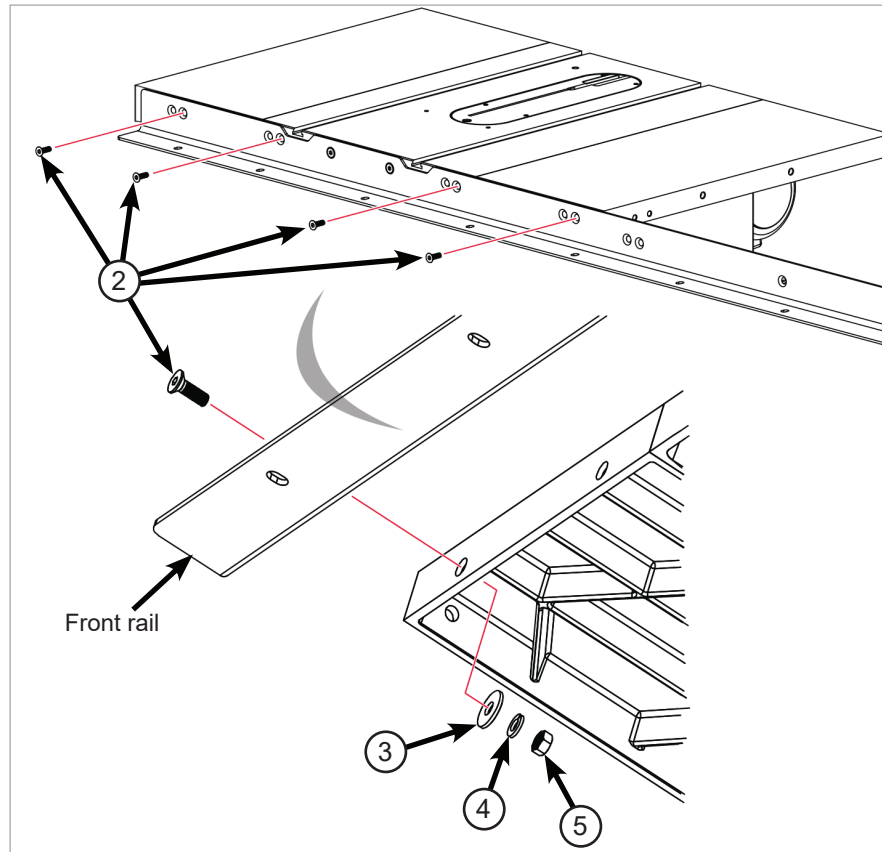

Fig. 10

Installing Your T-Glide Fence System

Contractor Saw

- The holes in the front edge of the table and extension wings are slightly larger than the bolts they receive to allow you to level the front rail and extension wings to the table top. Align the top of the front rail with the lower edge of the bevel on the front edge of the table top (See Fig. 11). Use a 5 mm hex key and a 13 mm wrench to fully tighten the nuts on the back of the four bolts that extend through the table top. Do not tighten the nuts on the bolts that extend through the extension wings.

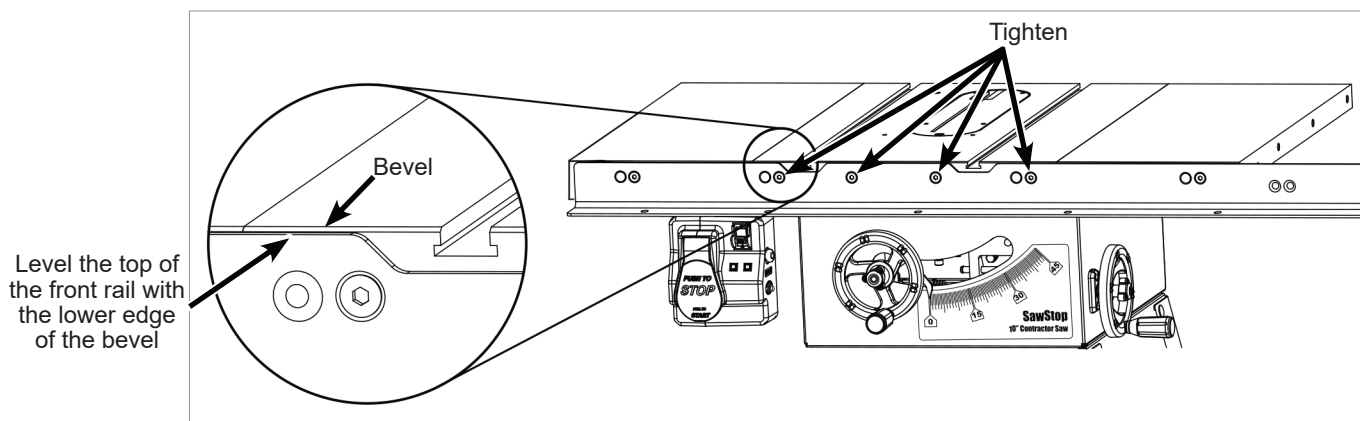

Fig. 11

- Begin mounting the rear rail (the shorter of the two rails) to the rear edge of your saw by centering the notches in the rail with the two miter slots in the table and aligning the left-most hole between the notches with the corresponding hole in the rear edge of the table. There are three holes in the rail between the notches, one solitary hole and two holes paired together, and the left-most hole is the solitary hole. Not all the holes are used to mount the rail to your saw; different holes are used for different saws. Aligning the left-most hole aligns all the other holes used in mounting the rail to your saw. When the holes are aligned, mount the rail to the saw by threading an M8 x 16 countersunk socket head bolt into each of the four open holes in the rear edge of the table and tighten the bolts using a 5 mm hex key (See Fig. 12).

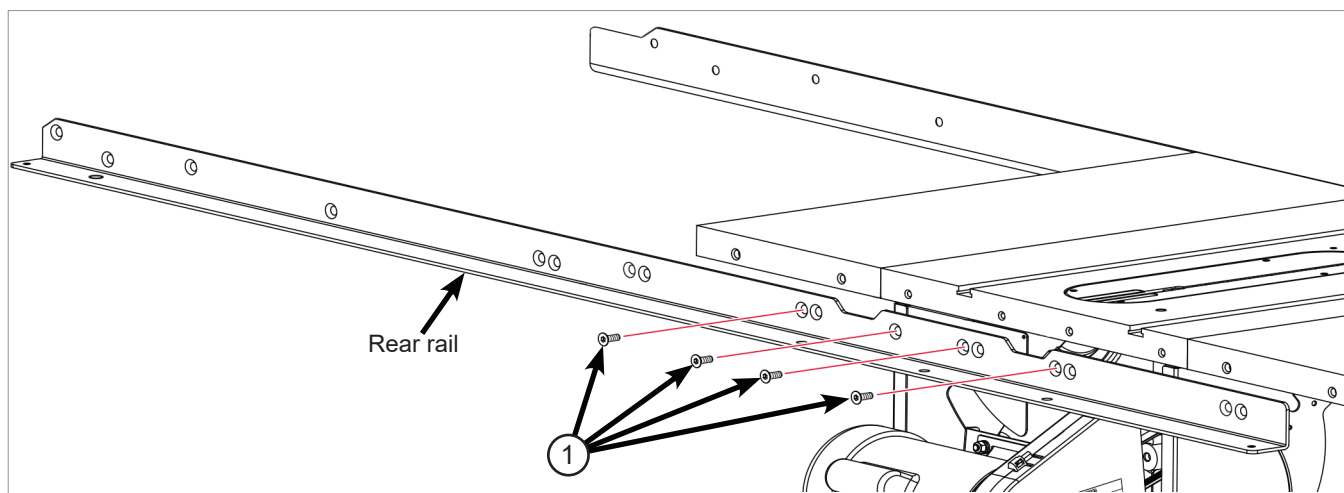

Fig. 12

Installing Your T-Glide Fence System

Contractor Saw

5. Finish mounting the rear rail to your saw by inserting an M8 x 25 (2) countersunk socket head bolt through the open hole at the end of each extension wing, and placing an M8 washer, an M8 lock washer, and an M8 hex nut on the threaded end of each bolt (See Fig. 13). Hand tighten the nuts; do not fully tighten them.

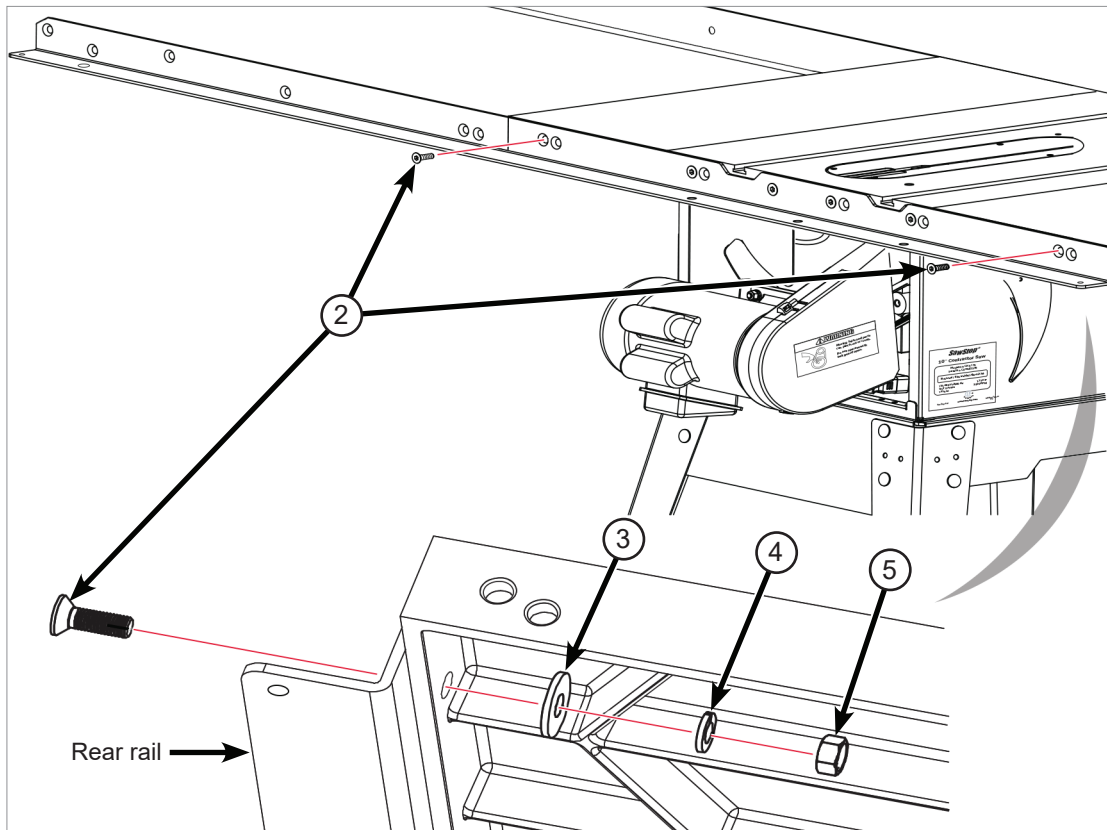

Fig. 13

6. Use a straight-edge to level the front edge of the left extension wing to the cast iron table top (See Fig. 14). You may have to pull up or push down on the outer edge of the extension wing to level it. Once the front edge of the left extension wing is level, use a 5 mm hex key and a 13 mm wrench to fully tighten the nut on the bolt that mounts the left extension wing to the front rail. Repeat this process to level the front edge of the right extension wing and the rear edges of the left and right extension wings.

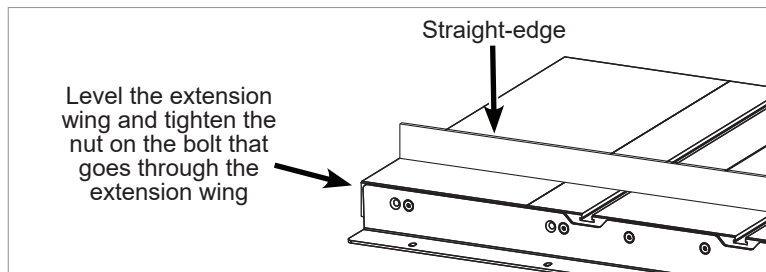

Fig. 14

Installing Your T-Glide Fence System

- Once the rails are in place you can mount the extension table to the rails. The hardware needed to mount the extension table to the rails is in the T-Glide Table Hardware Pack (See Fig. 15).

The instructions for installing the extension table and the fence (steps 7-22) are the same for both the Professional Cabinet Saw and the Contractor Saw.

The first step in mounting the extension table is to install the adjustment bracket (13) included in the T-Glide Table Hardware Pack. Remove the adjustment bracket, two M6 x 18 socket cap screws (14), and two M6 lock washers (15) from the T-Glide Table Hardware Pack, and place a lock washer on each screw. One end of the extension table includes two holes and the adjustment bracket has two corresponding holes. Position the adjustment bracket against the inside edge of the extension table, align the holes, and thread the screws into the holes (See Fig. 16). Tighten the screws with a 5 mm hex key.

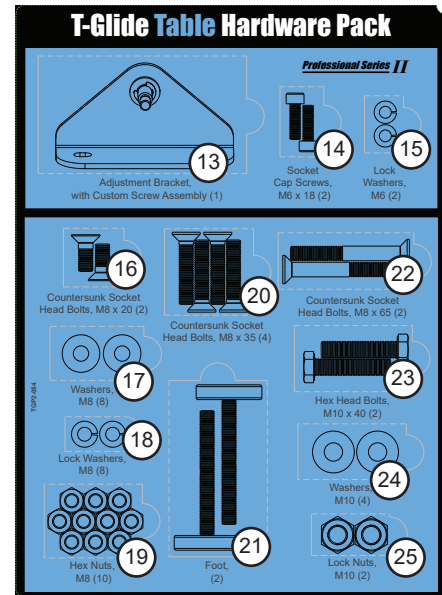

Fig. 15

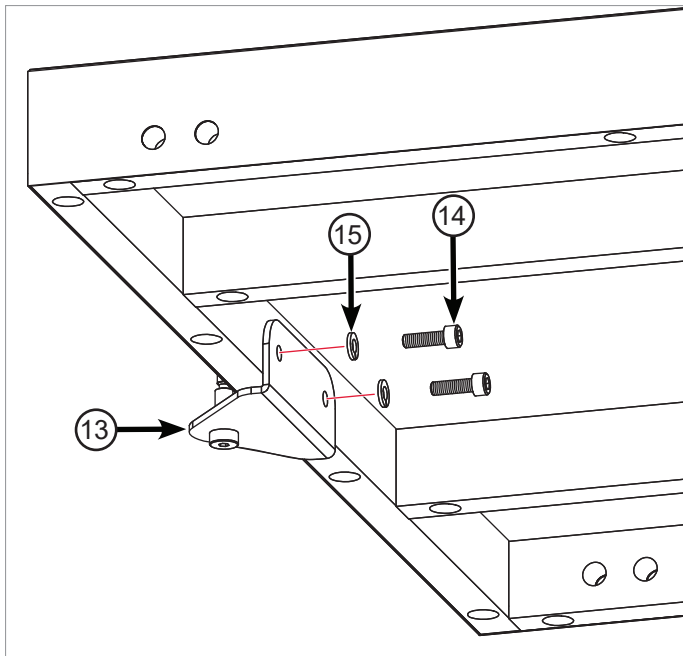

Fig. 16

NOTE: The adjustment bracket is designed for cast iron wings only. If you have a Contractor Saw with stamped wings, you may skip this step and go on to step 8.

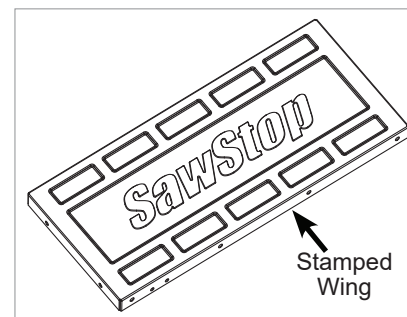

Fig. 17

Installing Your T-Glide Fence System

8. Locate the two leg support brackets. Remove the two M8 x 20 countersunk socket head bolts (16) from the T-Glide Table Hardware Pack along with two M8 washers (17), two M8 lock washers (18) and two M8 hex nuts (19). Mount one leg support bracket to the underside of each of the rails (See Fig. 18). Hand tighten the nuts; do not fully tighten them.

Once mounted, the brackets should create a shelf as shown in the detail view of Fig. 18.

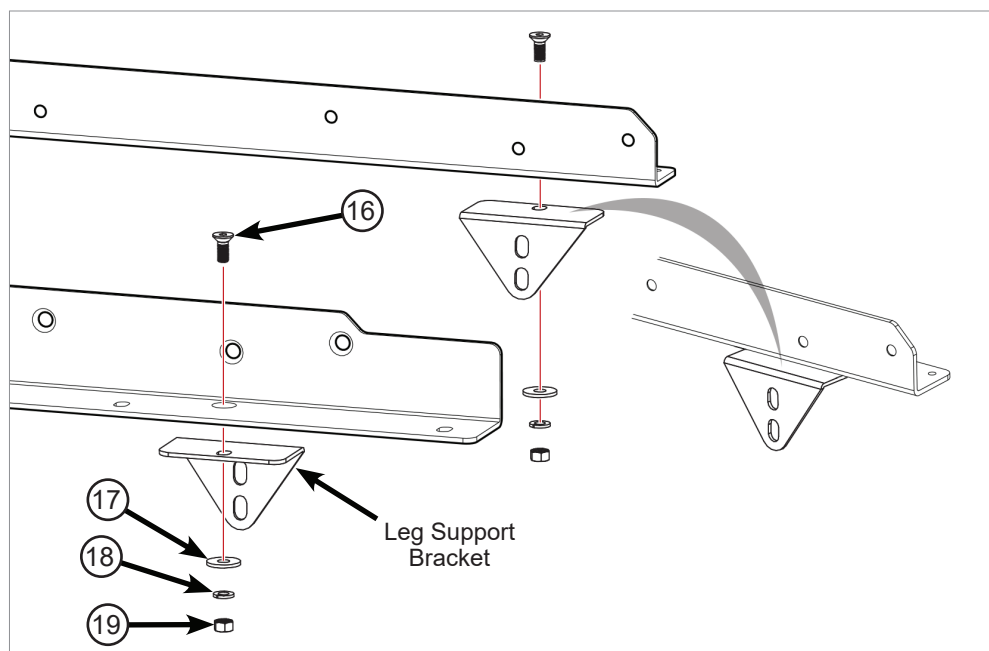

Fig. 18

9. Place the extension table between the rails and slide it towards the extension wing (See Fig. 19). Be careful when positioning the extension table because it is not yet secured to the rails and could fall. You will need to tilt the extension table slightly for the adjustment bracket to fit under the extension wing. The adjustment bracket includes a screw that extends upward and the underside of the extension wing includes a hole to receive the screw. Fit the screw into the hole, and then turn the screw until the extension table is roughly flush with the extension wing. The opposite end of the extension table will rest upon the leg support brackets but will not be level because the leg support brackets are at different elevations and are not intended to support the extension table once it is fully installed.

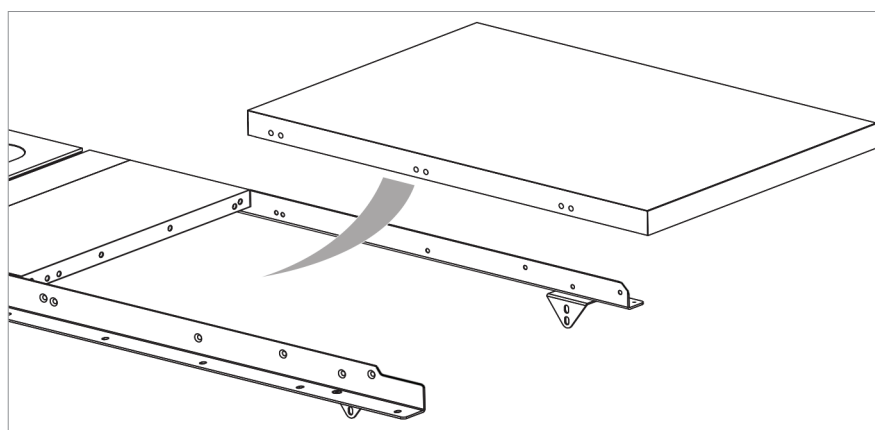

Fig. 19

Installing Your T-Glide Fence System

- The extension table mounts to the rails with bolts that pass through holes in the rails and extension table (See Fig. 20). If you have an extension table for a 36" fence system, take two M8 x 35 countersunk socket head bolts and insert one through the hole in the front rail closest to the saw and the other through the hole in the rear rail closest to the saw. If you have an extension table for a 52" fence system, take four M8 x 35 countersunk socket head bolts and insert one bolt into each of the two holes in the front rail closest to the saw, and one bolt into each of the two holes in the rear rail closest to the saw.

Place an M8 washer, an M8 lock washer, and an M8 hex nut on the threaded end of each bolt and hand tighten the nuts. Do not insert bolts through the outermost holes in the front and rear rails at this time.

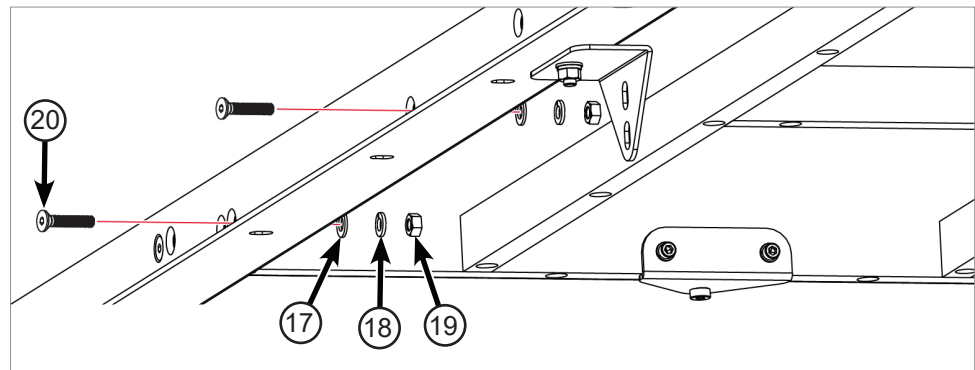

Fig. 20

- Locate the two support legs and remove the two feet from the T-Glide Table Hardware Pack along with two M8 hex nuts. Thread an M8 hex nut onto the threaded shaft of each foot so that the nut is close to the rubber base, and then thread the foot into the bottom of the support leg as far as possible (See Fig. 21).

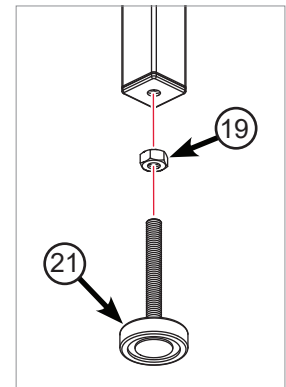

Fig. 21

- The support legs attach to the outer ends of the rails and extension table with M8 x 65 countersunk socket head bolts. Align the top hole in one support leg with the outermost hole in the front rail, and the top hole in the second support leg with the outermost hole in the back rail. Make sure the legs are positioned against the inside of the extension table. Insert an M8 x 65 bolt through the holes in the rails, extension table and legs. Place an M8 washer and an M8 lock washer on the threaded end of each bolt and then thread an M8 hex nut onto each bolt (See Fig. 22). Hand tighten the nuts; do not fully tighten them.

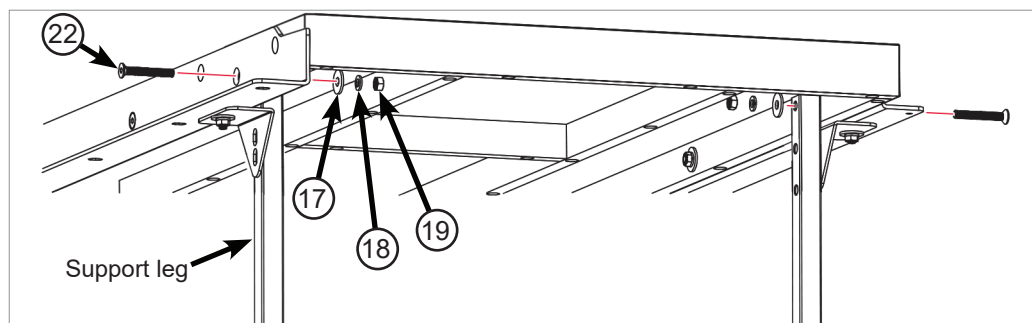

Fig. 22

Installing Your T-Glide Fence System

13. Attach each support leg to the corresponding leg support bracket with an M10 x 40 hex head bolt, two M10 washers, and an M10 lock nut, as shown in **Fig. 23**, and fully tighten the bolts using two 17 mm wrenches. Note that the leg support brackets align with different holes in the front and rear legs because the brackets are at different elevations.

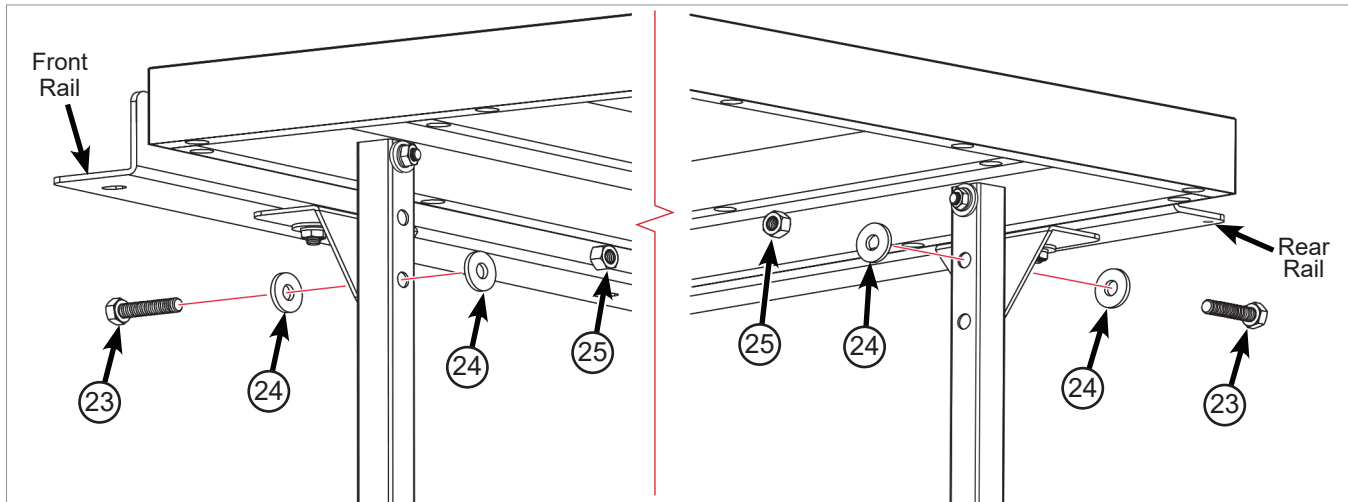

Fig. 23

14. Use a straight-edge to level the front edge of the extension table to the saw table (**See Fig. 24**). You may have to pull up or push down on the extension table to level it. Once the front edge of the extension table is level, use a 5 mm hex key and a 13 mm wrench to fully tighten the nuts on the bolts along the front rail. Repeat the process to level the rear edge of the extension table. Also fully tighten the bolts that attach the leg support brackets to the front and rear rails (bolts 16 in step 8).

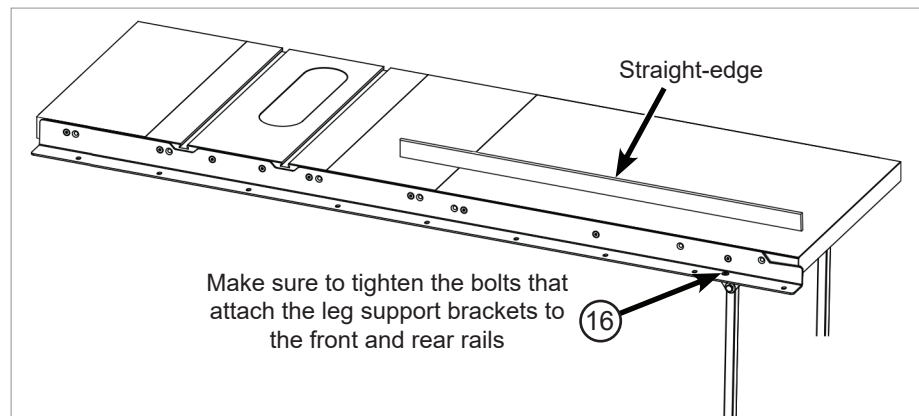

Fig. 24

Installing Your T-Glide Fence System

15. Place the straight-edge lengthwise across the middle of the table and level the middle of the extension table by turning the screw in the adjustment bracket with a 5 mm hex key (See Fig. 25).

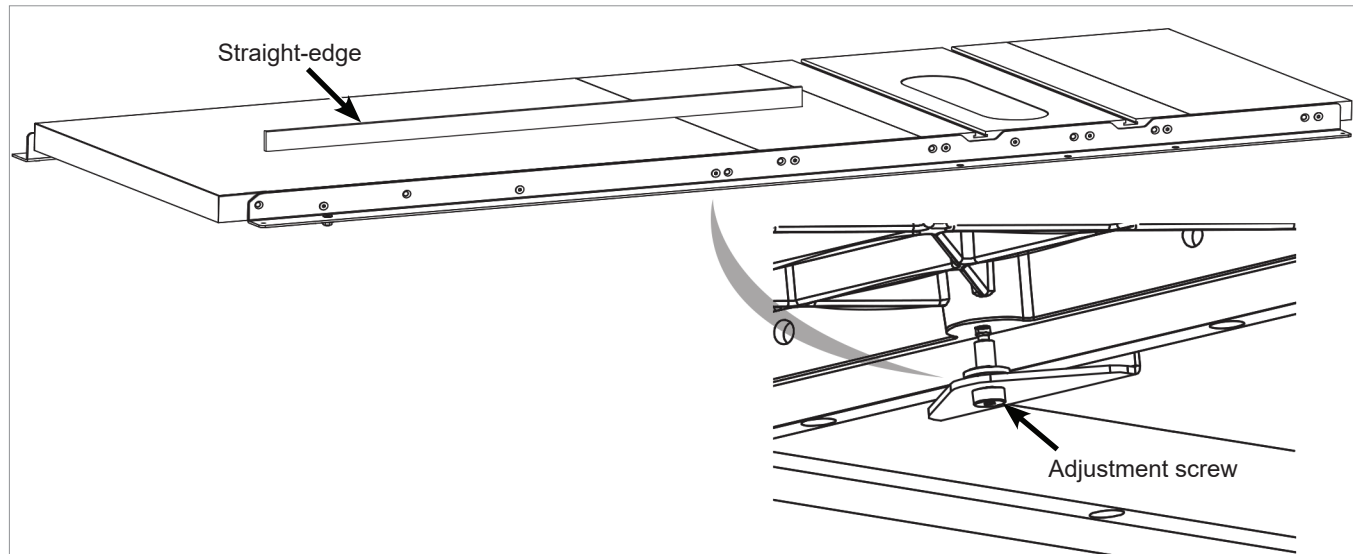

Fig. 25

NOTE: The adjustment bracket is designed for cast iron wings only. If you have a Contractor Saw with stamped wings, you may skip this step and go on to step 16.

16. Turn the foot on the bottom of each support leg to adjust its position until it is in solid contact with the ground. Once the foot is in contact with the ground, fully tighten the hex nut against the bottom of the leg using a 13 mm wrench (See Fig. 26).

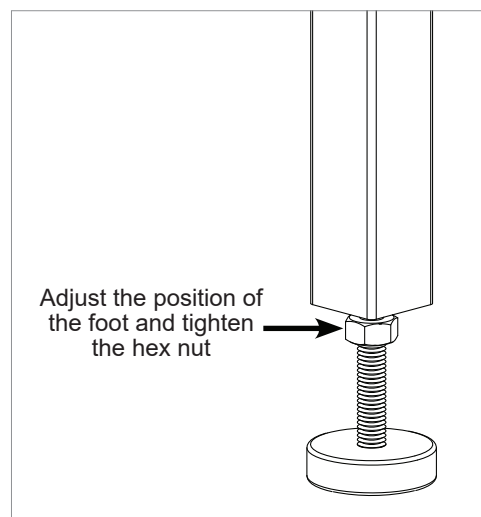

Fig. 26

Installing Your T-Glide Fence System

17. Locate the main tube and the T-Glide Rails Hardware Pack (See Fig. 27). If you have a 36" fence system, remove seven M8 x 16 hex head bolts and seven M8 lock washers from the T-Glide Rails Hardware Pack. If you have a 52" fence system, remove nine M8 x 16 hex head bolts and nine M8 lock washers from the T-Glide Rails Hardware Pack. Position the tube on the front rail with the rulers facing up and the 12-inch ruler on the left. The powder coated surfaces of the tube and rail can be slick, so be careful that the tube does not fall off the rail. Align the holes in the rail with the holes in the bottom of the tube. Place an M8 lock washer on each M8 x 16 hex head bolt and insert the bolts through the rail and into the threaded holes in the bottom of the tube (See Fig. 28). Hand tighten the bolts; do not fully tighten them.

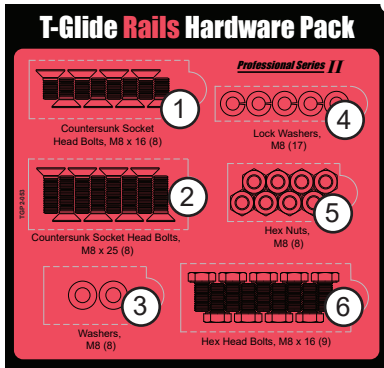

Fig. 27

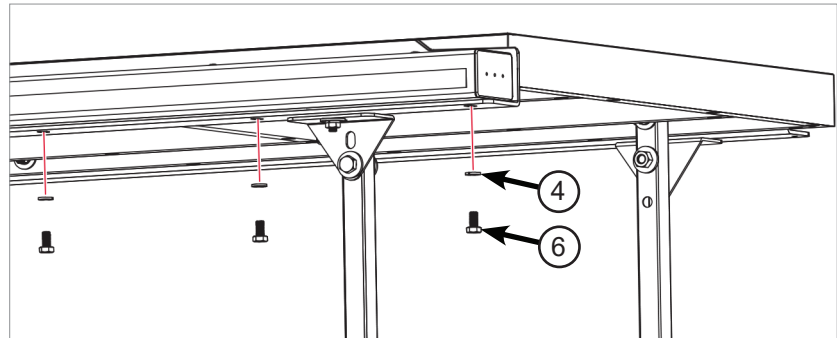

Fig. 28

18. Locate the fence and the red fence handle. Thread the handle into the cam lock on the front of the fence (See Fig. 29).

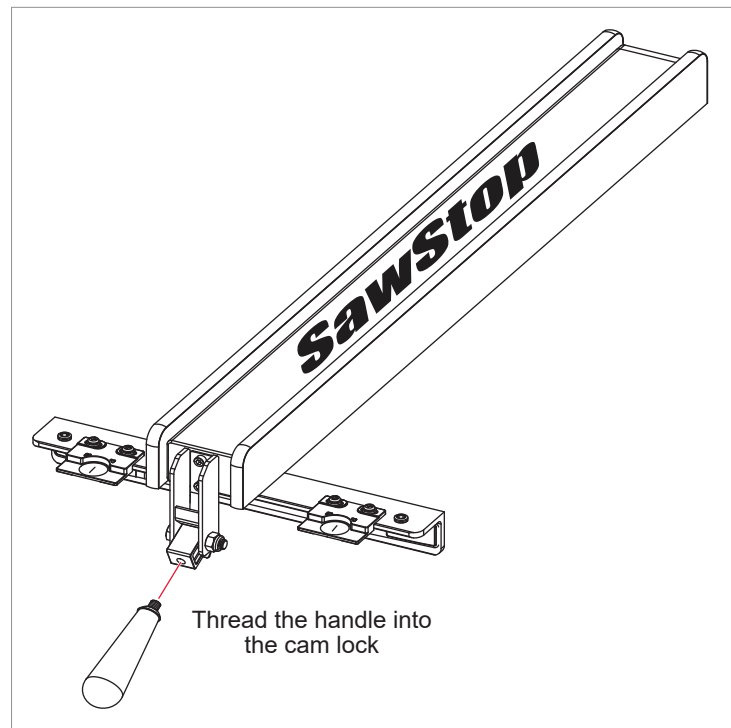

Fig. 29

Installing Your T-Glide Fence System

19. The holes in the bottom of the front rail are oversized to allow you to adjust the position of the tube on the rail. To set the tube in the correct position, first pull the front tube away from the table as far as possible. Next, place your fence down on the tube near the left end (See Fig. 30).

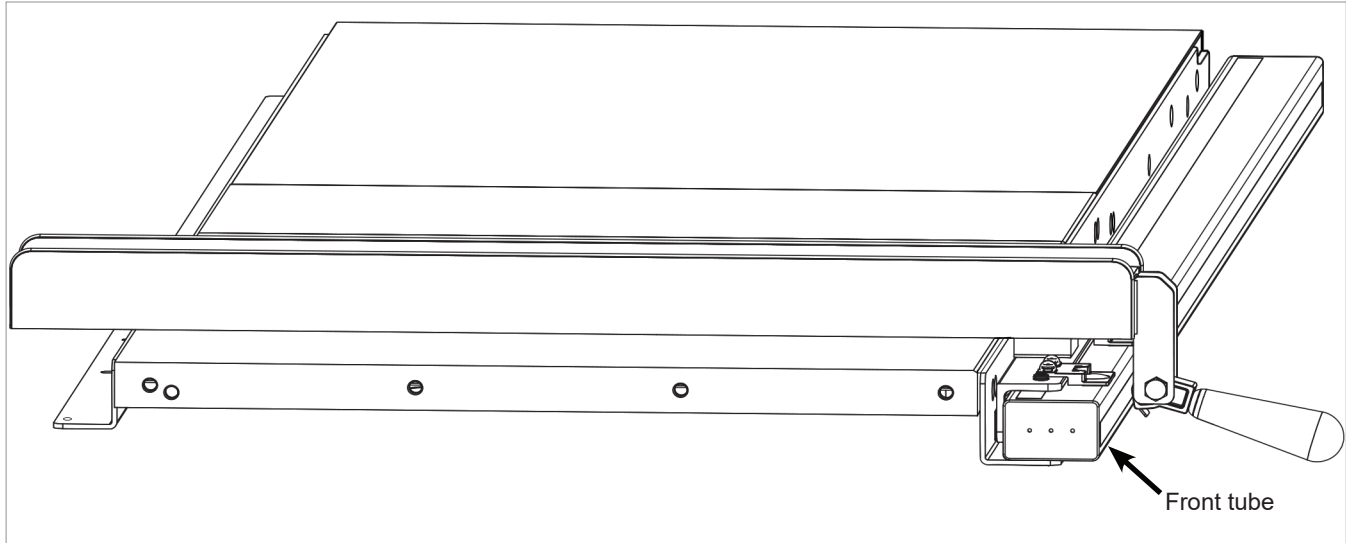

Fig. 30

20. Press down on the fence handle to clamp the fence to the front tube. If the fence does not clamp tightly enough to hold its position against a moderate amount of force, you can increase the clamping pressure by turning both parallelism adjustment screws clockwise using a 5 mm hex key. Those screws are located in the vertical portion of the fence cross-bracket (See Fig. 31). Alternatively, if too much force is required to push the fence handle down to clamp the fence to the front tube, you can reduce the clamping pressure by turning both parallelism adjustment screws counter-clockwise.

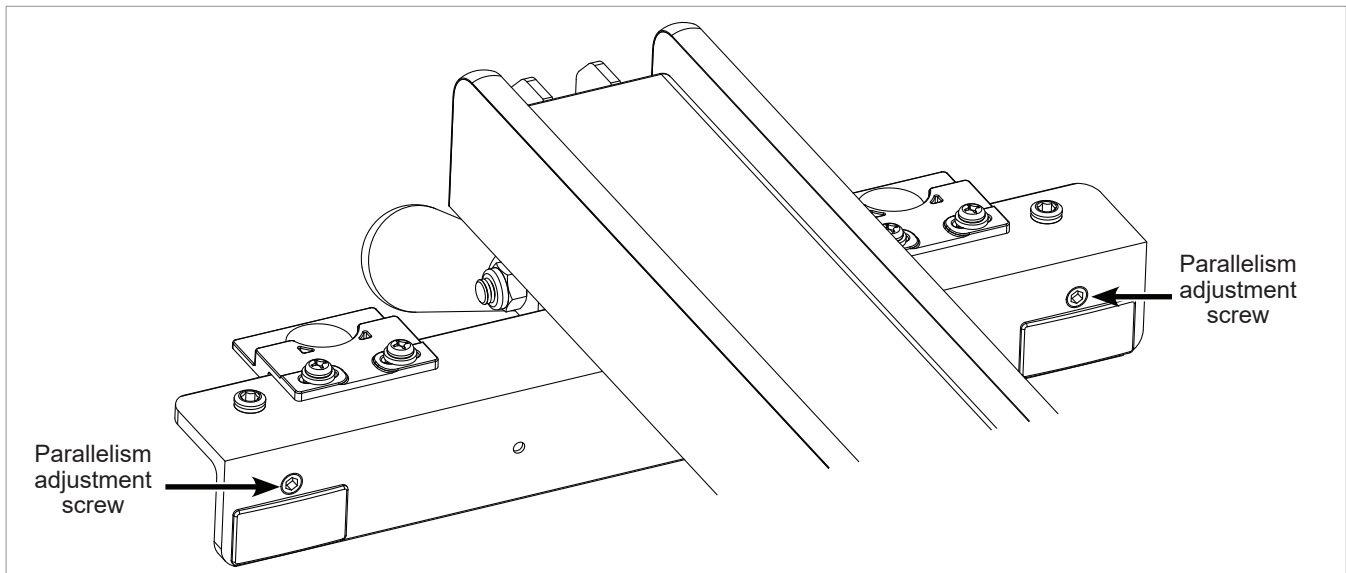

Fig. 31

Installing Your T-Glide Fence System

21. Once the fence is tightly clamped to the front tube, move the left end of the tube back toward the saw until there is only a small gap (approximately 1/32 inch) between the front rail and the rear of the fence (See Fig. 32). Tighten the left-most M8 x 16 hex head bolt that holds the tube to the front rail using a 13 mm wrench.

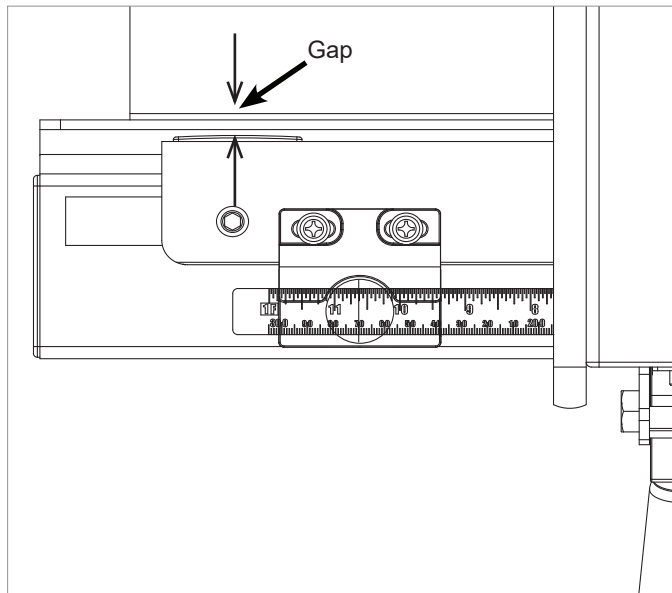

Fig. 32

22. Next, move the fence to the right end of the tube, repeat the above process to position the tube, and tighten the right-most screw (See Fig. 33). Once both ends of the tube are adjusted correctly, tighten the remaining M8 x 16 hex head bolts to mount the front tube to the front rail. The fence should now slide smoothly along the front tube without binding and without excessive play.

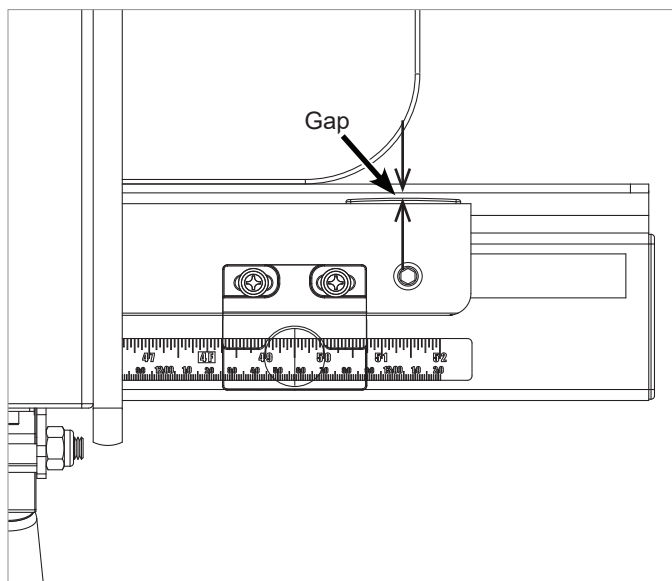

Fig. 33

Adjusting Your T-Glide Fence System

Although the fence is factory-adjusted to nominal settings, it is usually necessary to make final adjustments once your rails and extension table have been installed on the saw.

The fence allows you to precisely set the width of your rip cuts (cuts that are length-wise along the grain of the wood). The precise width of cut is shown by the indicator lenses on the front of the fence (See Fig. 34). The lens on the left indicates the width of cut when the fence is on the left side of the blade. The lens on the right indicates the width of cut when the fence is on the right side of the blade. Each indicator lens is positioned above a ruler on the front tube. Each lens has a red cursor line that indicates the precise width of cut. To read the width of cut, look down at the cursor line. The mark on the ruler that is directly below the cursor line is the width of cut.

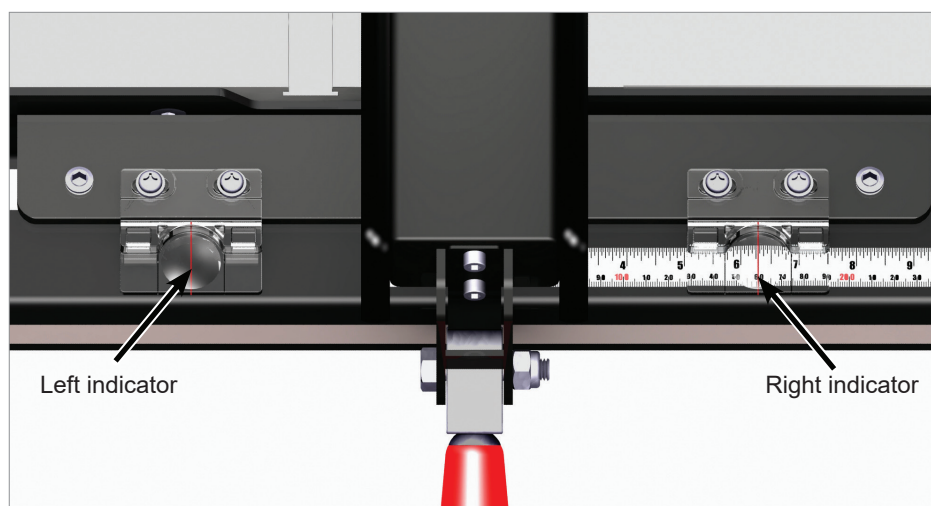

Fig. 34

If necessary, you can adjust the position of the indicator lenses on the front of the fence. To verify the position of each indicator lens, clamp the fence to the front tube and use a ruler to measure the distance from the blade to the fence plate and compare it to the measurement shown on the proper indicator lens. If adjustment is necessary, loosen the two Phillips screws shown in Fig. 35 and slide the indicator lens to the right or left until the cursor is directly over the correct measurement. Tighten the screws to lock the position of the indicator lens.

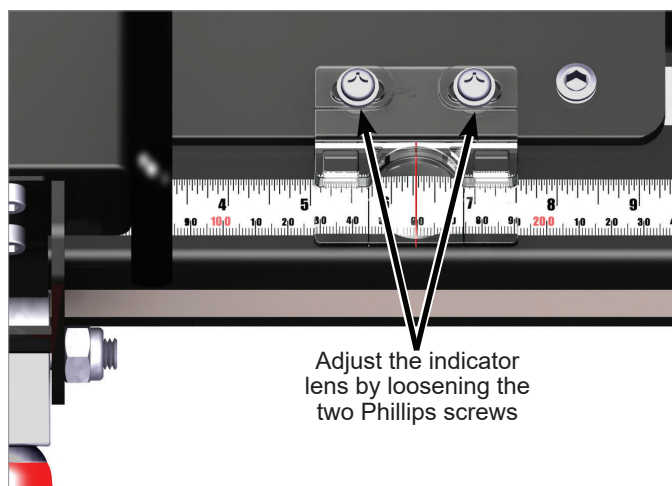

Fig. 35

Adjusting Your T-Glide Fence System

The next step is to align the face plates to be parallel to the miter slots. Begin by sliding the fence along the front tube until the left face plate is flush with the right edge of the right miter slot. Lock the fence handle and check that the face plate is flush with the miter slot edge along its whole length (See Fig. 36). You can check this either visually or by running your finger along the face plate and miter slot edge. If there is any misalignment, you can correct it by turning one of the two parallelism adjustment screws in the vertical edge of the fence cross-bracket (See Fig. 31).



Fig. 36

The next step is to adjust the face plates to be perpendicular to the table top. The angle between the face plates and the table is set by the two plastic leveling screws in the horizontal portion of the cross-bracket (See Fig. 37). The leveling screws raise and lower each end of the horizontal portion of the fence cross-bracket with respect to the main tube while the two face plates remain parallel with each other. Adjusting the leveling screws tilts the fence cross-bracket as needed to make the face plates perpendicular to the table.



Fig. 37

To adjust the angle of the face plates, place a combination square on the table top and against the left face plate (See Fig. 38). Use a 6 mm hex key to adjust the leveling screws as necessary until the face plate is parallel to the vertical edge of the combination square.

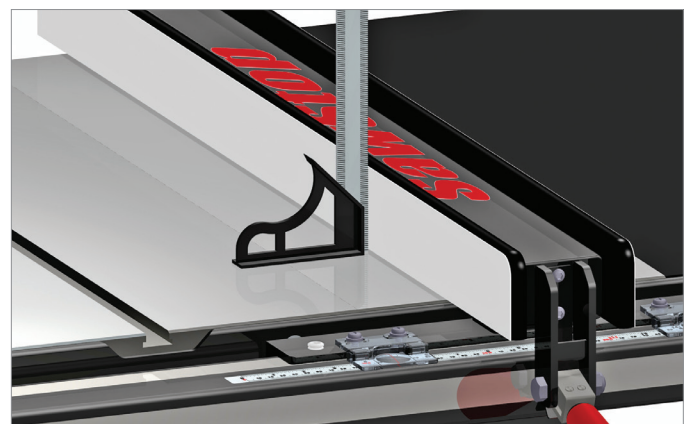
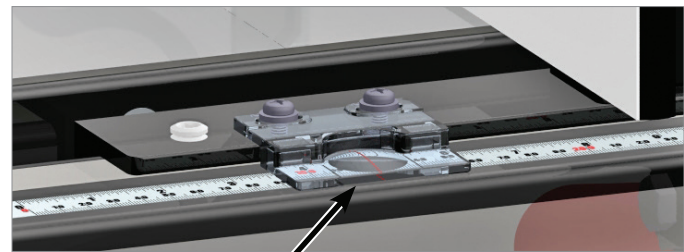

Fig. 38

Adjusting Your T-Glide Fence System

You may find that after adjusting the face plates the end of the cross-bracket has been raised or lowered such that it is too close or too far away from the main tube. If this is the case, turn both plastic leveling screws the same amount in order to ensure the position indicator lenses are close to, but not touching, the front tube or rulers (See Fig. 44).



There should be a gap between the position indicator lens and the ruler on the main tube.

Fig. 44

The last step is to set the spacing between the bottom of each face plate and the table. The face plates are held in place by a series of screws threaded into nuts embedded in the face plates. The heads of the screws fit into key-hole slots in the sides of the fence (See Fig. 40 with endcap removed).

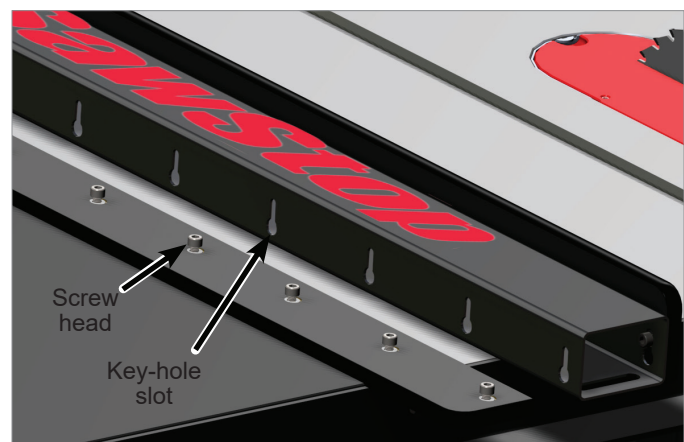

Fig. 40

It is usually possible to adjust the position of the face plates by placing a small block of wood against the top or bottom edge of the face plates, and then tapping the block of wood with a plastic or wooden mallet. However, if the face plates do not move when tapped, you can loosen the mounting screws as described below to adjust the face plates.

You can access the screws that attach the face plates to the fence through the slots on the bottom of the fence. Insert a 5 mm ball-end hex driver through the slot at the end of the fence and into the screw head (See Fig. 41) with endcap removed). Loosen the screw about one-quarter to one-half turn. Do not loosen the screw too much. The screw should be just loose enough to allow the plate to move but still tight enough to hold the plate temporarily in its new position. Continue this process with each slot/screw pair. Once all the screws on one face plate are loose, slide the face plate toward the top of the fence.

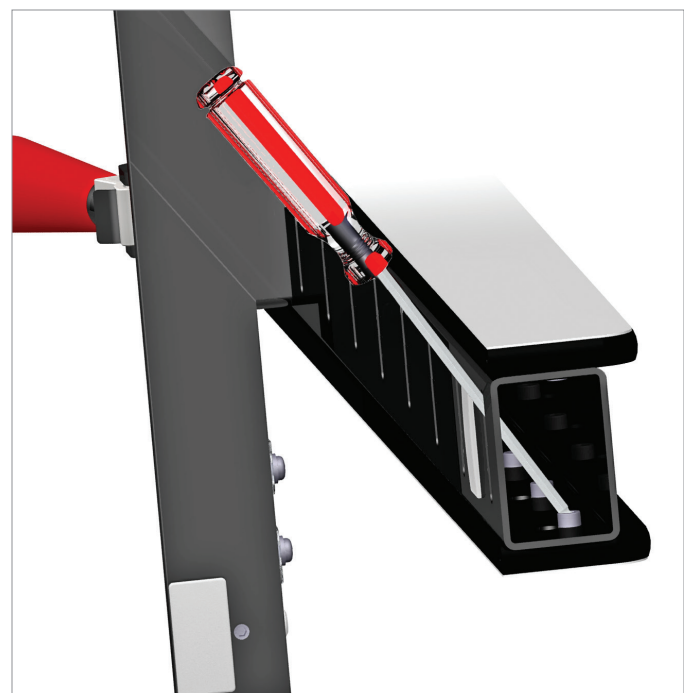

Fig. 41

Adjusting Your T-Glide Fence System

Install the fence on the front tube and position the face plate as desired, making sure to leave at least a small gap between the bottom of the face plate and the table so the face plate does not drag on the table. It may be necessary to loosen and raise the other face plate as well if it is too low and interferes with the adjustment.

Next, carefully lift the fence off the front tube and place it on the table with the newly adjusted face plate facing down. Make sure not to move the face plate from the position you set. If necessary you can clamp the face plate to the fence to keep the face plate from moving. Tighten each screw to lock the face plate in position. Make sure not to over-tighten these screws as that may cause a slight concavity in the surface of the face plate near the screw.

Now adjust the position of the other face plate if necessary.

Congratulations, your fence system is now installed and your saw is ready to use.

Using Your T-Glide Fence System

The rip fence included with your T-Glide Fence System is used to guide material parallel to the blade when you make rip cuts (cuts that are length-wise along the grain of the wood). The fence must always be used when making rip cuts.

To use the rip fence, begin by placing it on the table so that the fence bracket is resting on the upper rear edge of the front tube. You can use the fence on either the left or right side of the blade for non-bevel cuts. If you plan to make bevel cuts, use the fence only on the right side to prevent the blade from possibly contacting the fence. After placing the fence on the rails, lift the red handle up to the unlocked position and slide the fence to the left or right until the distance between the blade and the fence is approximately equal to the desired width of cut. Adjust the position of the fence until the cursor on the indicator lens is directly over the desired width of the cut. Use the lens on the left when the fence is on the left side of the blade and use the lens on the right when the fence is on the right side of the blade. Once the fence is in the correct position, push the red locking handle down to the locked position (See Fig. 42). The fence is now locked in place and ready for use.



Fig. 42

T-Glide Fence Exploded View

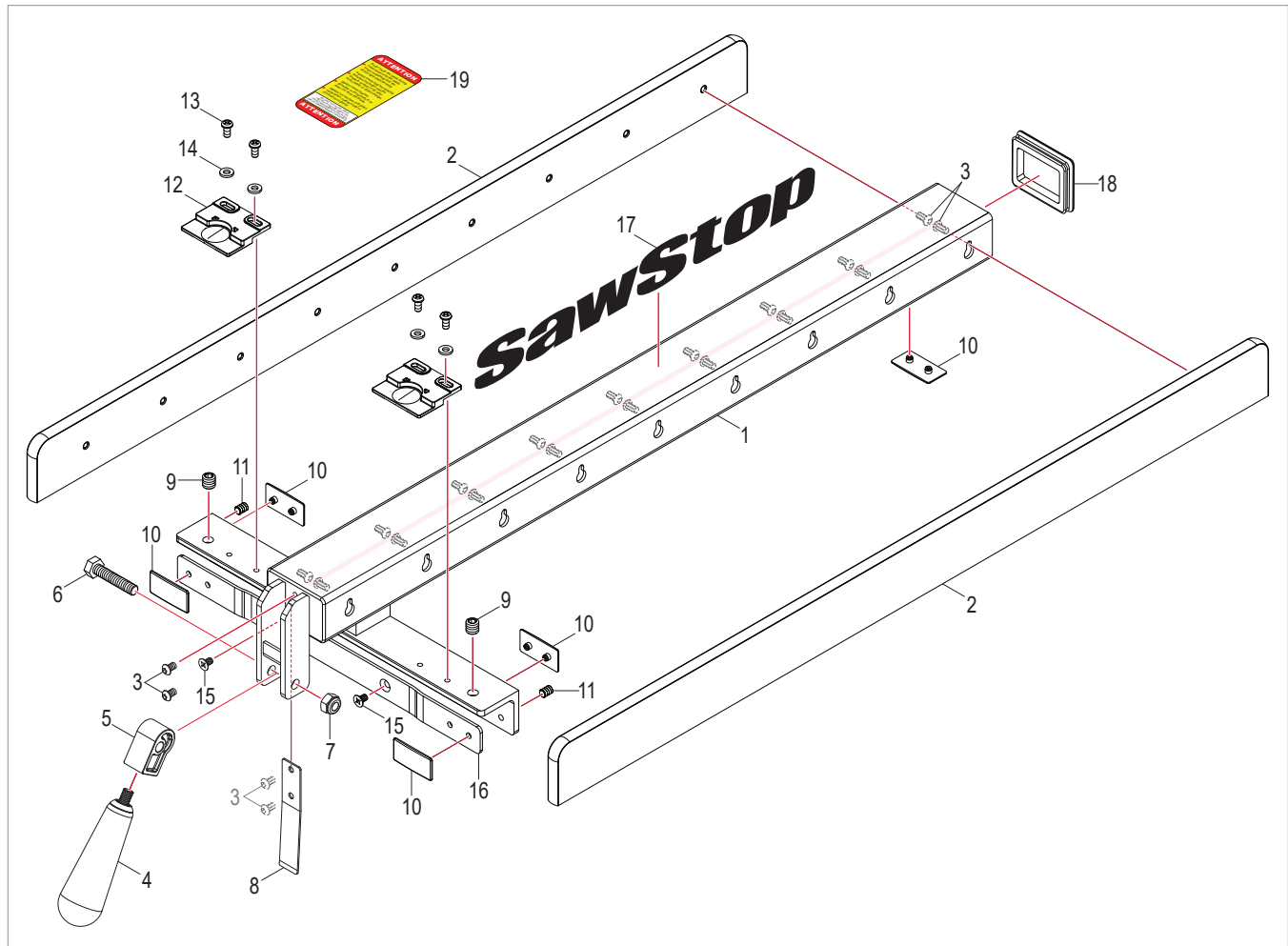

Fig. 43

T-Glide Fence Parts List

No.	Description	Part No.	Qty.
	Professional Series II T-Glide Fence Assembly (items 1-18)	TGP2-FA	1
1	Fence Tube	TGP2-001	1
2	Face Plate	TGP2-002	2
3	M6x1.0x10 Socket Head Screw	TGP2-003	20
4	Handle	TGP2-004	1
5	Cam Lock	TGP2-005	1
6	M10x1.5x45 Hex Head Bolt	TGP2-006	1
7	M10x1.5 Lock Nut	TGP2-007	1
8	Flex Plate	TGP2-008	1
9	Leveling Adjustment Screw M12x1.75	TGP2-009	2
10	Glide Plate	TGP2-010	5
11	M10x1.5x10 Set Screw	TGP2-011	2
12	Position Indicator Lens	TGP2-012	2
13	M6x1.0x10 Pan Head Phillips Screw	TGP2-013	4
14	M6x13x1.5 Washer	TGP2-014	4
15	M6x1.0x8 Flat Head Phillips Screw	TGP2-015	2
16	Flex Arm	TGP2-016	1
17	SawStop Label	TGP2-017	1
18	Fence Endcap	TGP2-018	1
19	Fence Attention Magnet	TGP2-075	1
	Accessories		
N/A	5 mm Ball-end Hex Driver	TGP2-019	1
N/A	6 mm Hex Key	TGP2-020	1

36" Fence System Rails and Extension Table Exploded View for a Cabinet Saw

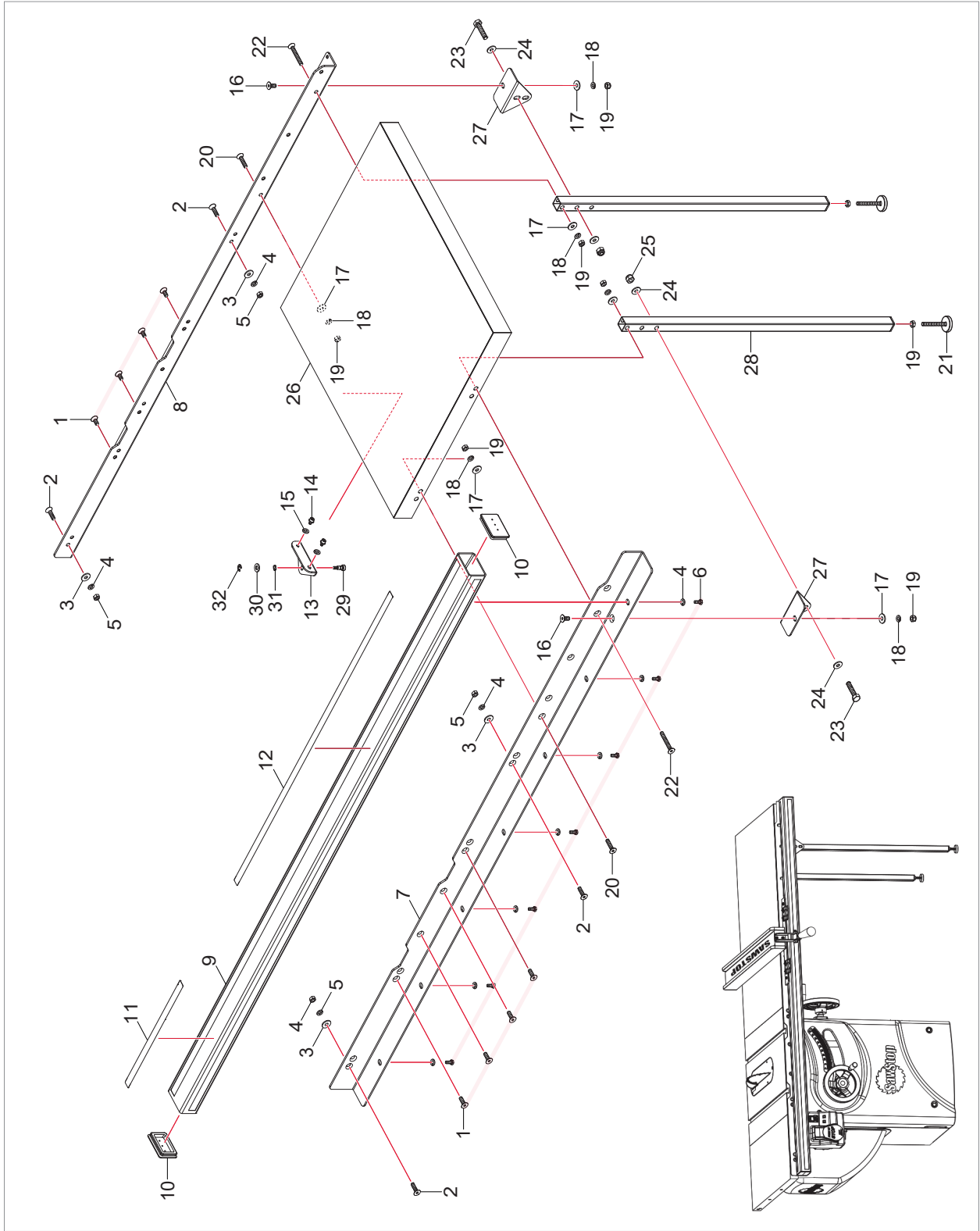
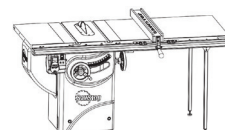

Fig. 44

36" Fence System Rails and Extension Table **Parts List for a Cabinet Saw**



No.	Description	Part No.	Qty.
	Professional Series II 36" T-Glide Fence Rails (items 1-12)	TGP2-R36A	1
1	M8x1.25x16 Countersunk Socket Head Bolt	TGP2-021	8
2	M8x1.25x25 Countersunk Socket Head Bolt	TGP2-022	4
3	M8x23x2 Washer	TGP2-023	4
4	M8 Lock Washer	TGP2-024	11
5	M8x1.25 Hex Nut	TGP2-025	4
6	M8x1.25x16 Hex Head Bolt	TGP2-026	7
7	36" Front Rail	TGP2-027	1
8	36" Rear Rail	TGP2-028	1
9	36" Main Tube	TGP2-029	1
10	Main Tube End Cap	TGP2-030	2
11	12" Ruler	TGP2-031	1
12	36" Ruler	TGP2-032	1
	Professional Series II 36" T-Glide Extension Table (items 13-32)	TGP2-T36A	1
13	Adjustment bracket	TGP2-033	1
14	M6x1.0x18 Socket Cap Screw	TGP2-034	2
15	M6 Lock Washer	TGP2-035	2
16	M8x1.25x20 Countersunk Socket Head Bolt	TGP2-036	2
17	M8x23x2 Washer	TGP2-037	6
18	M8 Lock Washer	TGP2-038	6
19	M8x1.25 Hex Nut	TGP2-039	8
20	M8x1.25x35 Countersunk Socket Head Bolt	TGP2-040	2
21	Foot	TGP2-041	2
22	M8x1.25x65 Countersunk Socket Head Bolt	TGP2-042	2
23	M10x1.5x40 Hex Head Bolt	TGP2-043	2
24	M10x25x1.5 Washer	TGP2-044	4
25	M10x1.5 Lock Nut	TGP2-045	2
26	36" Table	TGP2-046	1
27	Leg Support Bracket	TGP2-047	2
28	Support Leg	TGP2-048	2
29	Adjustment Screw	TGP2-049	1
30	M9x18.3x2.3 Washer	TGP2-050	1
31	M9 Wave Washer	TGP2-051	1
32	M8 Retaining Ring	TGP2-052	1
	Accessories		
N/A	T-Glide Rails Hardware Pack	TGP2-053	1
N/A	T-Glide Table Hardware Pack	TGP2-054	1
N/A	Professional Cabinet Saw Fence System Installation Poster	TGP2-055	1
N/A	T-Glide Fence System Professional Series II Owner's Manual	TGP2-056	1

52" Fence System Rails and Extension Table Exploded View for a Cabinet Saw

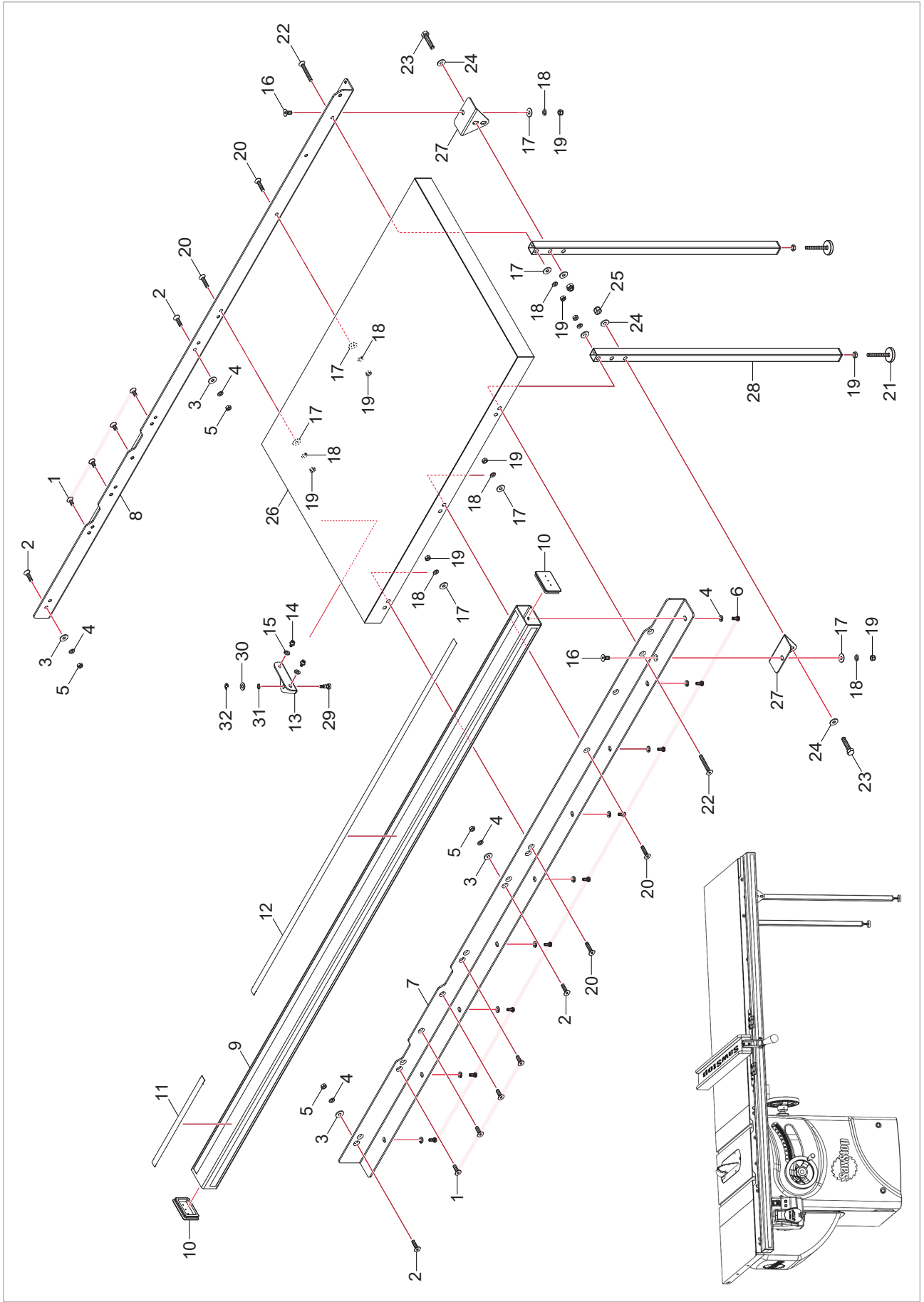
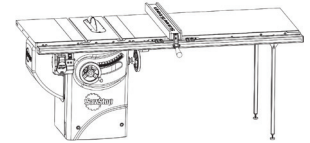

Fig. 45

52" Fence System Rails and Extension Table **Parts List for a Cabinet Saw**



No.	Description	Part No.	Qty.
	Professional Series II 52" T-Glide Fence Rails (items 1-12)	TGP2-R52A	1
1	M8x1.25x16 Countersunk Socket Head Bolt	TGP2-021	8
2	M8x1.25x25 Countersunk Socket Head Bolt	TGP2-022	4
3	M8x23x2 Washer	TGP2-023	4
4	M8 Lock Washer	TGP2-024	13
5	M8x1.25 Hex Nut	TGP2-025	4
6	M8x1.25x16 Hex Head Bolt	TGP2-026	9
7	52" Front Rail	TGP2-057	1
8	52" Rear Rail	TGP2-058	1
9	52" Main Tube	TGP2-059	1
10	Main Tube Endcap	TGP2-030	2
11	12" Ruler	TGP2-031	1
12	52" Ruler	TGP2-060	1
	Professional Series II 52" T-Glide Extension Table (items 13-32)	TGP2-T52A	1
13	Adjustment bracket	TGP2-033	1
14	M6x1.0x18 Socket Cap Screw	TGP2-034	2
15	M6 Lock Washer	TGP2-035	2
16	M8x1.25x20 Countersunk Socket Head Bolt	TGP2-036	2
17	M8x23x2 Washer	TGP2-037	8
18	M8 Lock Washer	TGP2-038	8
19	M8x1.25 Hex Nut	TGP2-039	10
20	M8x1.25x35 Countersunk Socket Head Bolt	TGP2-040	4
21	Foot	TGP2-041	2
22	M8x1.25x65 Countersunk Socket Head Bolt	TGP2-042	2
23	M10x1.5x40 Hex Head Bolt	TGP2-043	2
24	M10x25x1.5 Washer	TGP2-044	4
25	M10x1.5 Lock Nut	TGP2-045	2
26	52" Table	TGP2-061	1
27	Leg Support Bracket	TGP2-047	2
28	Support Leg	TGP2-048	2
29	Adjustment Screw	TGP2-049	1
30	M9x18.3x2.3 Washer	TGP2-050	1
31	M9 Wave Washer	TGP2-051	1
32	M8 Retaining Ring	TGP2-052	1
	Accessories		
N/A	T-Glide Rails Hardware Pack	TGP2-053	1
N/A	T-Glide Table Hardware Pack	TGP2-054	1
N/A	Professional Cabinet Saw Fence System Installation Poster	TGP2-055	1
N/A	T-Glide Fence System Professional Series II Owner's Manual	TGP2-056	1

36" Fence System Rails and Extension Table Exploded View for a Contractor Saw

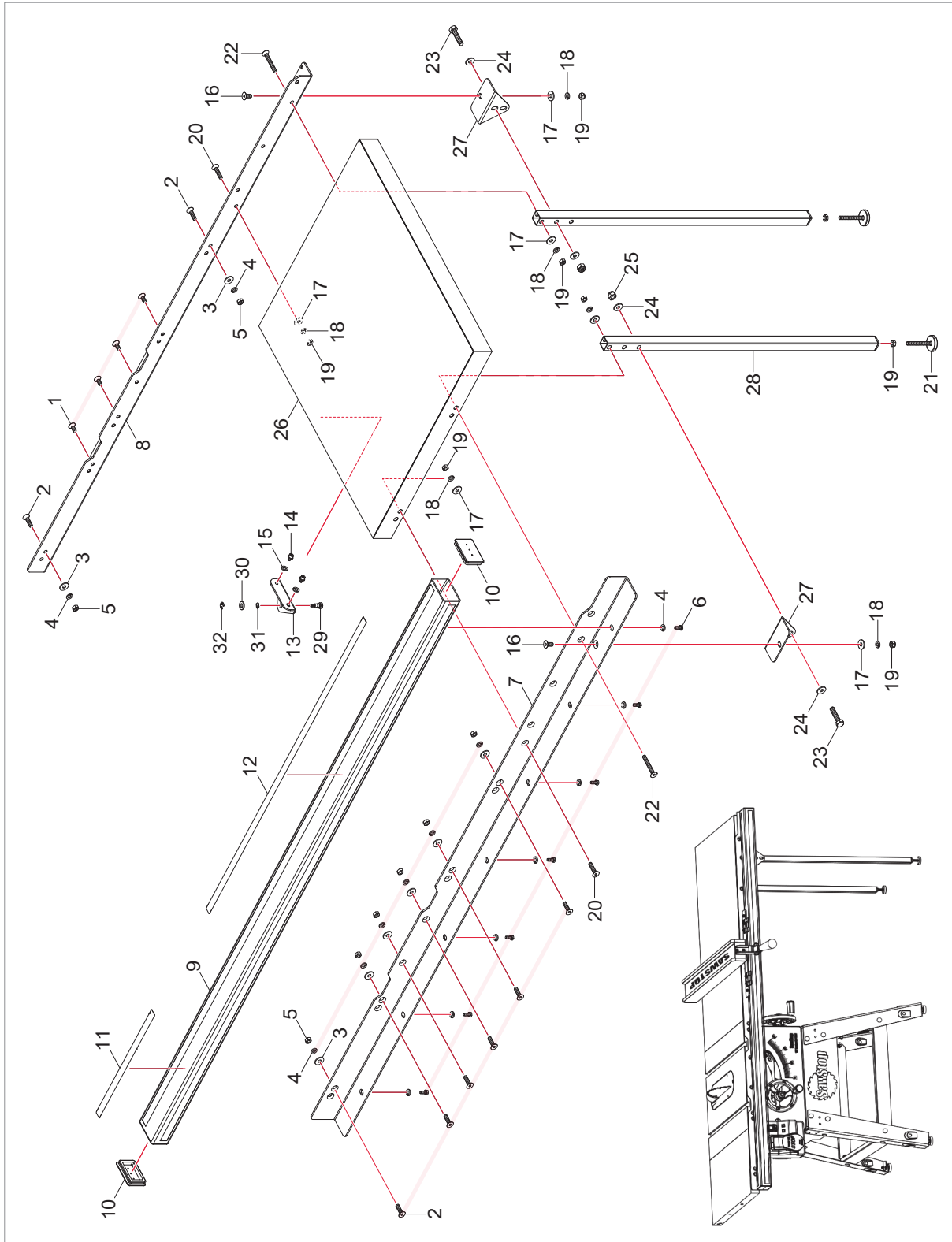
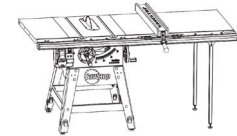

Fig. 46

36" Fence System Rails and Extension Table **Parts List for a Contractor Saw**



No.	Description	Part No.	Qty.
	Professional Series II 36" T-Glide Fence Rails (items 1-12)	TGP2-R36A	1
1	M8x1.25x16 Countersunk Socket Head Bolt	TGP2-021	4
2	M8x1.25x25 Countersunk Socket Head Bolt	TGP2-022	8
3	M8x23x2 Washer	TGP2-023	8
4	M8 Lock Washer	TGP2-024	15
5	M8x1.25 Hex Nut	TGP2-025	8
6	M8x1.25x16 Hex Head Bolt	TGP2-026	7
7	36" Front Rail	TGP2-027	1
8	36" Rear Rail	TGP2-028	1
9	36" Main Tube	TGP2-029	1
10	Main Tube Endcap	TGP2-030	2
11	12" Ruler	TGP2-031	1
12	36" Ruler	TGP2-032	1
	Professional Series II 36" T-Glide Extension Table (items 13-32)	TGP2-T36A	1
13	Adjustment bracket	TGP2-033	1
14	M6x1.0x18 Socket Cap Screw	TGP2-034	2
15	M6 Lock Washer	TGP2-035	2
16	M8x1.25x20 Countersunk Socket Head Bolt	TGP2-036	2
17	M8x23x2 Washer	TGP2-037	6
18	M8 Lock Washer	TGP2-038	6
19	M8x1.25 Hex Nut	TGP2-039	8
20	M8x1.25x35 Countersunk Socket Head Bolt	TGP2-040	2
21	Foot	TGP2-041	2
22	M8x1.25x65 Countersunk Socket Head Bolt	TGP2-042	2
23	M10x1.5x40 Hex Head Bolt	TGP2-043	2
24	M10x25x1.5 Washer	TGP2-044	4
25	M10x1.5 Lock Nut	TGP2-045	2
26	36" Table	TGP2-046	1
27	Leg Support Bracket	TGP2-047	2
28	Support Leg	TGP2-048	2
29	Adjustment Screw	TGP2-049	1
30	M9x18.3x2.3 Washer	TGP2-050	1
31	M9 Wave Washer	TGP2-051	1
32	M8 Retaining Ring	TGP2-052	1
	Accessories		
N/A	T-Glide Rails Hardware Pack	TGP2-053	1
N/A	T-Glide Table Hardware Pack	TGP2-054	1
N/A	Contractor Saw Fence System Installation Poster	TGP2-062	1
N/A	T-Glide Fence System Professional Series II Owner's Manual	TGP2-056	1

52" Fence System Rails and Extension Table Exploded View for a Contractor Saw

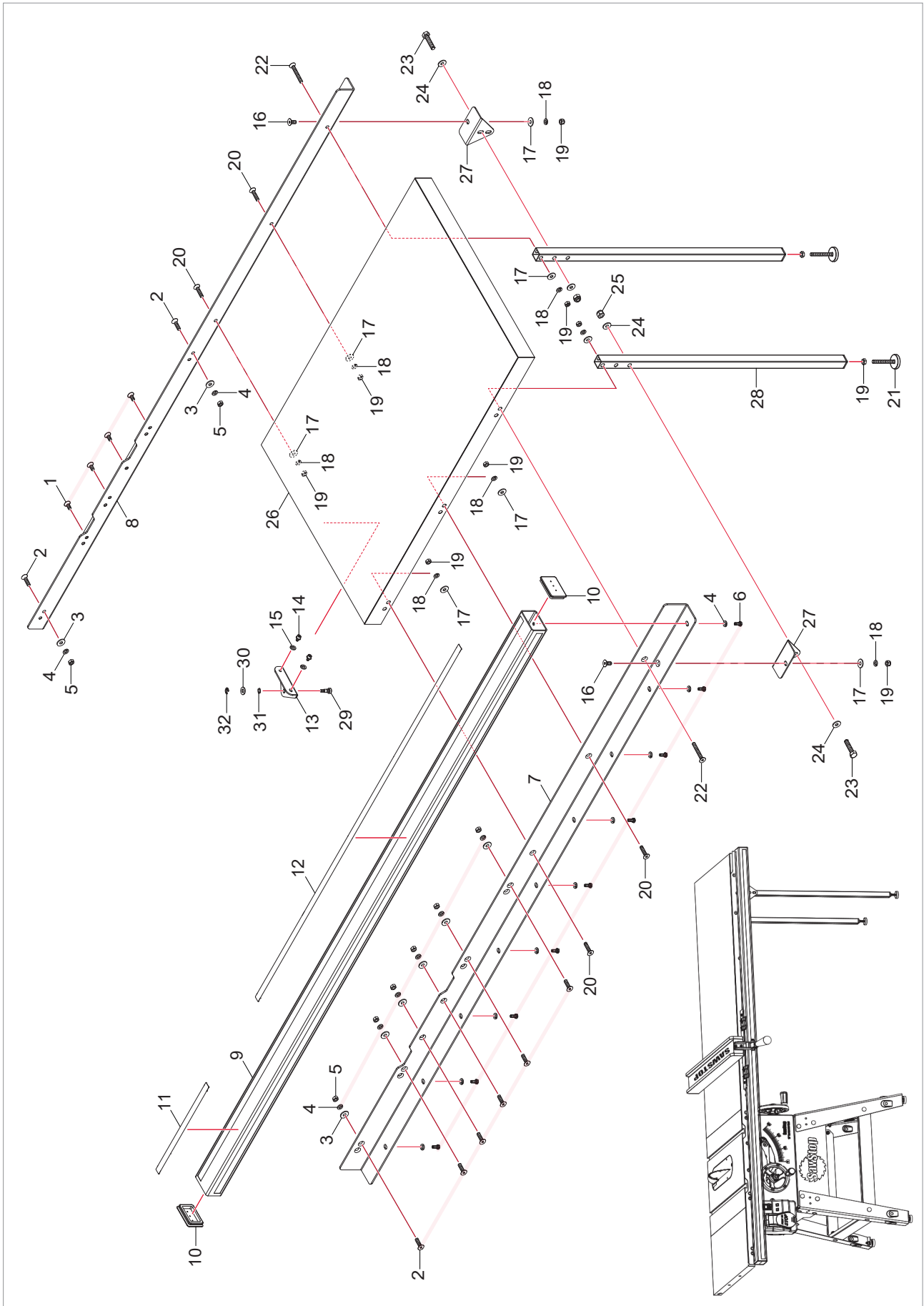
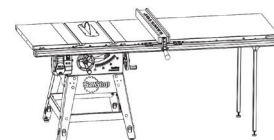

Fig. 47

52" Fence System Rails and Extension Table **Parts List for a Contractor Saw**



No.	Description	Part No.	Qty.
	Professional Series II 52" T-Glide Fence Rails (items 1-12)	TGP2-R52A	1
1	M8x1.25x16 Countersunk Socket Head Bolt	TGP2-021	4
2	M8x1.25x25 Countersunk Socket Head Bolt	TGP2-022	8
3	M8x23x2 Washer	TGP2-023	8
4	M8 Lock Washer	TGP2-024	17
5	M8x1.25 Hex Nut	TGP2-025	8
6	M8x1.25x16 Hex Head Bolt	TGP2-026	9
7	52" Front Rail	TGP2-057	1
8	52" Rear Rail	TGP2-058	1
9	52" Main Tube	TGP2-059	1
10	Main Tube Endcap	TGP2-030	2
11	12" Ruler	TGP2-031	1
12	52" Ruler	TGP2-060	1
	Professional Series II 52" T-Glide Extension Table (items 13-32)	TGP2-T52A	1
13	Adjustment bracket	TGP2-033	1
14	M6x1.0x18 Socket Cap Screw	TGP2-034	2
15	M6 Lock Washer	TGP2-035	2
16	M8x1.25x20 Countersunk Socket Head Bolt	TGP2-036	2
17	M8x23x2 Washer	TGP2-037	8
18	M8 Lock Washer	TGP2-038	8
19	M8x1.25 Hex Nut	TGP2-039	10
20	M8x1.25x35 Countersunk Socket Head Bolt	TGP2-040	4
21	Foot	TGP2-041	2
22	M8x1.25x65 Countersunk Socket Head Bolt	TGP2-042	2
23	M10x1.5x40 Hex Head Bolt	TGP2-043	2
24	M10x25x1.5 Washer	TGP2-044	4
25	M10x1.5 Lock Nut	TGP2-045	2
26	52" Table	TGP2-061	1
27	Leg Support Bracket	TGP2-047	2
28	Support Leg	TGP2-048	2
29	Adjustment Screw	TGP2-049	1
30	M9x18.3x2.3 Washer	TGP2-050	1
31	M9 Wave Washer	TGP2-051	1
32	M8 Retaining Ring	TGP2-052	1
	Accessories		
N/A	T-Glide Rails Hardware Pack	TGP2-053	1
N/A	T-Glide Table Hardware Pack	TGP2-054	1
N/A	Contractor Saw Fence System Installation Poster	TGP2-062	1
N/A	T-Glide Fence System Professional Series II Owner's Manual	TGP2-056	1

SawStop, LLC
11555 S.W. Myslony Street
Tualatin, Oregon 97062
www.sawstop.com

Main Phone - (503) 570-3200
Service - (503) 582-9934
Fax - (503) 570-3303
Email: info@sawstop.com

Updates of this manual may be available at www.sawstop.com.

Patents Pending. Copyright SawStop, LLC. All Rights Reserved.
SawStop is a registered trademark and T-Glide is a trademark of SawStop, LLC.

M PCS 18 0010 00
January 2020