

SawStop[®]

10" CONTRACTOR SAW

CNS[™]

OWNER'S MANUAL

Models CNS175, CNS175-AU



Copyright SawStop, LLC
All Rights Reserved.

Revised June 2024

Updates to this manual and additional related
documentation such as exploded views and parts
lists are available at SawStop.com

The saw on the front cover is shown with fence
model CNS-PFA30. Your saw may look different.

SawStop, the SawStop blade logo, and the configuration of this product are either registered trademarks or trademarks of SawStop, LLC. Software copyright by SawStop, LLC. All rights reserved. Protected by the following U.S. patents: 7098800, 7350445, 7472634, 7481140, 7536238, 7707918, 7707920, 7827890, 7971613, 7991503, 7997176, 8061245, 8087438, 8266997, 8459157, 8469067, 8489223, 8505424, 9623498, 9724840, 10052786, 10442108, 10589366, 10882207, 10967536, 11027452.

TO OUR CUSTOMERS

Thank you for purchasing a SawStop® Contractor Saw! Your saw includes our revolutionary, award-winning safety system that tells the difference between cutting wood and cutting a person. If you ever accidentally contact the moving blade, the safety system will detect that contact and stop the blade in milliseconds to minimize any injury.

This manual tells you more about your Contractor Saw and how to operate and maintain it. Please read the manual carefully. The manual also includes our warranty and important safety information.

Again, thanks for purchasing a SawStop® Contractor Saw. We are confident you will be pleased with its performance. If you ever have any questions or comments, feel free to contact us at the address below.

SawStop, LLC
11555 SW Myslony Street
Tualatin, Oregon 97062 USA
SawStop.com

Technical Support	503-582-9934	service@sawstop.com
Parts Store	503-486-6923	parts@sawstop.com
Sales / Customer Service	503-595-2665	sales@sawstop.com

TABLE OF CONTENTS

Warranty	5
No Warranty of Safety	5
If You Have an Accident	5
Safety	6
Warnings	6
Warning Labels	10
The SawStop® Safety System	11
Unpacking Your Saw	14
Assembling Your Saw	16
Assembling the Stand	16
Mounting the Saw to the Stand	19
Installing the Elevation Hand-wheel	22
Installing the Tilt Hand-wheel	22
Installing the Motor and Belt Guard	23
Mounting the Extension Wings	24
Mounting the Switch Box	25
Get to Know Your Saw	26
Preparing Your Saw for Use	28
Saw Placement	28
Table Insert Removal and Installation	28
Blade or Dado Installation	29
Brake Position Adjustment	30
Blade Guard and Riving Knife Installation	32
Dust Collection	34
Electrical Power Connection	35
Re-Wiring the Saw for 208-240V Power	36
Electrical Schematic	37
Changing the Plug or Power Cord on a 208-240V Saw	38

TABLE OF CONTENTS

- Using Your Saw 41
 - Adjusting the Blade Height 41
 - Adjusting the Blade Tilt Angle 41
 - Turning on Main Power and Starting the Motor 42
 - System Status Codes 44
 - Using the Blade Guard 47
 - Using the Riving Knife 49
 - Using the Miter Gauge 49
 - Cross-Cutting 51
 - Using a Fence 52
 - Rip Cutting 53
 - Using the Saw in Bypass Mode 55
 - Using a Mobile Base 56
- The SawStop® Brake Cartridge 57
 - Changing the Brake Cartridge 58
 - Installing a Brake Cartridge 61
- What to do if the SawStop® Safety System Activates 62
- Making Adjustments to Your Saw 63
 - Adjusting the Elevation Limit Stops 63
 - Adjusting the Tilt Limit Stops and Tilt Angle Indicator 65
 - Adjusting the Table Insert 67
 - Aligning the Riving Knife and Spreader to the Blade 69
 - Adjusting the Height of the Riving Knife 70
 - Adjusting the Quick-Release Clamp 72
 - Adjusting the Miter Gauge 73
- Maintenance 74
 - SawStop Safety System 74
 - Brake Cartridge 74
 - Elevation and Tilt Mechanisms 74
 - Table and Extension Wings 74
 - Motor Belt 74

TABLE OF CONTENTS

Troubleshooting	75
Contractor Saw Specifications	78
Contractor Saw Dimensions	79
Push Stick Construction	81
Auxiliary Fence Construction	82
Push Block Construction	83
Featherboard Construction	84
Accessories	85
Index	86

WARRANTY

SawStop warrants to the original retail purchaser of a new Contractor Saw from an authorized SawStop distributor that the saw will be free from defects in material and workmanship for ONE YEAR from the date of purchase. SawStop warrants to the original retail purchaser of a refurbished Contractor Saw from an authorized SawStop distributor that the saw will be free from defects in material and workmanship for SIX MONTHS from the date of purchase.

This warranty does not apply to defects arising from misuse, abuse, negligence, accidents, normal wear-and-tear, unauthorized repair or alteration, or lack of maintenance. This warranty is void if the saw or any portion of the saw is modified without the prior written permission of SawStop, LLC, or if the saw is located or has been operated outside of the country where the authorized SawStop distributor from whom the saw was purchased resides.

Please contact SawStop to take advantage of this warranty. If SawStop determines the saw is defective in material or workmanship, and not due to misuse, abuse, negligence, accidents, normal wear-and-tear, unauthorized repair or alteration, or lack of maintenance, then SawStop will, at its expense, and upon proof of purchase, send replacement parts to the original retail purchaser necessary to cure the defect.

SawStop disclaims any and all other express or implied warranties, including merchantability and fitness for a particular purpose. SawStop shall not be liable for death, injuries to persons or property, or incidental, consequential, contingent or special damages arising from the use of the saw.

This warranty gives you specific legal rights. You may have other rights which, in the United States, vary from state to state.

NO WARRANTY OF SAFETY

It is important to understand that the braking technology in SawStop table saws does not prevent contact with the blade—it minimizes the effect of the contact. If you do contact the blade, the braking technology will stop the blade, and in most cases there will be no injury or only a small nick. However, you may incur a serious injury on a SawStop saw depending on factors such as the speed and direction your hand is moving when it contacts the blade and the type of blade you are using. Also, if you decide to use the saw in Bypass Mode, the safety system will be disabled and will not activate in the event you contact the spinning blade.

IF YOU HAVE AN ACCIDENT

We at SawStop hope you never have an accident with your saw, and strongly encourage you to always follow safe practices and to use all the safety equipment provided with this saw. However, if you ever accidentally contact the spinning blade, the safety system will detect that contact and stop the blade within milliseconds to minimize any injury. If this happens, please contact us with information regarding the accident because it is very important to our on-going research and development. The more we know about what happens during an accident, the better we are able to ensure that the safety system will react as quickly as possible in all accident situations. In addition, the brake cartridges store electronic data measured during an accident. If you return the activated cartridge to SawStop, we can retrieve that data to learn how the electronics and software performed. If we confirm that your cartridge activated due to skin contact, we will send you a free replacement cartridge. Thanks for your help.

SAFETY

A table saw is a dangerous tool and there are hazards inherent with using this saw. Some of these hazards are discussed below. Use common sense when operating the saw and use the saw only as instructed. **You are responsible for your own safety!**

WARNINGS

1. Read and understand the instruction manual and all safety warnings before operating this saw. Failure to follow instructions or heed warnings may result in electric shock, fire, serious personal injury or property damage. Save these instructions and refer to them whenever necessary.
2.  **WARNING:** This product can expose you to chemicals including wood dust, which is known to the State of California to cause cancer. For more information, go to www.P65Warnings.ca.gov. In addition, some types of dust created by sawing, power sanding, grinding, drilling, and other construction activities also contain chemicals known to cause cancer, birth defects or other reproductive harm. Some examples of these chemicals are lead from lead-based paints, crystalline silica from bricks, cement, and other masonry products, and arsenic and chromium from chemically treated lumber. The risk from exposure to these chemicals and to dust varies depending on how often you do this type of work. To reduce your exposure, work in a well-ventilated area and work with approved safety equipment including dust masks or respirators designed to filter out such dust and chemicals.
3. **This saw must be connected to a grounded wiring system** or to a system having an equipment-grounding conductor. In the event of a malfunction or breakdown, grounding provides a path of least resistance for electric current to reduce the risk of electric shock. This saw is equipped with an electric cord having an equipment-grounding conductor and a grounding plug. The plug must be plugged into a matching outlet that is properly installed and grounded in accordance with all local codes and ordinances. Do not modify the plug provided - if it will not fit the outlet; have the proper outlet installed by a qualified electrician. Improper connection of the equipment-grounding conductor can result in a risk of electric shock and/or malfunction. The conductor with insulation having an outer surface that is green with or without yellow stripes is the equipment-grounding conductor. If repair or replacement of the electric cord or plug is necessary, do not connect the equipment-grounding conductor to a live terminal.

Check with a qualified electrician or service personnel if the grounding instructions are not completely understood or if in doubt as to whether the saw is properly grounded. Use only 3-wire extension cords that have 3-prong grounding plugs and 3-pole receptacles that accept the saw's plug. Repair or replace a damaged or worn cord immediately.

Minimum Extension Cord Gauge for 110-120V	
Length	Gauge
0 - 25 Feet	12 AWG
25 - 50 Feet	10 AWG
over 50 Feet	Not Recommended

4. **Use a proper extension cord** and make sure that it is in good condition. When using an extension cord, be sure to use one heavy enough to carry the current your saw will draw. An undersized cord will cause a drop in line voltage resulting in loss of power and overheating. For a cord length of up to 25 feet, use a cord of 12 gauge. For a cord length of 25 to 50 feet, use a cord of 10 gauge. A cord length over 50 feet is not recommended for 110-120V power. If in doubt, use the next heavier gauge. The smaller the gauge number the heavier the cord.
5. The Contractor Saw in its standard configuration is intended for use on a 110-120V supply circuit that has an outlet that looks like the one illustrated in Sketch A below.

SAFETY

WARNINGS

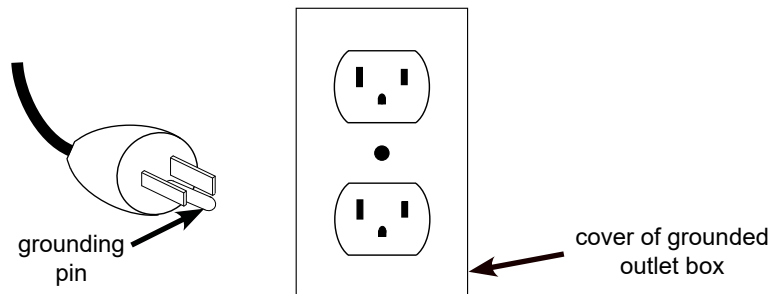

Sketch A

A temporary adapter, which looks like the adapter illustrated in Sketch B and C, may be used to connect this plug to a 2 pole receptacle as shown in Sketch B if a properly grounded outlet is not available. The temporary adapter should be used only until a properly grounded outlet can be installed by a qualified electrician. This adapter is not permitted in Canada. The green-colored rigid ear, lug, and the like, extending from the adapter must be connected to a permanent ground such as a properly grounded outlet box.

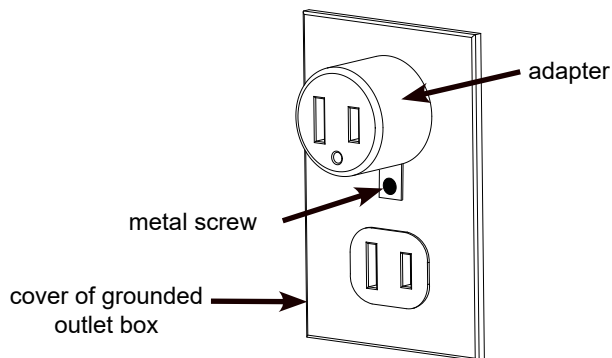

Sketch B

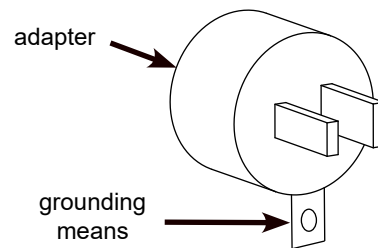

Sketch C

6. A Contractor Saw that has been re-wired for 208-240V power is intended for use on a circuit that has an outlet that looks like the one illustrated in Sketch D. The saw has a grounding plug that looks like the plug illustrated in Sketch D. Make sure the saw is connected to an outlet having the same configuration as the plug. No adapter is available or should be used with this saw. If the saw must be reconnected for use on a different type of electric circuit, the reconnection should be made by qualified service personnel; and after reconnection, the saw should comply with all local codes and ordinances.

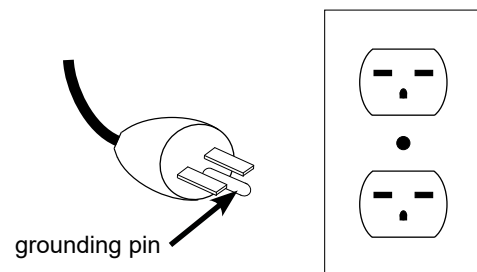

Sketch D

SAFETY



WARNINGS

7. Keep children away from the saw. All visitors should be kept at a safe distance from the work area. Make the workshop kid-proof with padlocks, master switches, or by removing starter keys.
8. Do not use the saw in dangerous environments. For example, do not use the saw in damp or wet locations or expose it to rain, and keep the work area well lighted.
9. Check to make sure the saw is in proper working order before using the saw. For example, check the alignment of moving parts, look to see whether moving parts are binding or rubbing, check to see whether parts are broken, make sure accessories are properly mounted in the saw, and check any other conditions that may affect the operation of the saw. A guard or other part that is damaged should be properly repaired or replaced.
10. Keep guards in place and in working order. Never operate the saw with the belt guard open.
11. Wear eye protection. Always wear safety glasses when using the saw. Everyday eyeglasses are not safety glasses. Also use a face or dust mask if the cutting operation is dusty.
12. Wear proper apparel when using the saw. Do not wear loose clothing, gloves, neckties, rings, bracelets, or other jewelry which may get caught in moving parts. Non-slip footwear is recommended. Wear a protective hair covering to contain long hair.
13. You must install a rip fence before using this saw. Attempting to use the saw for rip cutting without the rip fence could result in serious personal injury.
14. Reduce the risk of unintentional starting by making sure the power switch is in the OFF position before plugging in the saw. Also, remove adjusting wrenches from the saw before turning it on.
15. Keep hands out of the line of the saw blade. Never reach around or over the saw. Do not overreach or stretch to get something when using the saw. Keep proper footing and balance at all times.
16. Never stand on the saw. Serious injury could occur if the saw is tipped or if the cutting tool is unintentionally contacted.
17. Feed work into the blade against the direction of rotation of the blade only. Feeding the work in the direction of rotation may cause the work to be thrown by the blade and could result in serious personal injury.
18. Do not perform any operation freehand. Freehand means not using a fence (for rip cuts) or a miter gauge (for cross-cuts) to guide the work piece as it is being cut. Always maintain firm control over the material being cut.
19. Use a blade guard and spreader for every operation for which it can be used, including all through sawing. Use a push stick when required.
20. Secure your work. Use clamps or a vise to hold work when practical. It's safer than using your hand and it frees both hands to operate tool.
21. Pay particular attention to instructions on reducing the risk of kickback. Kickback occurs when a work piece contacts the downstream edge of the blade as it is being cut and is propelled back towards the user at high velocity.

SAFETY



WARNINGS

22. Don't force the tool; it will do the job better and safer at the rate for which it was designed. For example, do not try to cut wood faster than the motor can handle.
23. Use the right tool. Do not try to force the saw to do something it was not designed to do. Don't force a tool or attachment to do a job for which it was not designed. Use the right blade for the job.
24. Never leave the saw running unattended. Wait until the blade comes to a complete stop and then turn the main power switch to **OFF** and unplug the power cord when you are finished using the saw.
25. Turn the main power switch to **OFF** and unplug the power cord before servicing the saw and when changing components or accessories such as blades, brake cartridges, and the like.
26. Maintain the saw as specified in this manual. Keep tools sharp and clean for best and safest performance. Follow instructions for lubrication and changing accessories.
27. Use only recommended accessories with the saw. Consult this manual for recommended accessories. The use of improper accessories may cause risk of injury. When servicing, use only identical replacement parts.
28. Keep the top of the saw clean and free from clutter. Cluttered areas invite accidents.

WARNING LABELS

Warning labels are mounted on the left side of the saw, on the switch box, on the belt guard, and on the blade guard. Some of the warnings on those labels may be additional to the warnings listed above. Be sure to read the warning labels before using the saw. Copies of some of the English text of the warning labels are reproduced below:

⚠ WARNING

To avoid loss of SawStop protection during coast down, do not turn off Main Power until blade has stopped spinning.

⚠ WARNING

Do not remove the dust shroud because the blade will be exposed. If you contact the blade under the table, the blade may retract toward you and cause a severe injury.

⚠ WARNING



Moving belts and parts can pinch, cut or crush.

Do not operate with belt guard open.

⚠ WARNING

For your own safety, read the instruction manual before operating this saw.

1. Wear eye protection.
2. Use the blade guard and spreader for every operation for which it can be used, including all through sawing.
3. Keep hands out of the line of the saw blade.
4. Use a push-stick when required.
5. Know how to reduce the risk of kickback.
6. Do not perform any operation freehand.
7. Never reach around or over the saw blade.
8. Never try to test fire the brake system.
9. Never adjust the position of the brake cartridge while the blade is spinning.
10. Do not try to disable the brake system.
11. Unplug the saw before changing the blade, changing the brake cartridge or servicing.
12. Do not connect the motor directly to a power supply.
13. Use the bypass switch only when necessary.
14. Do not expose to rain or use in damp locations.
15. Do not put your hands inside or underneath the cabinet while the blade is spinning.
16. Do not unplug or disconnect the saw from electrical power before the blade has stopped spinning.

THE SAWSTOP® SAFETY SYSTEM

This Contractor Saw is equipped with the SawStop® safety system. This revolutionary technology was developed to reduce the potential for a serious injury in the event of accidental contact with the saw blade. SawStop® saws are the only saws smart enough to know the difference between you and the wood you are cutting.

The SawStop® safety system includes two components, an electronic detection unit and a fast-acting brake. The electronic detection unit detects when a person contacts the blade. A small electrical signal is induced onto the blade by electrodes placed around the arbor. Although this low voltage, high frequency signal is too small to feel, it can be measured by the detection system. When human skin comes into contact with the blade (or arbor), a portion of the signal is absorbed by the body due to the inherent electrical capacitance of the human body. As a result, the signal on the blade gets smaller and the detection unit recognizes this as contact.

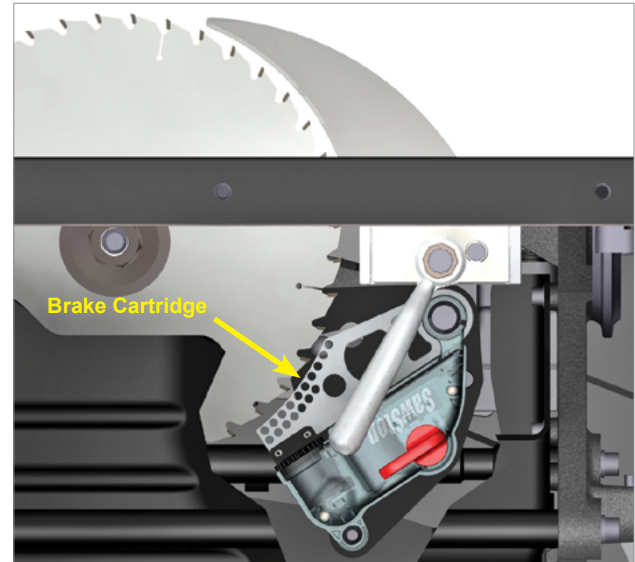

Wood and other non-conductive materials such as plastic, foam, cardboard, Corian®, melamine, etc., do not cause a drop in the signal because those materials do not absorb the signal on the blade. Conductive materials such as aluminum and other metals, carbon fiber materials, mirrored acrylic, carbon-filled materials, etc., will typically cause the brake to activate. If you need to cut these conductive materials, the safety system can be placed in “Bypass Mode” to temporarily disable the brake. (The Bypass Mode is discussed [on page 55](#).)

The fast-acting brake includes a small fuse that holds a strong spring in compression. If the electronic detection unit detects contact while the blade is spinning (including during coast down), the fuse is burned by a surge of electric current. The spring then pushes an aluminum pawl into the teeth of the spinning blade. The teeth cut into the pawl, stopping the blade. The total time between the detection of contact and stopping the blade is just a few milliseconds. If the brake is activated while the blade is at or near full speed, the blade will also quickly retract below the table. The system will not activate the brake when the blade is stopped—even if you spin the blade by hand. This allows you to touch or change the blade when the motor is off just as with ordinary table saws. However, for safety, always turn the main power switch to OFF and unplug the power cord when changing the blade.

The SawStop® safety system is active whenever the main power is on. The safety system continuously performs many different self-checks to ensure that the components of the system are operating properly. If any problems are detected, the safety system will disable the motor and display a system status code to identify the problem ([see page 44](#) for a description of the system status codes and the corrective action). If the problem is detected while the motor is spinning, the motor will be shut off. The safety system will not allow the motor to start, even in Bypass Mode, as long as a problem is detected.

The electronic detection unit and fast-acting brake are contained in the “brake cartridge,” which is positioned under the table and just behind the blade, as shown above. The brake cartridge must be correctly installed before the motor can be started ([see page 58](#) for instructions on removing and installing the brake cartridge). In the event that the brake is activated, a new brake cartridge must be installed before the saw can be used again.

THE SAWSTOP® SAFETY SYSTEM

The SawStop® safety system does not interfere with your use of the saw. You can still make all the cuts that you can with ordinary saws including 0° to 45° bevels, non-through cuts, and dado cuts (with the optional dado brake cartridge and the optional dado table insert).

Your SawStop® saw operates differently than ordinary table saws, and there are a few important points to keep in mind as you use the saw.

1. Do not rely on the SawStop® safety system to protect against unsafe operation. Although the system is designed to react and stop the blade very quickly in the event of accidental contact, it cannot react until contact is detected. This means that you may receive at least a minor injury even with the SawStop® safety system. Therefore, always use safe operating practices, and use the blade guard, push stick and other safety devices whenever possible. The SawStop® safety system, like the airbag in a car, should be considered as a last measure to minimize injury when all other safety practices and devices have failed to prevent an accident.
2. In the event of contact, the blade will be stopped in about 3–5 milliseconds (coarse toothed blades stop more quickly than fine-toothed blades such as plywood blades). Therefore, the seriousness of the injury incurred will depend on the speed at which a person's hand or other body part is moving toward the blade. For example, if a person's hand is moving toward the blade at 1 ft./sec., then the depth of the cut will be approximately 1/16 inch (1 ft./sec.* 0.005 sec. = 0.005 ft. or 1/16 inch). At faster speeds, the cut will be proportionally deeper. Therefore, it is possible to be seriously injured even with the SawStop® safety system.
3. Do not operate the saw in Bypass Mode unless you are cutting electrically conductive material. When Bypass Mode is engaged, the SawStop® safety system will not activate the brake if contact is detected and a serious injury could result if you contact the blade.
4. The motor cannot be started without a blade installed. Since the safety system disables the motor if the blade is spaced too far from the brake, a missing blade will be detected as a blade-to-brake spacing error and the motor will be disabled.
5. Blades

You can use any standard 10 inch saw blade or 8 inch dado set with your SawStop® saw, although the following precautions should be observed:

- i. Never attempt to use a blade other than a single 10 inch blade with the standard SawStop® brake cartridge. Never attempt to use a dado set or blade other than an 8 inch dado set with the SawStop® dado cartridge. The use of smaller diameter blades with a brake cartridge designed for larger blades could result in a serious injury because the brake cannot be positioned correctly to stop the smaller blades.
- ii. Never stack dado blades thicker than 13/16 inch. The 8 inch dado brake cartridge is not designed to stop dado stacks thicker than 29/32 inch.
- iii. Do not use molding heads. The use of molding heads could result in a serious injury because neither the standard brake cartridge nor the dado brake cartridge is designed to stop a molding head.
- iv. Never use a blade with damaged or missing teeth as this can result in a more serious injury or a false activation of the brake. Blades with variable spacing between teeth are compatible with the SawStop® safety system, however you must ensure the brake is positioned correctly by rotating the blade at least one full revolution to be certain that none of the teeth touch the brake ([see page 30](#) for more information on setting the brake position).
- v. Never install the blade backwards. The brake might not stop a blade that is installed backwards.
- vi. Do not use saw blades or dado sets that have a lacquer or other coating on the teeth. These coatings are non-conductive and therefore can reduce the speed at which the system detects contact. In other words, a coated tooth must cut slightly deeper into the skin for contact to be detected, resulting in a somewhat more serious injury. Used blades that originally had a coating are OK to use since the coating is worn away within a few uses. However, SawStop recommends that you examine each tooth on such blades to confirm that no coating remains.
- vii. Blades with depth-limiting shoulders may take longer to stop in the event of an accident than standard

THE SAWSTOP® SAFETY SYSTEM

blades, and you could receive a more serious injury. Therefore, SawStop recommends using blades without depth-limiting shoulders.

- viii. The SawStop safety system is designed for use with standard 10 inch blades with kerfs from 3/32 inch to 3/16 inch. Blades with kerfs much thinner than 3/32 inch should not be used because those blades might not be strong enough to withstand the force applied by the brake when it activates. As a result, those blades might deform and stop more slowly in the event of an accident, resulting in a more serious injury. Blades with kerfs much thicker than 3/16 inch are heavier than standard 1/8 inch kerf blades, and should not be used because they may stop more slowly than standard blades in the event of an accident, resulting in a more serious injury. Similarly, stacks of two or more 10 inch blades should never be used on your SawStop saw as the combined weight of the blades may be too heavy to stop quickly. If you need to use a blade with a kerf thicker than 3/16 inch, use an 8 inch dado set with the optional Sawstop 8 inch dado brake cartridge.
- ix. Do not use non-conductive blades, including abrasive blades, blades with plastic hubs, or blades that have non-conductive teeth. The safety system cannot induce the electrical signal onto a non-conductive blade, and blades with non-conductive teeth may prevent the system from detecting contact. Only standard steel blades with either steel or carbide teeth should be used.
6. Do not use table inserts, guards, fences or other devices which have metal parts that may come into contact with the blade. Any metal part that contacts the blade may cause the brake to activate. All SawStop® accessories are specifically designed to prevent metal contact with the blade.
7. Wet, pressure-treated wood may cause the brake to activate. The chemicals used to pressure treat wood often contain large amounts of copper, which is conductive. When pressure-treated wood is wet, the combination of copper and water substantially increases the conductivity of the wood. Therefore, allow wet pressure-treated wood to fully dry before cutting. Typically, the wood will be sufficiently dry if left unstacked in a dry location for 24 hours. If you must cut wet pressure-treated wood, you can make several cuts in the wettest piece(s) using the Bypass Mode to test whether the wood is too wet. [See page 55](#) for instructions on using Bypass Mode and [page 46](#) for information on testing the conductivity of a material. If the test indicates the wood is too wet to cut with the safety system active, you must either allow the wood to dry or make the remaining cuts in Bypass Mode.
8. Do not replace the arbor belt with a non-SawStop® belt. The SawStop® arbor belt is custom designed to dissipate static electricity that may build up on the spinning blade which could cause a false activation of the brake.
9. Never touch the arbor, arbor pulley, arbor nut or arbor washer when the blade is spinning because you may receive a serious injury. These parts are all electrically coupled to the blade and the brake will activate if contact with these parts is detected.
10. Never reach under the blade while it is spinning. In the event the brake is activated, the retraction of the blade may cause a serious injury if you contact the bottom of the blade.
11. Do not remove the dust shroud because a large portion of the blade will be exposed. If you contact the blade under the table, the blade may retract toward you and cause a severe injury.
12. Do not unplug or disconnect the saw from electrical power before the blade has stopped spinning. If the power is interrupted while the blade is moving, the safety system will not be active and therefore the brake will not activate in the event of accidental contact. You may receive a serious injury if you contact the spinning blade while the electrical power has been interrupted.
13. Never attempt to disable the SawStop® safety system or modify the electrical wiring of the saw in any way. Any change or modification or disablement of the safety system or other wiring could result in a serious injury and will void all warranties.
14. Never attempt to repair, adjust, modify or otherwise service a brake cartridge. There are no user-serviceable parts inside the brake cartridge. The brake cartridge is permanently sealed against dust and other contaminants. Destruction, removal, or alteration of this seal voids all warranties.

UNPACKING YOUR SAW



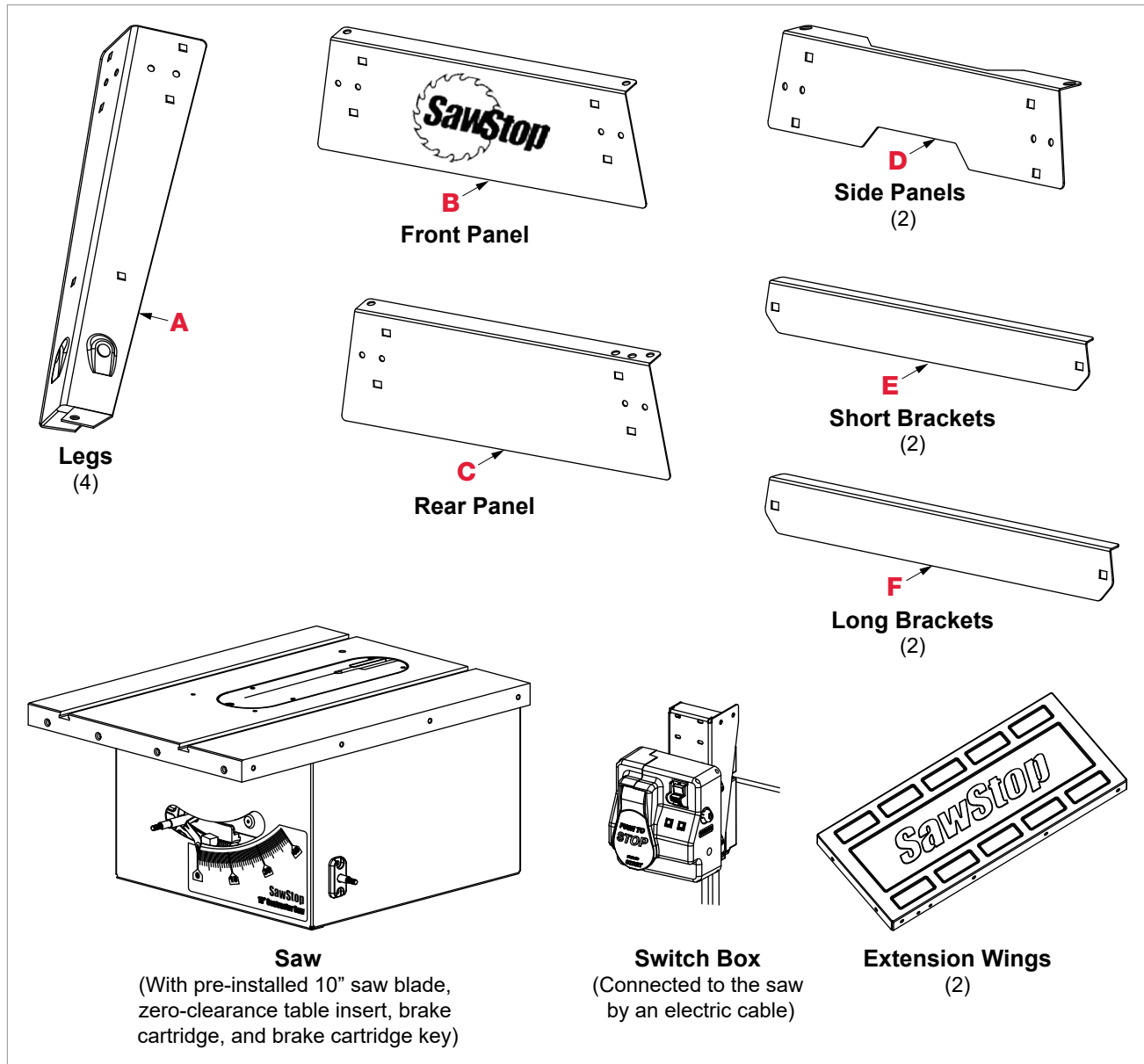

While unpacking your saw verify that all the components shown on this page and the following page are included. Use care when unpacking your saw to prevent damage to any of the saw components or accessories. Read and understand this manual fully before assembling and operating your saw.

Fig. 1

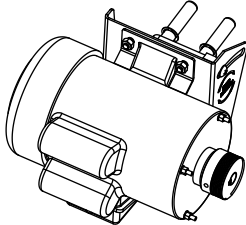
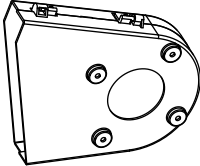

UNPACKING YOUR SAW

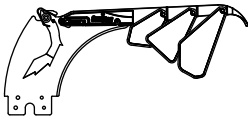
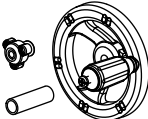
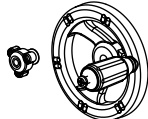
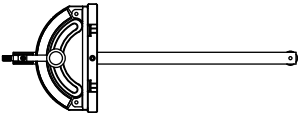
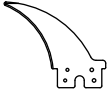
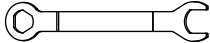
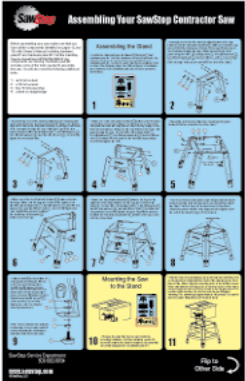
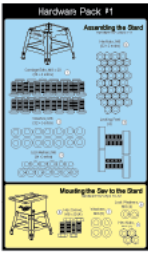
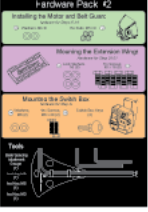
Fig. 2

			
<p>Motor</p>	<p>Belt Guard</p>	<p>Motor Belt</p>	
			
<p>Blade Guard Assembly</p>	<p>Elevation Handwheel Package</p>	<p>Tilt Handwheel Package</p>	
			
<p>Miter Gauge</p>	<p>Riving Knife (pre-installed)</p>	<p>Blade Wrenches (two)</p>	
			
<p>Assembly Instructions Poster</p>	<p>Hardware Pack #1</p>	<p>Hardware Pack #2</p>	<p>Owner's Manual</p>

ASSEMBLING YOUR SAW

The instructions to assemble your saw are on a poster included with your saw and are listed below. You can follow either set of instructions to assemble your saw. In addition to the tools included with hardware pack #2 you will also need the following tools to complete the assembly: an 8 mm socket, a 10 mm wrench, two 13 mm wrenches, and a level or straight edge.

Assembling the Stand

1. Locate the stand components labeled **A** through **F** and Hardware Pack #1 (see Fig. 3). All of the hardware needed to assemble the stand is located in the area with the blue background on Hardware Pack #1. In order to easily identify the hardware used in each of the following steps, the different pieces of hardware are numbered on the hardware pack and in the figures.

Fig. 3

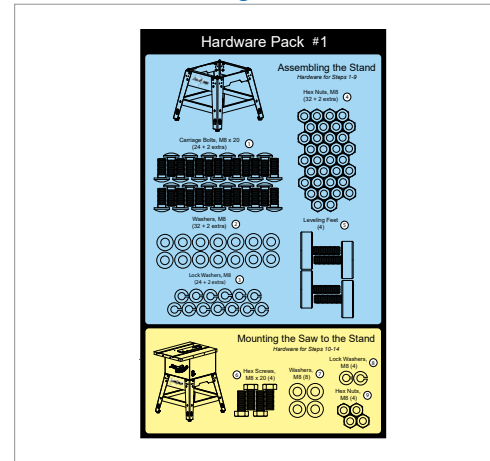

2. Assemble the front of the stand by attaching two of the legs marked **A** to the front panel marked **B** (see Fig. 4). Make sure that the legs are in front of the front panel. Bumps on the legs fit into holes in the front panel to align the legs. Attach the legs to the front panel using four M8 x 20 carriage bolts, four M8 washers, four M8 lock washers, and four M8 hex nuts. Do not fully tighten the nuts at this time. Leaving the nuts loose will make it easier to align holes as you assemble the rest of the stand.

Fig. 4

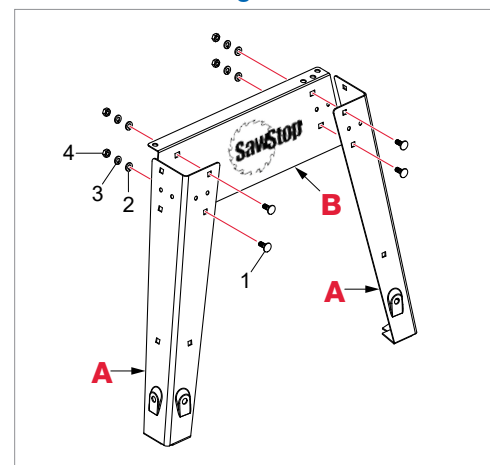

3. Assemble the rear of the stand by attaching the remaining two legs marked **A** to the rear panel marked **C** (see Fig. 5). Make sure that the legs are in front of the rear panel. Bumps on the legs fit into holes in the rear panel to align the legs. Attach the legs to the rear panel using four M8 x 20 carriage bolts, four M8 washers, four M8 lock washers, and four M8 hex nuts. Do not fully tighten the nuts at this time.

Fig. 5

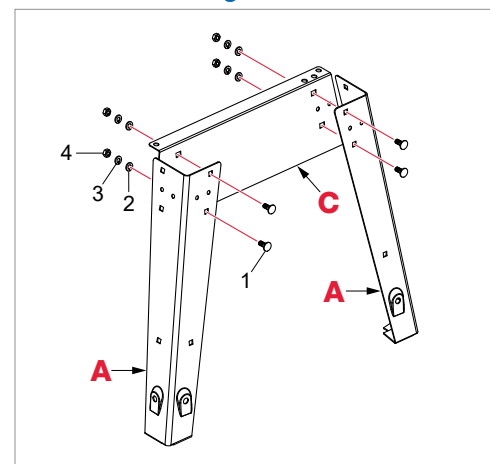

ASSEMBLING YOUR SAW

4. Attach one of the side panels marked **D** between the front and rear portions of the stand (see Fig. 6). Make sure the legs are in front of the side panel and that the side panel is under the top flanges of the front and rear panels. Bumps on the legs fit into holes in the side panel to align the legs. Use four M8 x 20 carriage bolts, four M8 washers, four M8 lock washers, and four M8 hex nuts to attach the side panel to the front and rear portions. Do not fully tighten the nuts.

Fig. 6

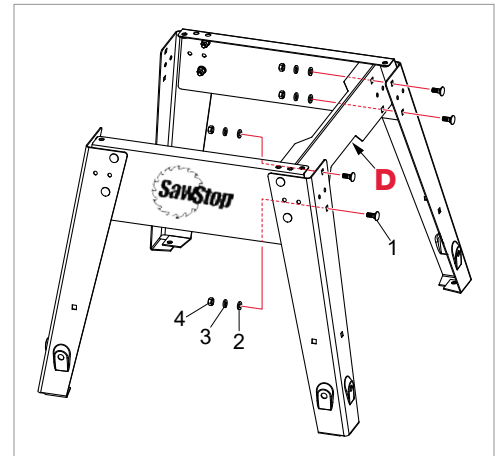

5. Repeat the prior step to attach the remaining side panel marked **D** to the opposite side of the stand (see Fig. 7).

Fig. 7

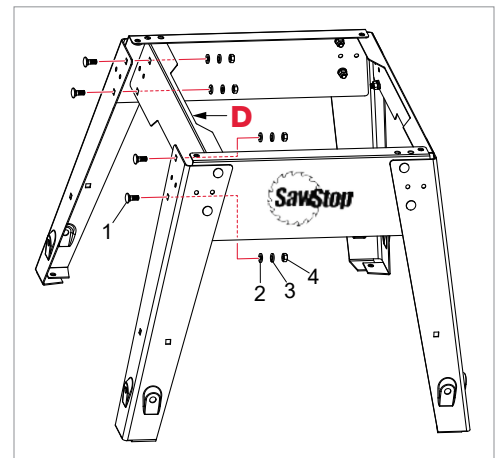

6. Attach one of the short brackets marked **E** between the two front legs (see Fig. 8). Make sure the legs are in front of the bracket. Use two M8 x 20 carriage bolts, two M8 washers, two M8 lock washers, and two M8 hex nuts. Do not fully tighten the nuts. Repeat this process to attach the remaining short bracket **E** between the rear legs.

Fig. 8

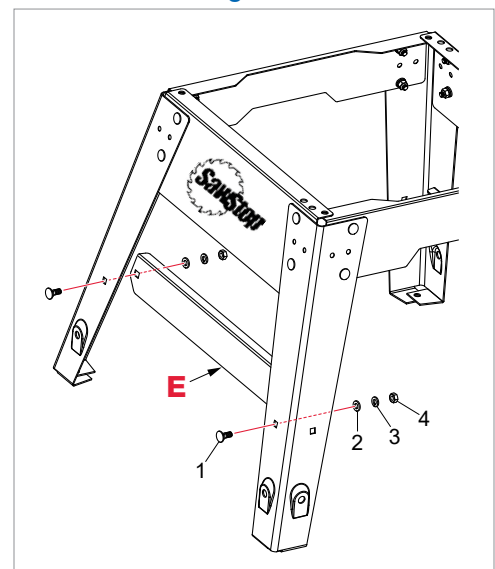

ASSEMBLING YOUR SAW

- Attach one long bracket marked **F** between the legs on the right side of the stand (see Fig. 9). Make sure the legs are in front of the brackets. Use two M8 x 20 carriage bolts, two M8 washers, two M8 lock washers, and two M8 hex nuts to attach the long bracket. Do not fully tighten the nuts. Repeat this process to attach the remaining long bracket between the legs on the left side of the stand.

Tip: If you have purchased the optional mobile base, consider installing it now before adding the weight of the saw to the stand. To ease the assembly process, delay installation of the bolts for one side of bracket **F** until after the stand has been placed onto the assembled mobile base.

Fig. 9

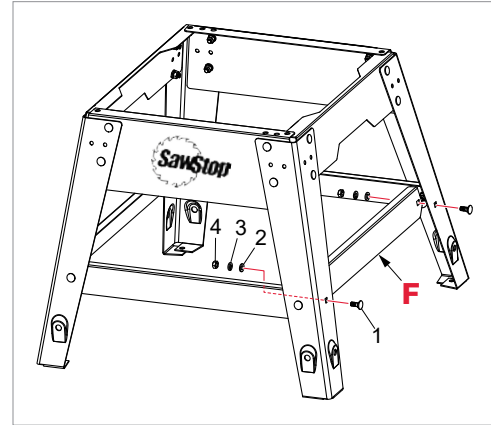

- The front, rear and side panels have flanges that overlap to define mounting holes through which you will bolt the saw to the stand. There is one hole in each corner of the stand (see Fig. 10). Adjust the panels until the holes align and then tighten all of the nuts in the stand using a 13 mm wrench.

Fig. 10

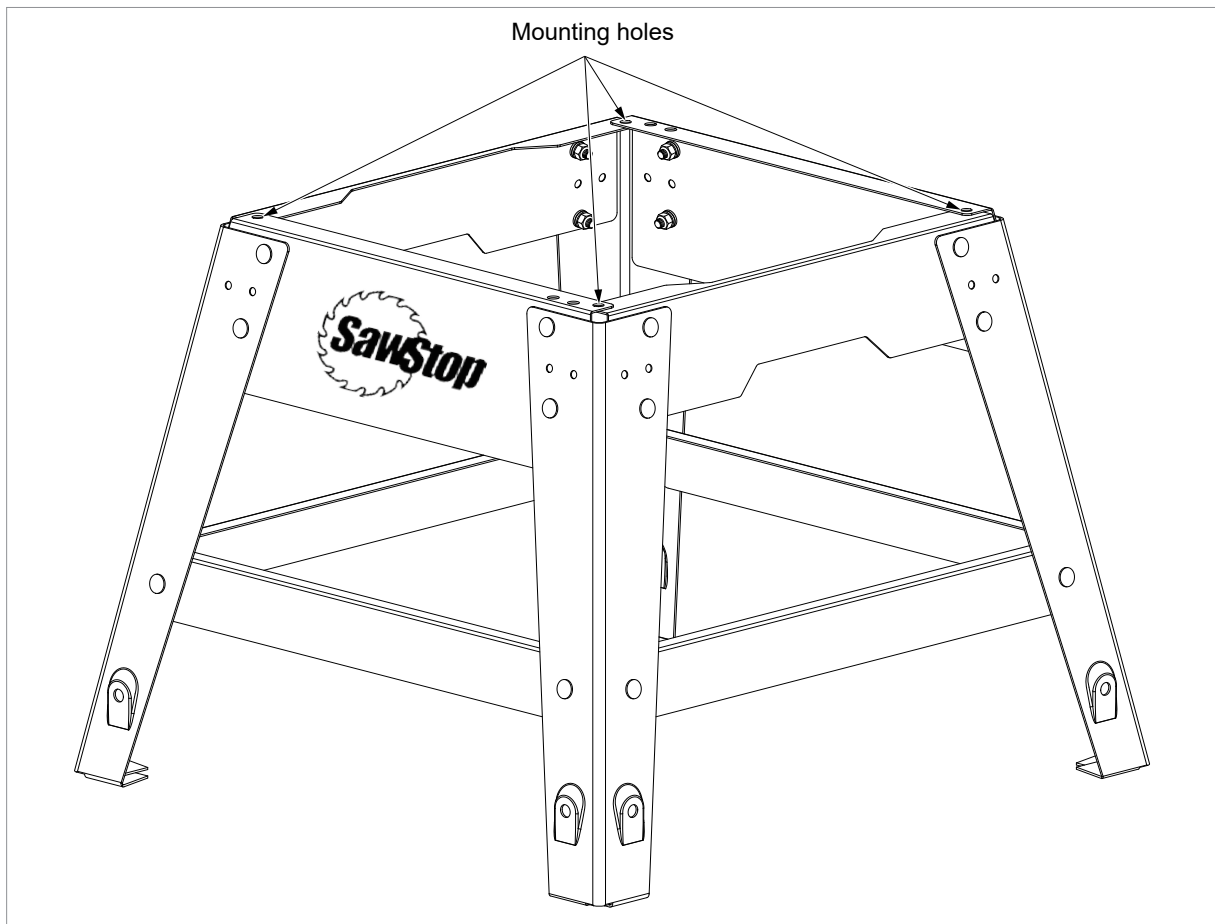

ASSEMBLING YOUR SAW

- Attach a foot to the bottom of each leg as shown in **Fig. 11** by threading an M8 hex nut on each foot and then placing an M8 washer over the nut. Insert a foot into the hole at the base of each leg and then place a second M8 washer and thread a second M8 hex nut onto each foot. Do not fully tighten the nuts. The stand is now fully assembled.

Note: If you purchased an optional SawStop® Contractor Saw Mobile Base for your saw, install it now by following the instructions that came with the mobile base.

Fig. 11

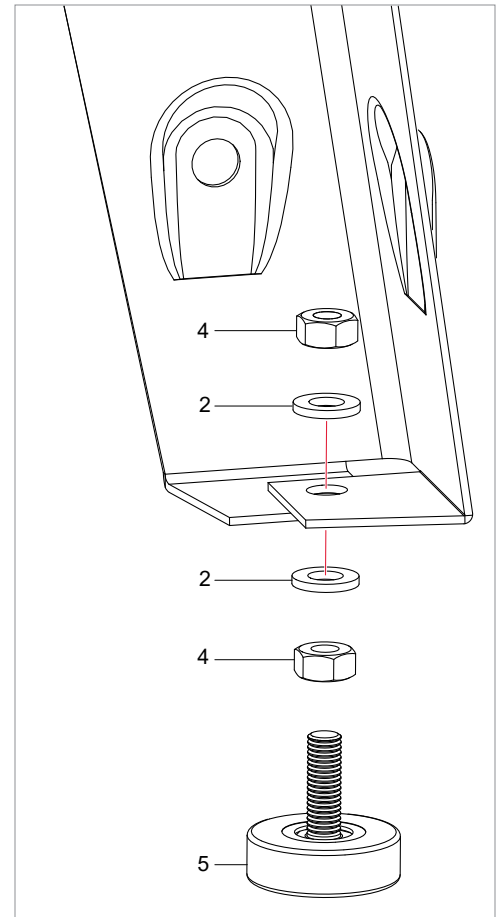

Mounting the Saw to the Stand

- Remove the saw from the box and locate the mounting hardware. All of the hardware needed to mount the saw to the stand is located in the area with the yellow background on Hardware Pack #1 (see **Fig. 12**).

Fig. 12

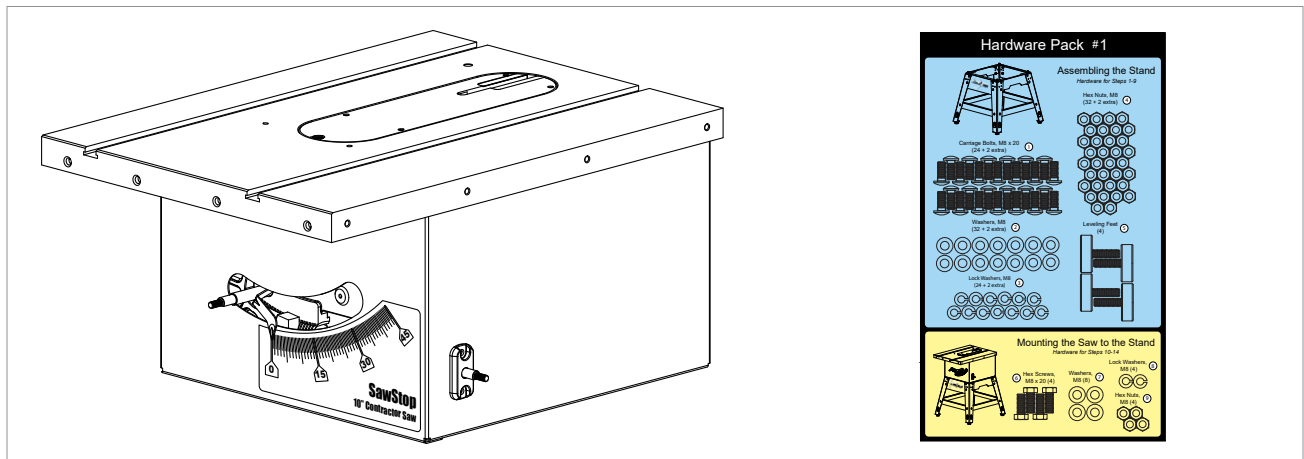

ASSEMBLING YOUR SAW

11. With the help of an assistant, pick up the saw and carefully set it on the assembled stand with the front of the saw above the front panel of the stand (see Fig. 13). Align the mounting holes in the bottom corners of the saw with the mounting holes in the top corners of the stand. While moving the saw do not set it down in the upright position on a solid surface because the dust shroud can be damaged.

WARNING! The saw weighs approximately 140 pounds. Be careful and use proper lifting technique to avoid injury.

Fig. 13

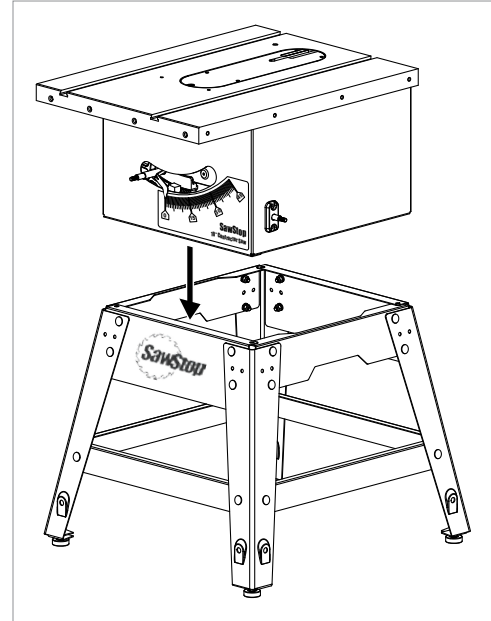

12. Mount the cabinet to the stand using four M8 x 20 hex screws, eight M8 washers, four M8 lock washers, and four M8 hex nuts. Insert the hex screws down through the mounting holes in the bottom corners of the saw and the top corners of the stand, and thread the hex nuts on from the bottom (see Fig. 14). Make sure to place a washer between the screw head and the saw and to place a washer and lock washer above each nut with the lock washer next to the nut, as shown. Fully tighten all of the nuts using two 13 mm wrenches.

Fig. 14

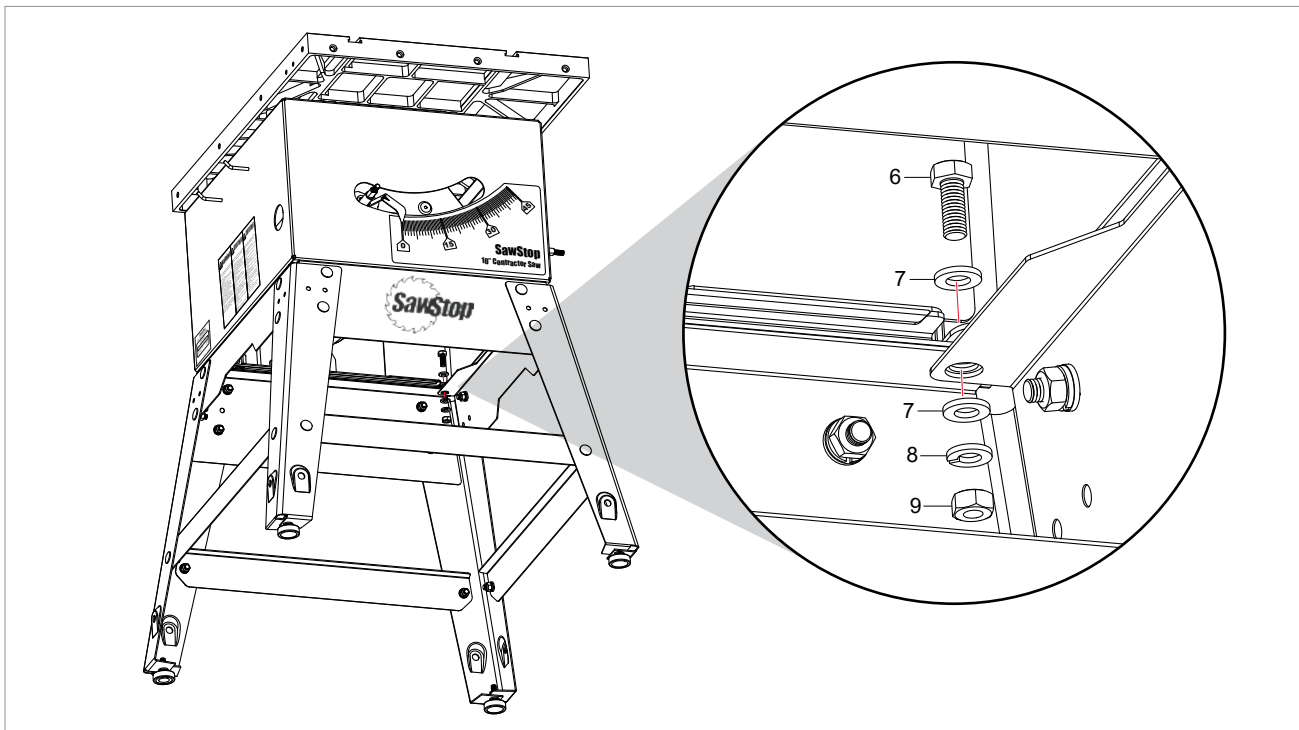

ASSEMBLING YOUR SAW

13. Remove the plastic covering from the cast iron table top and remove the yellow label from the top of the table insert. Wipe the oil off the table top with a soft, clean cloth (see **Fig. 15**). The table top is shipped with a coating of oil to prevent the cast iron from rusting.

Fig. 15

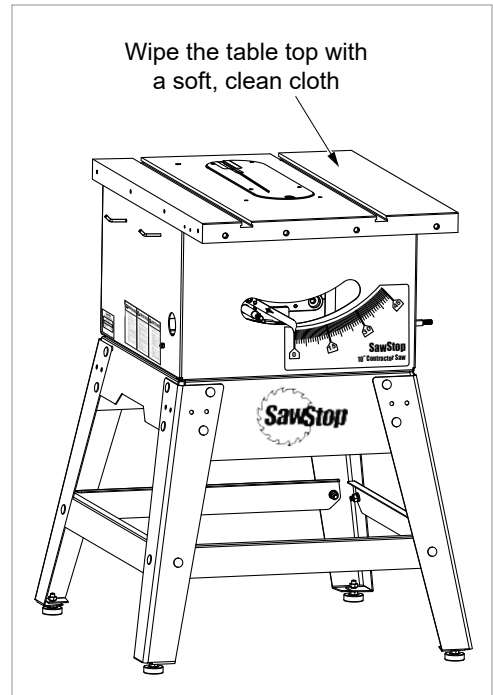

14. Place a level across the table top and adjust the four feet of the stand by turning the lower hex nuts until the table top is level (you may need to loosen the upper hex nuts). When the saw is level, tighten each of the upper hex nuts with a 13 mm wrench while holding the foot against rotation (see **Fig. 16**).

Fig. 16

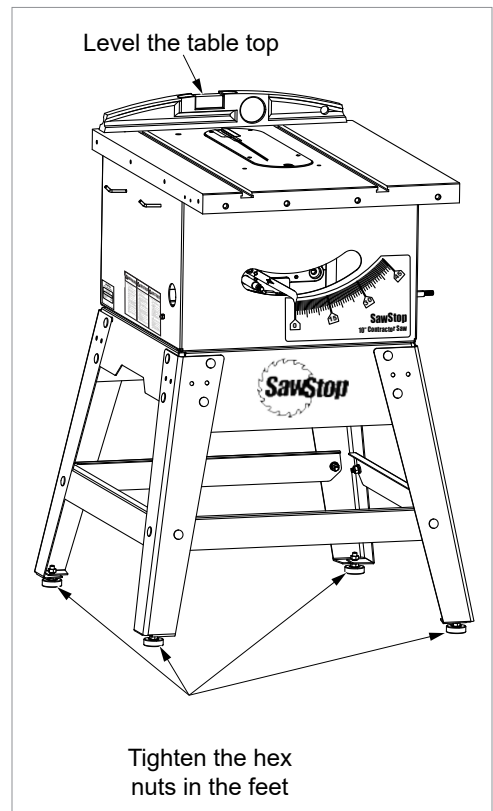

ASSEMBLING YOUR SAW

Installing the Elevation Hand-Wheel

15. Open the elevation hand-wheel package and remove the 25/8 inch long plastic spacer tube. Slide the tube as far as possible onto the elevation control shaft that extends out from the front of the saw (see Fig. 17). Next, slide the hand-wheel onto the same shaft. Finally, thread the elevation lock knob onto the shaft.

Fig. 17

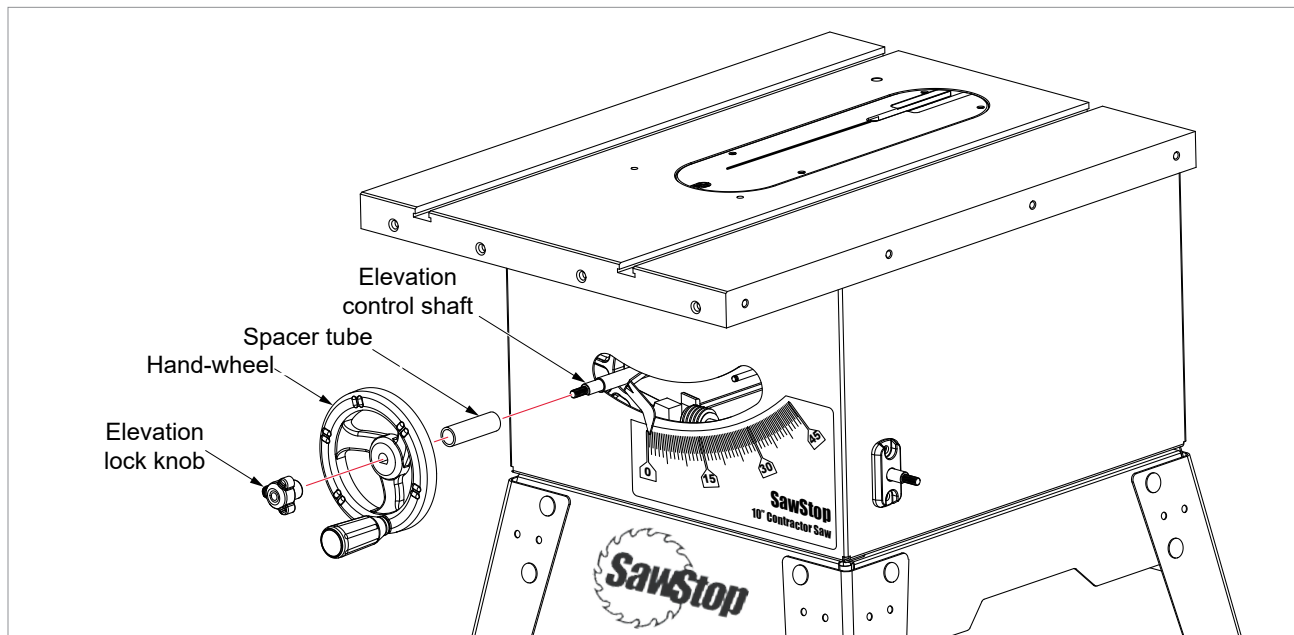

Installing the Tilt Hand-Wheel

16. Open the blade tilt package and slide the hand-wheel onto the tilt control shaft and then thread the tilt lock knob onto the shaft (see Fig. 18).

Fig. 18

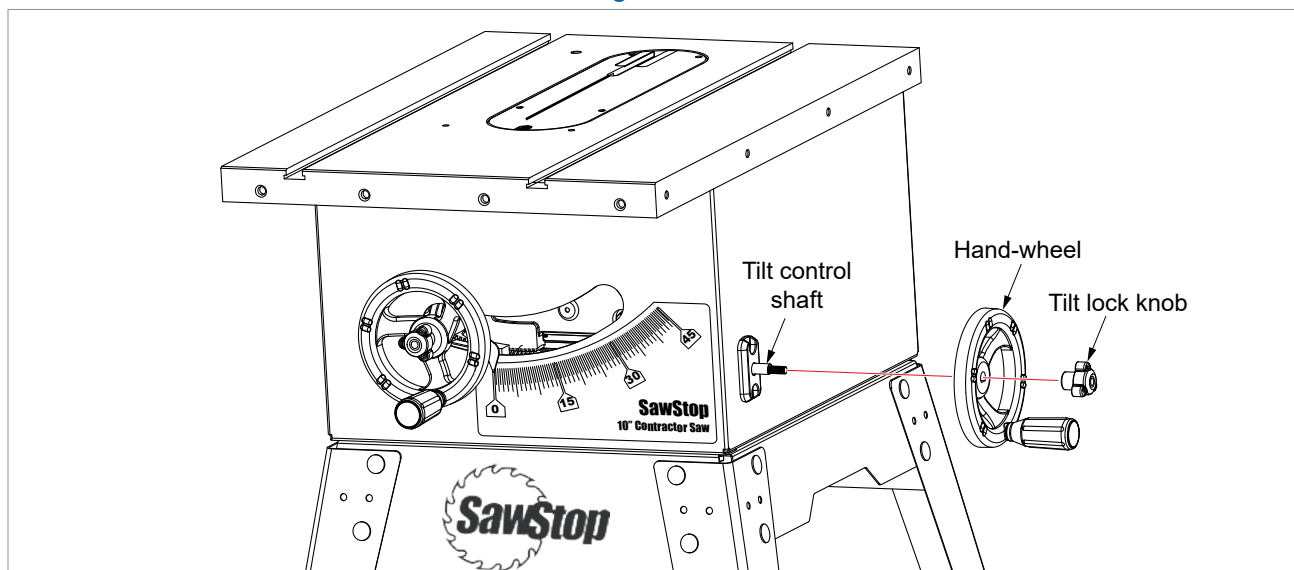

ASSEMBLING YOUR SAW

Installing the Motor and Belt Guard

17. Locate the motor, the motor belt, the belt guard, and hardware pack #2. All of the hardware needed to install the motor and belt guard is located in the area with the green background on hardware pack #2. Attach the motor to the saw by sliding the motor mounting pins into the corresponding holes in the rear trunnion (see Fig. 19). Make sure the pins slide all the way into the holes. Use the 3 mm hex key included with hardware pack #2 to tighten the two lock down set screws to hold the motor in place.

Fig. 19

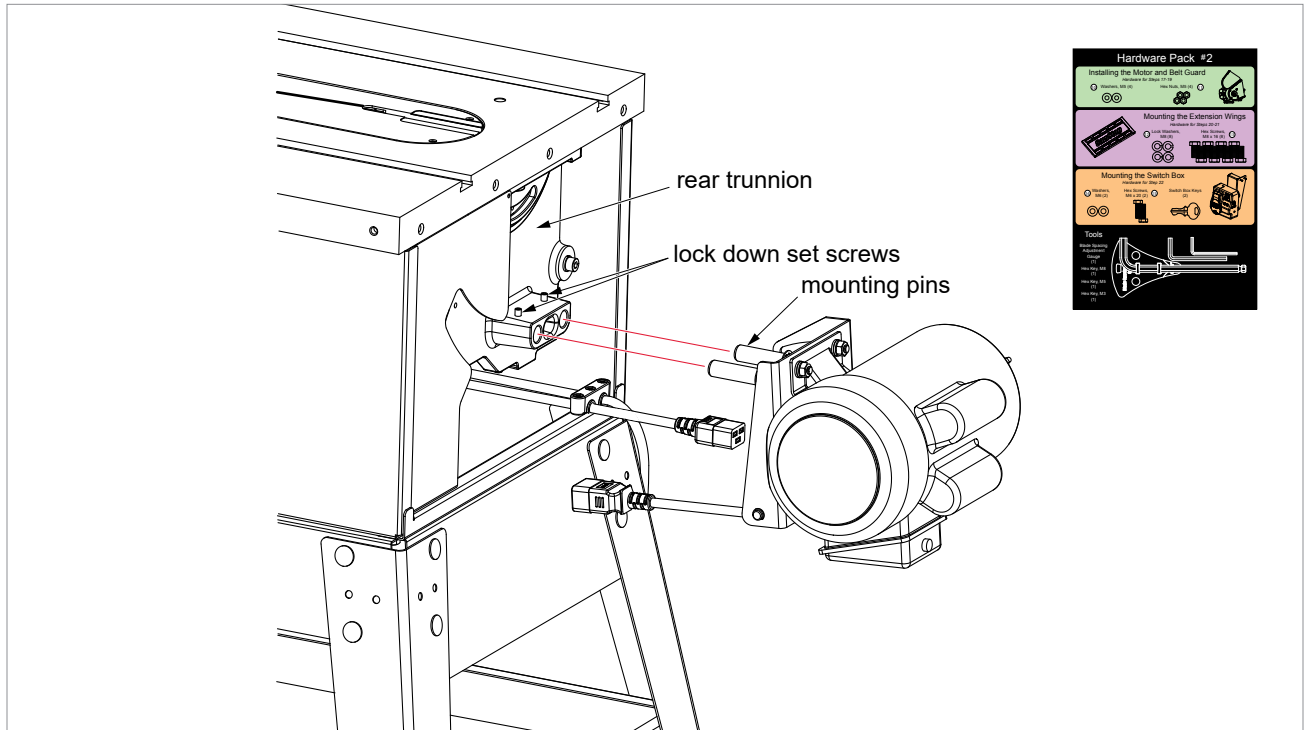

18. Align the four holes in the belt guard with the four screws on the pulley side of the motor. Use four M5 washers and four M5 hex nuts from the hardware pack to mount the belt guard to the pulley side of the motor (see Fig. 20). Use an 8 mm socket to tighten the hex nuts.

Fig. 20

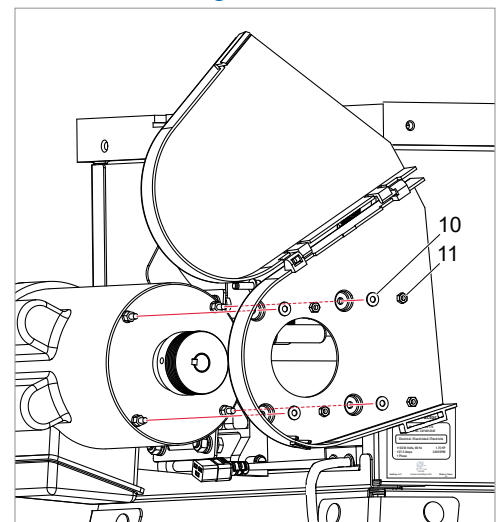

ASSEMBLING YOUR SAW

19. Install the motor belt by first placing the belt over the arbor pulley and then lifting the motor upward and placing the other end of the belt over the motor pulley (see Fig. 21). Release the motor when the belt is in place so that the weight of the motor puts tension on the belt. Rotate the belt by hand to make sure the ribs on the belt are aligned with the grooves on both pulleys (see Fig. 22).

Note: The tilt angle of the saw can be increased to provide more access to the arbor pulley.

Connect the short electrical cord extending from the rear of the cabinet to the matching plug extending from the motor. Make sure the plugs are connected below the motor.

Fig. 21

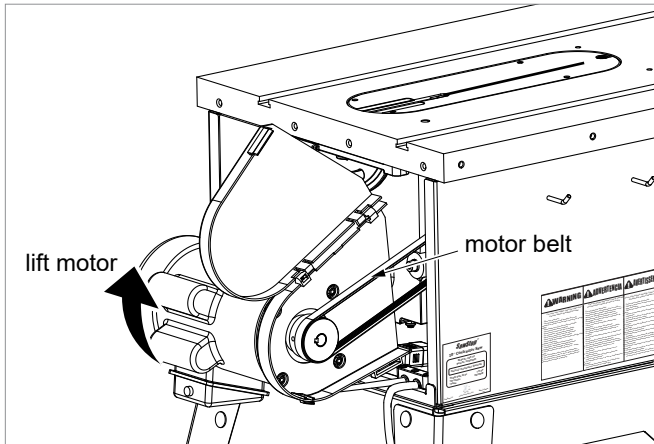
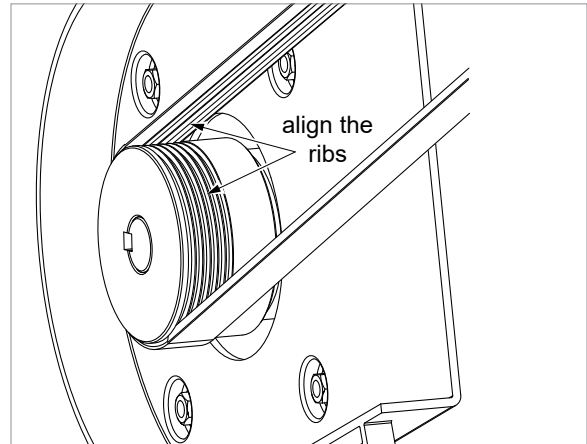

Fig. 22



Mounting the Extension Wings

20. The hardware required to mount the extension wings to the cast iron table top is located in the area with the purple background on hardware pack #2. Position one of the extension wings next to the left side of the cast iron table and align the holes in the side of the wing with the four threaded holes on the side of the table (see Fig. 23). It doesn't matter which direction the SawStop lettering on the top of the extension wing faces. Mount the left extension wing with four M8 lock washers and four M8 x 16 hex screws, but do not tighten. Repeat the same procedure to mount the other extension wing to the right side of the table.

Note: Cast iron extension wings are available from SawStop as an upgrade (see page 85).

Fig. 23

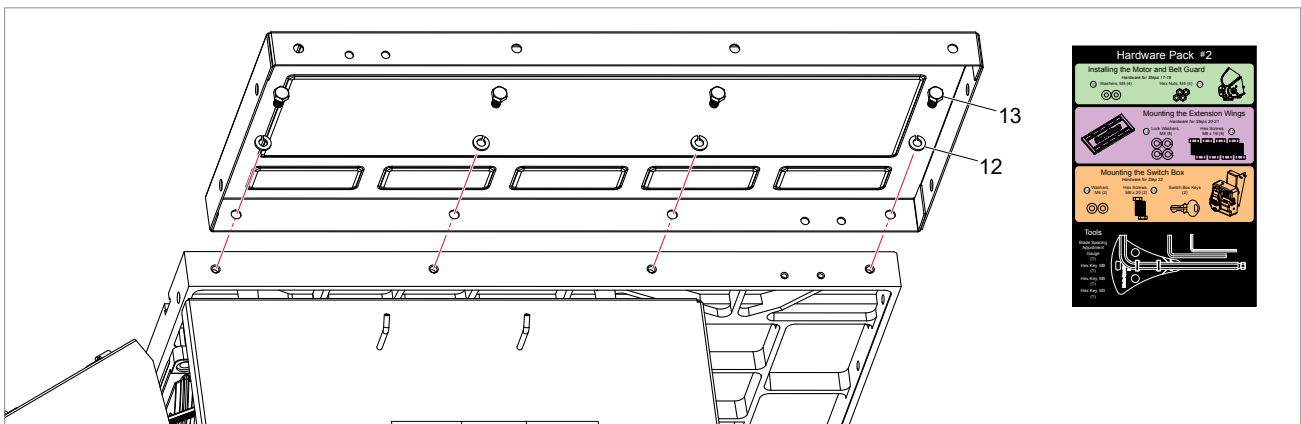

ASSEMBLING YOUR SAW

21. Use a straight-edge to level the extension wings with the cast iron table top and tighten all of the M8 x 16 hex screws with a 13 mm wrench (see Fig. 24).

Fig. 24

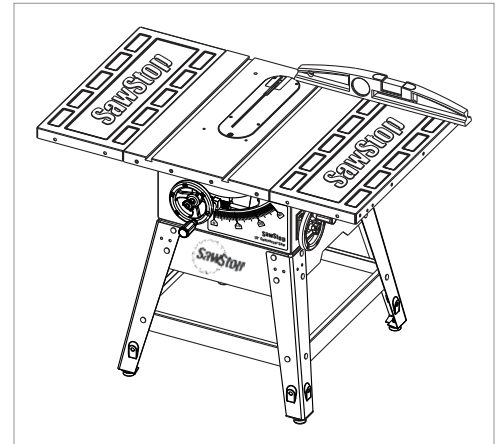

Mounting the Switch Box

22. The hardware required to mount the switch box to the cast iron table top is located in the area with the orange background on hardware pack #2. Use two M6 washers and two M6 x 20 hex screws to mount the switch box under the left extension wing (see Fig. 25). Tighten the screws with a 10 mm wrench.

Fig. 25

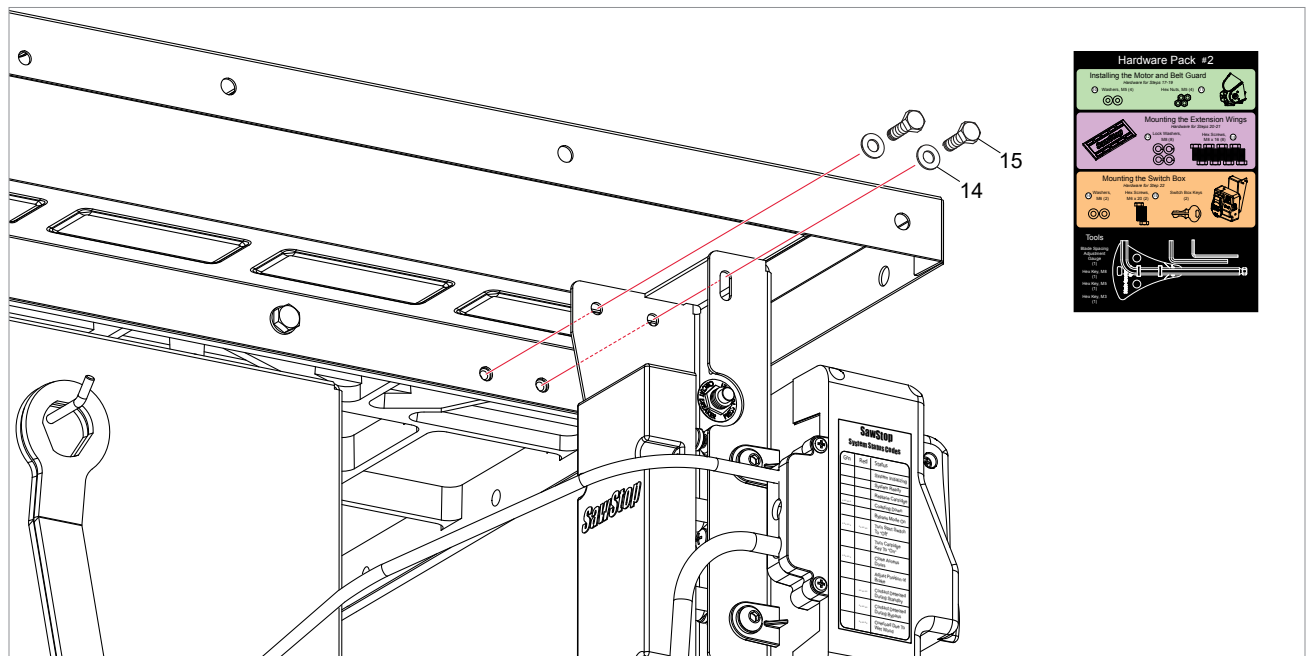

CONGRATULATIONS, YOUR SAW IS NOW ASSEMBLED.

Note: You must install a rip fence prior to using the saw. Refer to the manual accompanying your rip fence for instructions on how to install the fence.

GET TO KNOW YOUR SAW

The major components of your saw are identified below. Make sure you can identify these components in order to follow the instructions in this manual.

Fig. 26

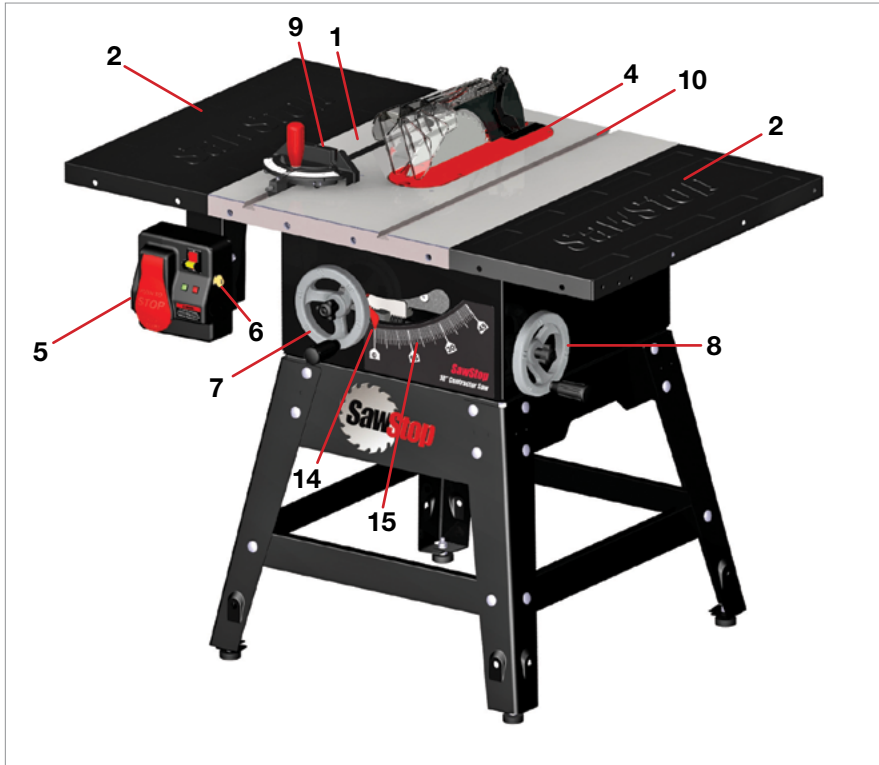

External Components

1. Table Top
2. Extension Wings
3. Blade Guard Assembly
4. Standard Table Insert
5. Switch Box
6. Bypass Key
7. Elevation Hand-wheel
8. Tilt Hand-wheel
9. Miter Gauge
10. Miter Gauge Slots
11. Spreader / Riving Knife Storage Pins (2)
12. Blade Wrenches (2)
13. Riving Knife
14. Tilt Angle Indicator
15. Tilt Angle Scale
16. Stand
17. Thermal Overload Switch
18. Push Stick

Fig. 27



GET TO KNOW YOUR SAW

Fig. 28

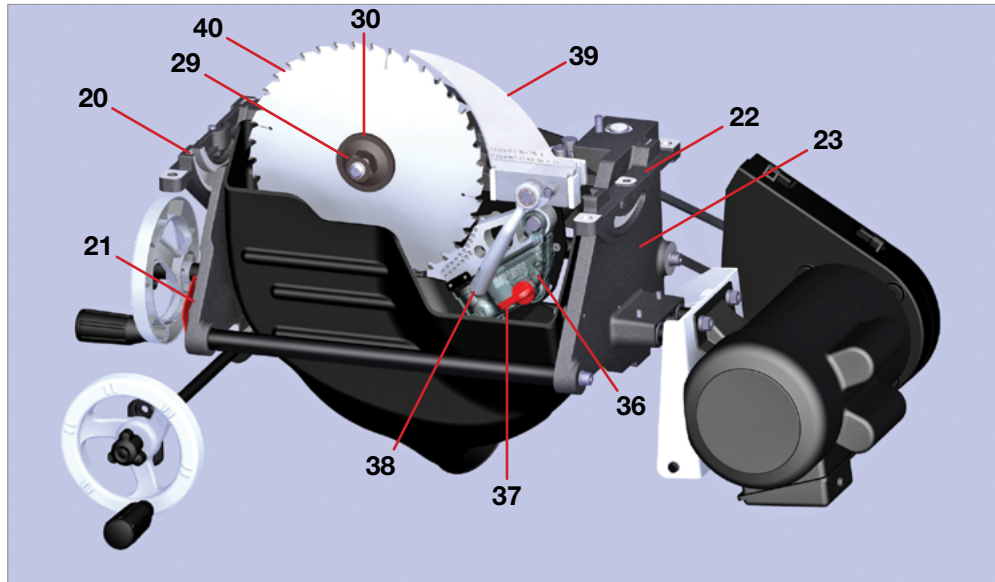

Internal Components

- | | | |
|----------------------------|--------------------------------|--------------------------------|
| 20. Front Trunnion Bracket | 27. Belt Guard | 34. Lower Elevation Limit Stop |
| 21. Front Trunnion | 28. Arbor Block | 35. Brake Positioning Bolt |
| 22. Rear Trunnion Bracket | 29. Arbor Nut | 36. Brake Cartridge |
| 23. Rear Trunnion | 30. Arbor Washer | 37. Cartridge Key |
| 24. Elevation Plate | 31. Dust Shroud | 38. Quick-Release Clamp Handle |
| 25. Motor | 32. Dust Port | 39. Riving Knife |
| 26. Motor Belt | 33. Upper Elevation Limit Stop | 40. Saw Blade |

Fig. 29

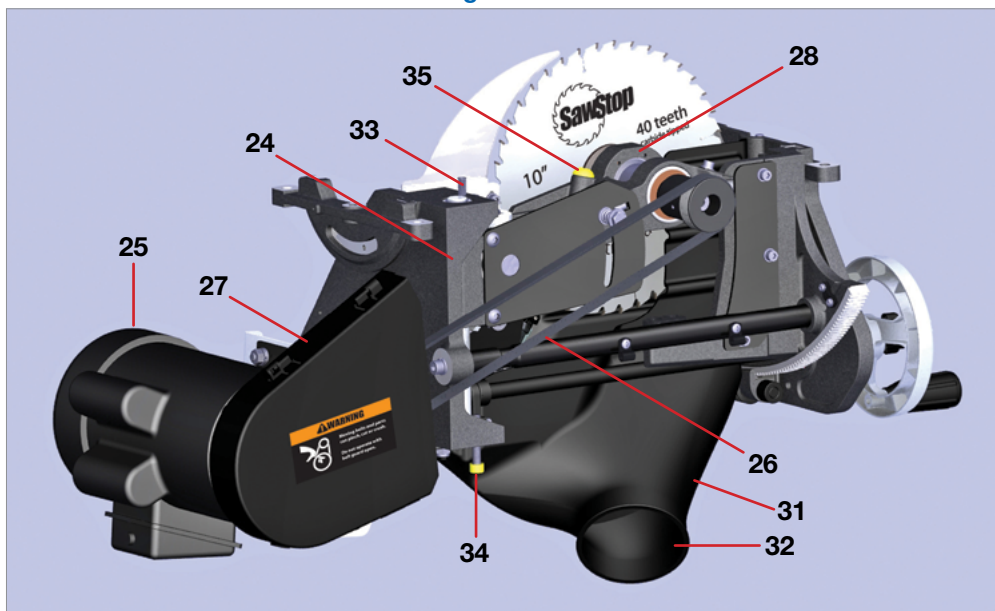

PREPARING YOUR SAW FOR USE

Saw Placement

Position the saw on a level surface away from sources of moisture and electrical noise. Make sure there is sufficient room to allow free access to all sides of the saw.

Table Insert Removal and Installation

Your saw is shipped with a high-quality, zero-clearance table insert. The insert is factory-adjusted to fit securely in the table opening and below the table surface. If you wish to perform additional adjustment on the insert, [see page 67](#) for instructions.

WARNING! Always turn off the main power switch and unplug the power cord before removing or installing the table insert on your saw.

The rear of the table insert is held in place by two lock down screws in the bottom rear of the insert and two lock down screws in the table opening. It is held down in the front by latches formed at the ends of a rotating lock-down lever. The lock-down lever allows you to easily remove the insert without the use of tools.

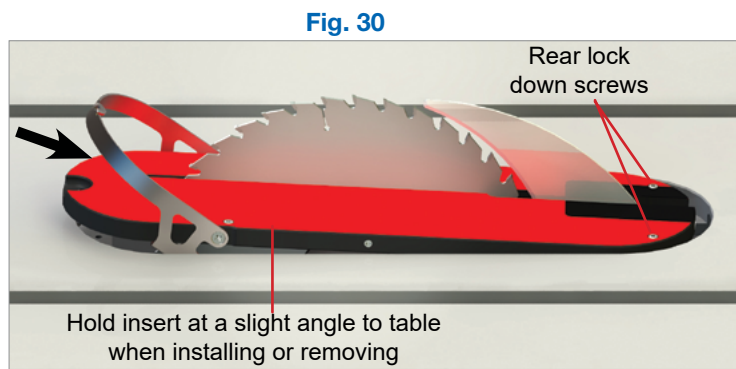

To install the table insert, hold it at a slight angle, with the lock-down lever rotated upwards and the rear of the insert lower than the front (see Fig. 30). Slide the rear of the insert around the spreader or riving knife and against the back of the table opening so that the heads of the rear lock down screws in the bottom of the insert slide under the heads of the lock down screws in the table opening (see Fig. 31). Then, with the lock-down lever rotated upwards, lower the front end of the insert into the table opening until the insert lies flat. Finally, rotate the lock-down lever all the way down so that it fits along the edge of the table insert. Be certain that no part of the table insert extends up beyond the table surface; it should be flush or just below the table surface.

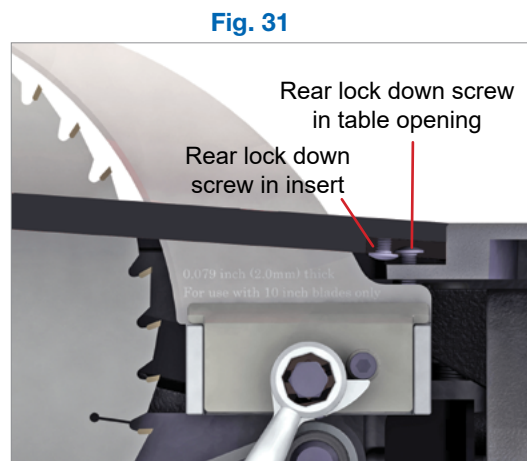

Do not attempt to make a dado cut through the standard table insert because the dado set will hit the steel frame on the inside of the insert and activate the brake cartridge. There is an optional zero-clearance table insert accessory specifically designed for dado cuts (see page 85).

WARNING! Never operate the saw without the table insert in place.

CAUTION! Do not use table inserts with metal or other electrically-conductive parts that could contact the blade. This can cause the brake to be activated unnecessarily.

PREPARING YOUR SAW FOR USE

Blade or Dado Installation

The SawStop® Contractor Saw is designed to be used with a 10 inch saw blade or an 8 inch dado set. A dado set is made up of two circular saw blades on either side of a set of removable knives or chippers. You can use a dado set to cut a groove or slot in a workpiece. Other sizes or types of blades are not compatible with a SawStop saw. If you attempt to use an incompatible blade, the safety system will display an error code and prevent the motor from starting.

WARNING! Always turn off the main power switch and unplug the power cord before removing or installing a blade or dado set on your saw.

WARNING! Only install 10 inch blades or 8 inch dado sets (with optional dado cartridge and optional dado table insert). Do not install other size blades or dado sets. Do not install molding heads or other non-standard cutters. Use of these non-standard blades or cutters may cause serious injury.

The Contractor Saw comes with a 40 tooth, 10 inch combination saw blade. The blade may be lightly coated in oil to prevent rusting. Clean the blade thoroughly before you use it for the first time. If you wish to install a different blade, use a high quality blade that does not have anti-rust coatings on the teeth (e.g., lacquer, wax, etc.). Such coatings can interfere with (or potentially defeat) the ability of the system to detect contact. Blades with depth-limiting shoulders may take longer to stop in the event of an accident than standard blades, and you could receive a more serious injury. Therefore, SawStop recommends using blades without depth-limiting shoulders.

The SawStop safety system is designed for use with standard 10 inch blades with kerfs from 3/32 inch to 3/16 inch. Blades with kerfs much thinner than 3/32 inch should not be used because those blades might not be strong enough to withstand the force applied by the brake when it activates. As a result, those blades might deform and stop more slowly in the event of an accident, resulting in a more serious injury. Blades with kerfs much thicker than 3/16 inch are heavier than standard 1/8 inch kerf blades. Therefore, those blades should not be used because they may stop more slowly than standard blades in the event of an accident, resulting in a more serious injury.

To install the blade or dado set, use the open end of one of the blade wrenches included with the saw to hold the arbor behind the arbor flange, and use the closed end of the other blade wrench to loosen the arbor nut (see Fig. 32). The arbor nut is right-hand threaded so turn the nut counter-clockwise to loosen it and clockwise to tighten it. After removing the arbor nut and arbor washer, install the blade or dado set and reinstall the arbor washer and arbor nut. The saw is designed for use with 8 inch dado sets up to 29/32 inch wide. For dado widths larger than about 3/8 inch, do not use the arbor washer. Instead, tighten the arbor nut directly against the dado set. Use the blade wrenches to tighten the arbor nut securely.

If you install a dado set, you will also need to install an optional dado brake cartridge and an optional dado table insert (see page 57 and page 85). A dado set cannot be used with the standard SawStop® brake cartridge or table insert.

Fig. 32

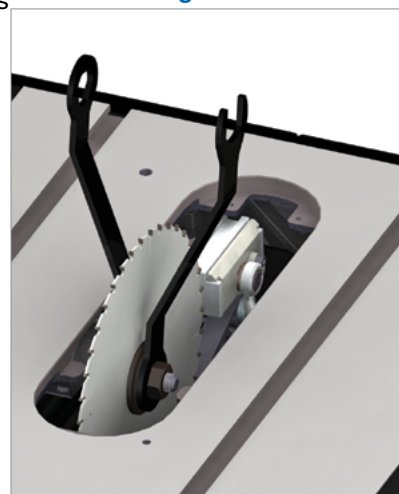

WARNING! Do not attempt to use saw blades made of materials that are electrically non-conductive (e.g., abrasive blades, blades with plastic hubs, etc.). The SawStop® safety system will not allow the saw to operate if these blades are installed.

WARNING! Never install the blade backwards. The brake might not stop a blade that is installed backwards and you may receive a serious injury.

PREPARING YOUR SAW FOR USE

Brake Position Adjustment

It is important to accurately adjust the spacing between the brake cartridge and the blade (see Fig. 33). If the brake is too far from the blade, the safety system will take longer than necessary to stop the blade. On the other hand, if the brake is too close to the blade, a portion of the blade might contact the brake and cause it to activate.

WARNING! Always turn off the main power switch and unplug the power cord before removing, installing or adjusting the brake cartridge on your saw.

The exact diameters of 10 inch blades will vary. In addition, blades that have been resharpened one or more times will usually be under 10 inches. Therefore, always check the spacing between the blade and the brake when installing a different blade or brake cartridge.

Fig. 33

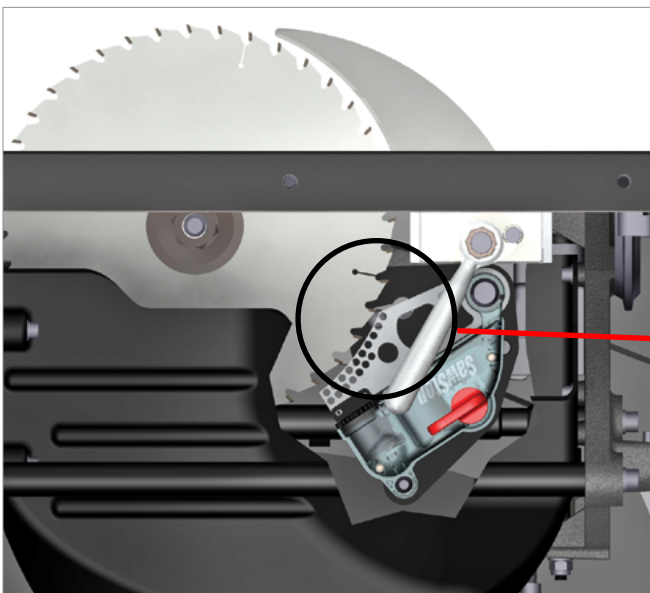
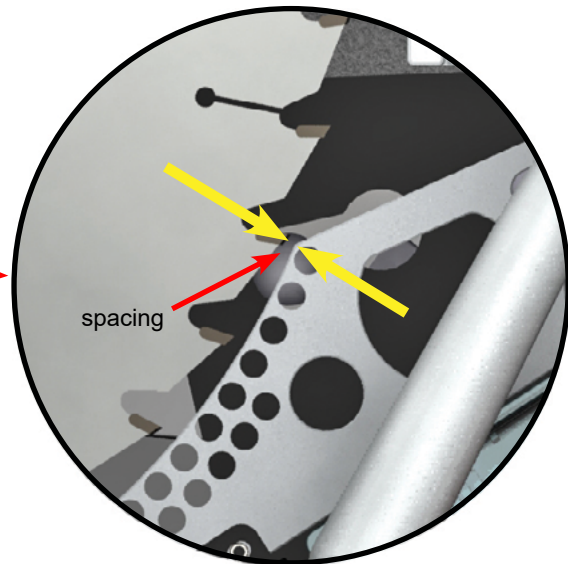

Fig. 34



The spacing between the brake cartridge and the blade is adjusted by the yellow brake positioning bolt mounted in the top of the arbor block (see Fig. 35). To access the brake positioning bolt, set the tilt angle to 0° and adjust the blade elevation to approximately 1 1/2 inches above the table top. The bolt will be accessible through the opening in the table top.

Using the 8 mm hex key included with the saw, turn the brake positioning bolt clockwise to decrease the spacing between the brake cartridge and the edge of the blade, or counter-clockwise to increase the spacing. Adjust the brake position as needed to set the spacing between the teeth of the blade and the closest point on the brake cartridge to between 1/16 and 3/32 inch (see Fig. 34).

Fig. 35

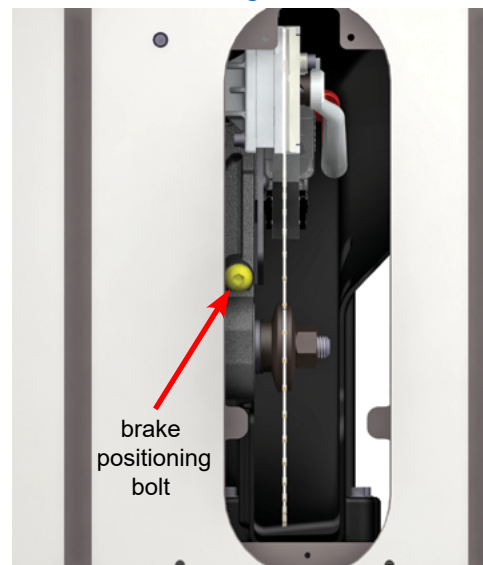

PREPARING YOUR SAW FOR USE

A blade spacing adjustment gauge is included with the tools on hardware pack #2 and can be placed between the closest points on the blade and brake cartridge to set the appropriate spacing (see Fig. 36). The two slots on the blade spacing adjustment gauge can be used to store the 8 mm hex key that is used to adjust the brake position. The blade spacing adjustment gauge also contains magnets so it can be attached to the side of the Contractor Saw housing.

Alternatively, you can place a U.S. nickel between the brake cartridge and the edge of the blade to set the correct spacing.

Fig. 36

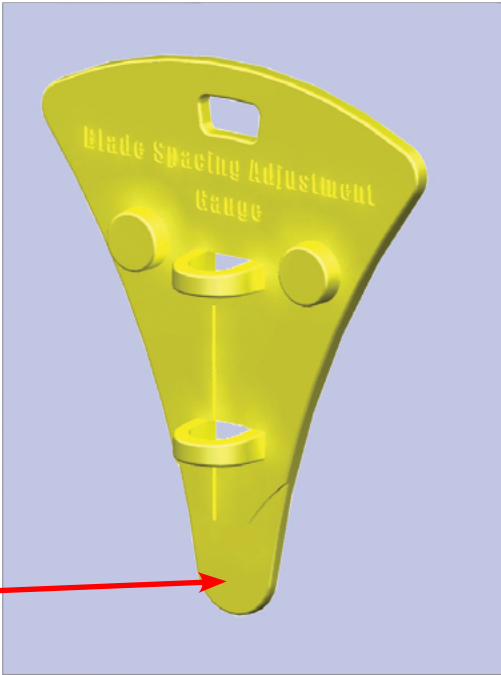

use the tip of the blade spacing adjustment gauge to set the correct spacing between the blade and the brake

After adjusting the brake position and before starting the saw, spin the blade by hand at least one full revolution to verify that the blade does not hit the brake (see Fig. 37).

Fig. 37

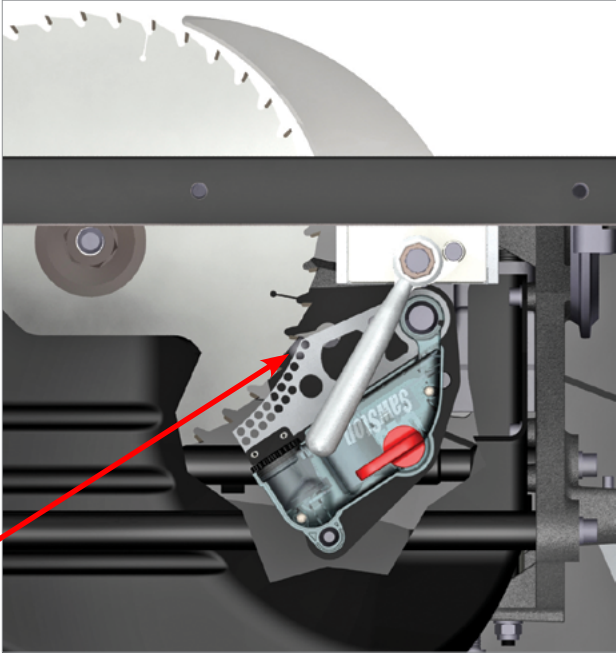

spin the blade by hand to make sure the blade does not touch the brake

PREPARING YOUR SAW FOR USE

Blade Guard and Riving Knife Installation

Your SawStop® saw includes a unique, quick-release blade guard mounting system. This mounting system was developed to allow you to quickly remove and install the blade guard and riving knife without the use of tools and without the need for realignment. The mounting system is factory-aligned to the arbor flange and should not require adjustment. If you wish to change the alignment, [see page 69](#) for instructions.

The saw is shipped with the riving knife installed. The riving knife is an extremely important tool for reducing the potential for kickback when the blade guard cannot be used. The riving knife should always be used whenever you need to make rabbet or other non-through cuts (where the blade does not cut through the top of the wood) and narrow cuts where the guard would interfere with the rip fence.

Fig. 38

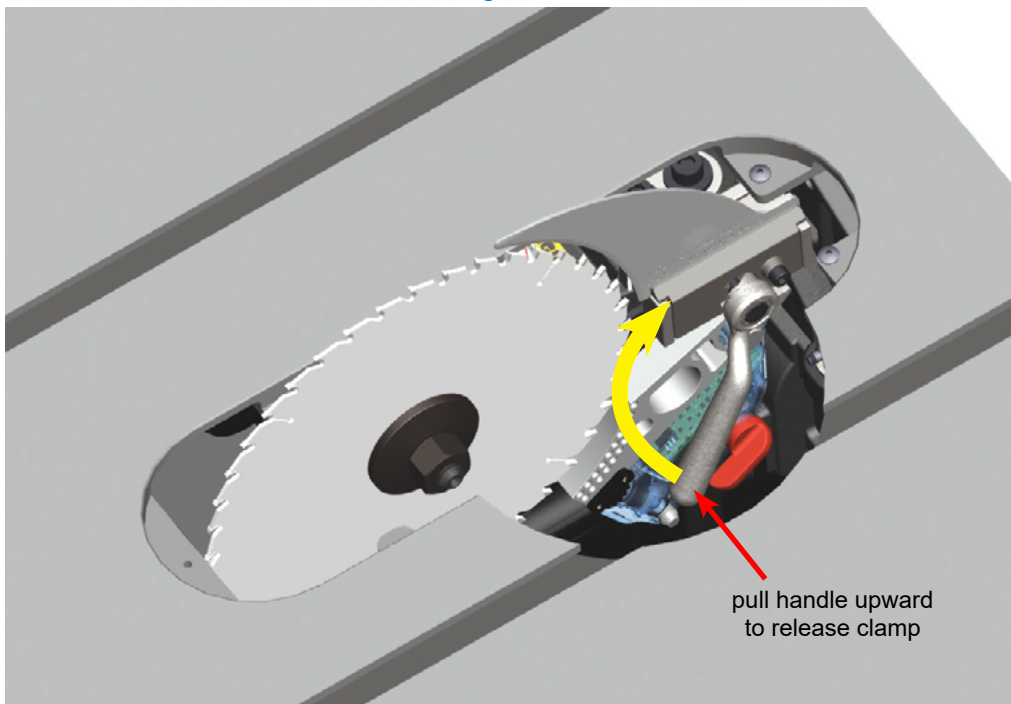

WARNING! Always turn off the main power switch and unplug the power cord before removing or installing the blade guard or riving knife on your saw.

For the majority of cuts, the blade guard should be used. To install the blade guard, first remove the riving knife by lifting the clamping handle fully upward until the clamping plate moves away from the riving knife ([see Fig. 38](#)). Then move the riving knife slightly toward the right to clear the positioning pins, and lift it out of the clamp.

WARNING! Use the blade guard and spreader for every operation for which it can be used, including all through-sawing.

PREPARING YOUR SAW FOR USE

To install the blade guard, position the spreader in the clamp and flat against the base plate. The positioning pins will align the spreader in the correct position. Lower the clamping handle completely to lock the spreader in place (see Fig. 39). If the clamping handle is difficult to lower, make sure the spreader is positioned flat against the base plate.

Fig. 39

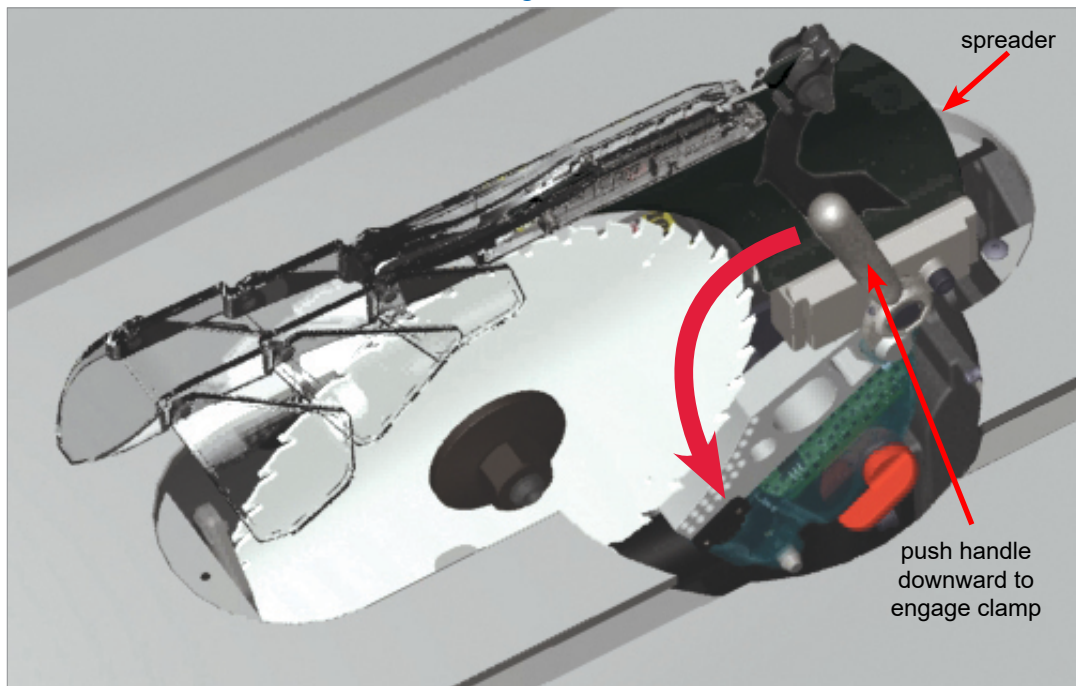

To remove the guard, use the same procedure as removing the riving knife. Similarly, to install the riving knife, use the same procedure as installing the guard.

The clamping force used to hold the spreader and riving knife in place can be increased if the spreader and riving knife are not held securely, or decreased if too much force is required to lower the clamping handle. See page 72 for instructions on adjusting the clamping force.

See page 47 and page 49 for instructions on the operation and use of the blade guard and the riving knife.

Note: when using a dado set, neither the blade guard nor the riving knife may be used. Instead, use other protective devices such as push sticks, push blocks and featherboards (see page 54; see Fig. 106, Fig. 108 and Fig. 109).

PREPARING YOUR SAW FOR USE

Dust Collection

Your SawStop® saw includes a dust shroud around the blade to provide better dust collection than ordinary contractor saws (see Fig. 28). Connect a suitable dust collection system to the dust port on the bottom of the dust shroud and always use the dust collection system when making a cut.

SawStop recommends the use of a dust collection system that provides at least 350 CFM of flow at the dust port. Attach a 4 inch diameter flexible hose between the inlet port on your dust collector and the port on the dust shroud (see Fig. 40). Use hose clamps to secure the hose to the port on the dust shroud. If you power your dust collector and SawStop® saw from the same electrical circuit, ensure the circuit and breaker have sufficient capacity for both machines.

For more information on dust control and installing a dust collection system, see **Woodshop Dust Control**, by Sandor Nagyszalanczy, Taunton Press, 2002.

Fig. 40

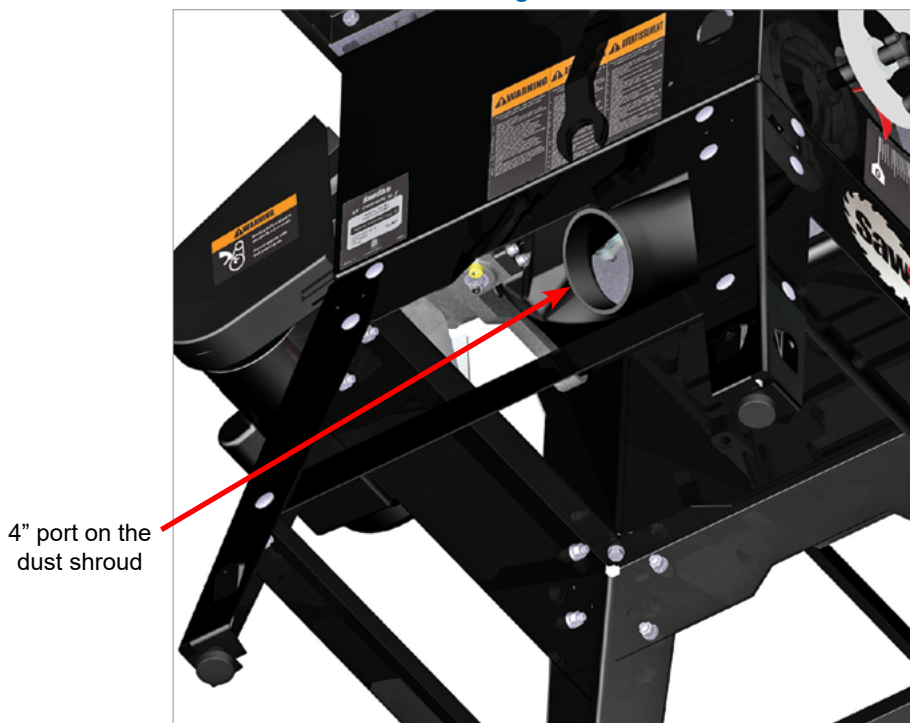

4" port on the
dust shroud

WARNING! Do not remove the dust shroud because the blade will be exposed. If you contact the blade under the table, the blade may retract toward you and cause a severe injury.

WARNING! Some types of dust created by sawing, power sanding, grinding, drilling, and other construction activities contain chemicals known to cause cancer, birth defects or other reproductive toxicity or harm. Some examples of these chemicals are lead from lead-based paints, crystalline silica from bricks, cement, and other masonry products, and arsenic and chromium from chemically treated lumber. In addition, wood dust has been listed as a known human carcinogen by the U.S. government. The risk from exposure to these chemicals and to dust varies depending on how often you do this type of work. To reduce your exposure, work in a well ventilated area and work with approved safety equipment including dust masks or respirators designed to filter out such dust and chemicals.

PREPARING YOUR SAW FOR USE

Electrical Power Connection

WARNING! Do not connect the saw to electrical power until the saw is completely assembled and you have read and understood this entire manual.

The A-C motor that comes with your saw is rated at 1.75 hp and operates at 60 Hz. It can be used with 110-120V or 208-240V power. It comes from the factory pre-wired for 115V, which means it will work with 110-120V power. Instructions to re-wire the saw for 208-240V power can be found [on page 36](#). If you plan on re-wiring the saw for 208-240V power you must purchase a 230V contactor box assembly (CNS-WA-014), because the contactor box assembly that comes with your saw is only rated for 110-120V power.

The motor draws 14 amps when it is wired for 110-120V power, and 7 amps when it is wired for 208-240V power. Do not use any other motor to power your saw. Connect the saw to an electrical circuit that is protected by a 20 amp breaker.

Note: The A-C motor that comes with Contractor Saw model CNS175-AU (sold in Australia) is pre-wired for 208-240V power and operates at 50 Hz. The contactor box assembly that comes with CNS175-AU is designed for 240V / 50Hz power.

If you use an extension cord to supply power to your saw, use only extension cords that have three-prongs (including one grounded prong). Also, the extension cord must be heavy enough to carry enough current for the motor. An extension cord that is undersized or too long can cause a voltage drop that will decrease the power supplied to the motor and could result in overheating. See Table 1 for the minimum recommended extension cord length and gauge for 110-120V power. For best performance, use the shortest and heaviest (lowest numbered) extension cord gauge possible.

Minimum Extension Cord Gauge for 110-120V	
Length	Gauge
0 - 25 Feet	12 AWG
25 - 50 Feet	10 AWG
over 50 Feet	Not Recommended

Table 1

Attempting to operate the saw with power other than 110-120V, or 208-240V if the motor is re-wired, will void all warranties and may result in serious injury as well as damage to, or a malfunction of, the saw or safety system.

Fig. 41

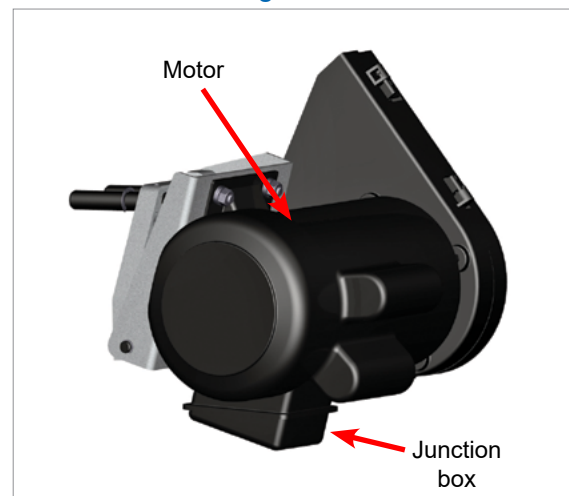

WARNING! This saw must be connected to a grounded wiring system, or to a system having an equipment-grounding conductor. Failure to connect this saw to an adequate electrical ground may cause the safety system to malfunction and could result in a serious injury or electric shock.

PREPARING YOUR SAW FOR USE

Re-Wiring the Saw for 208-240V Power

Before you re-wire the motor for 208-240V power you must first install a 230V contactor box assembly (CNS-WA-014). The contactor box assembly that comes with your saw is only rated for 110-120V power and it is not compatible with the motor in the 208-240V configuration. To use 208-240V power, you must purchase a SawStop 230V contactor box assembly.

Only after the 230V contactor box assembly has been installed on your saw should you begin re-wiring the motor. The motor that came with your saw is pre-wired for 110-120V power. The following procedure describes how to re-wire the motor for 208-240V power.

- There are two cords that extend out from the back of the saw cabinet: a long cord with a 110-120V male plug to connect to a power outlet, and a short cord with a female plug to connect to the motor. Unplug both cords so the saw is disconnected from power and from the motor.
- Remove the motor belt by opening the belt guard and lifting the motor upward to release tension in the belt.
- Remove the motor from the saw by loosening the two lock down set screws that hold the motor in place (use the included 3 mm hex key), and then slide the mounting pins out of the corresponding holes in the rear trunnion (see Fig. 19).
- Locate the junction box underneath the motor (see Fig. 44) and remove the cover by loosening the Phillips-head screw.
- Inside the junction box are wires connected by two wire nuts. One wire nut connects two black wires and one white wire. The other wire nut connects red, yellow and white wires. Remove any electrical tape from the two wire nuts and then remove the two wire nuts.
- Re-wire the leads as shown in the 208-240V wiring diagram on page 37. Connect the black wire coming from the power cord to the white wire coming from the motor. Connect the white wire coming from the power cord to the red wire coming from the motor. Finally, connect the black wire coming from the motor to the yellow wire coming from the motor.
- Locate the additional wire nut that is included with the 230V contactor box assembly. Use the three wire nuts to connect the wires and then wrap each wire nut with two layers of new electrical tape.
- Double check the wiring to make sure it matches exactly the 208-240V schematic (see page 37), and then re-attach the junction box cover.
- Reinstall the motor and motor belt (see page 23).
- Plug the male end of the motor cord into the female plug on the matching short cord that extends out from the back of the saw cabinet.
- The 230V contactor box assembly comes with a NEMA 6-15P plug attached to the end of the main power cable. If you need to replace this plug or replace the power cord with a longer one (see page 38).
- Your saw is now ready to use with 208-240V power.

PREPARING YOUR SAW FOR USE

Electrical Schematic

Fig. 42

110-120V Wiring Diagram

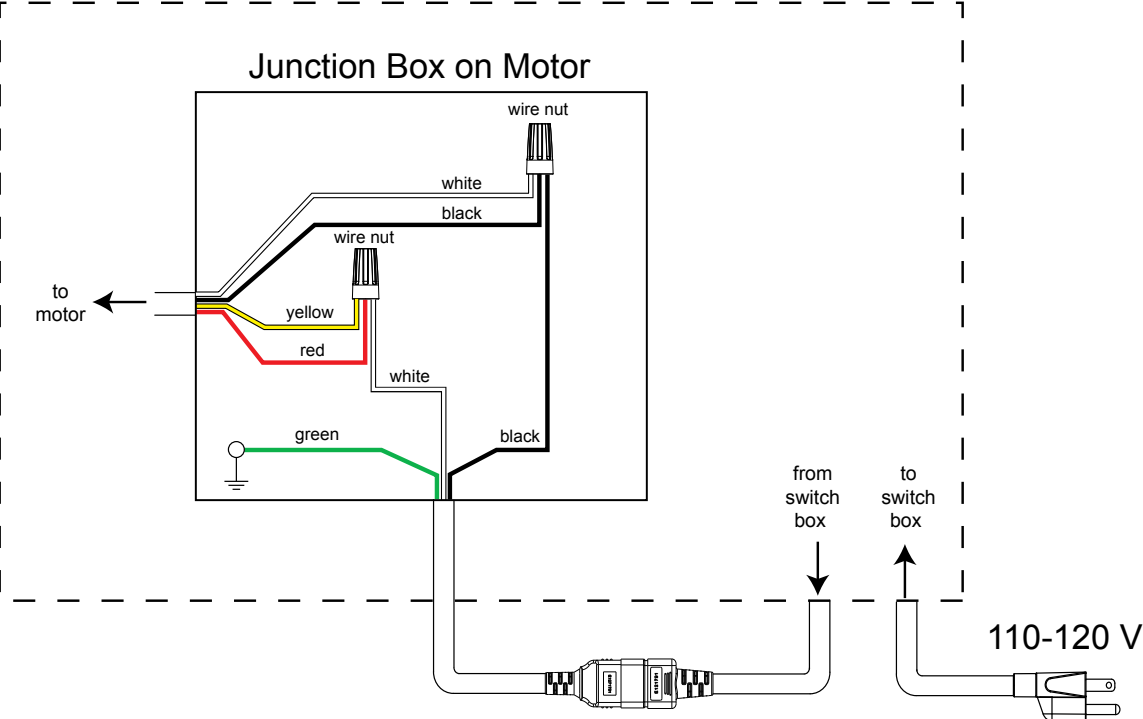

208-240V Wiring Diagram

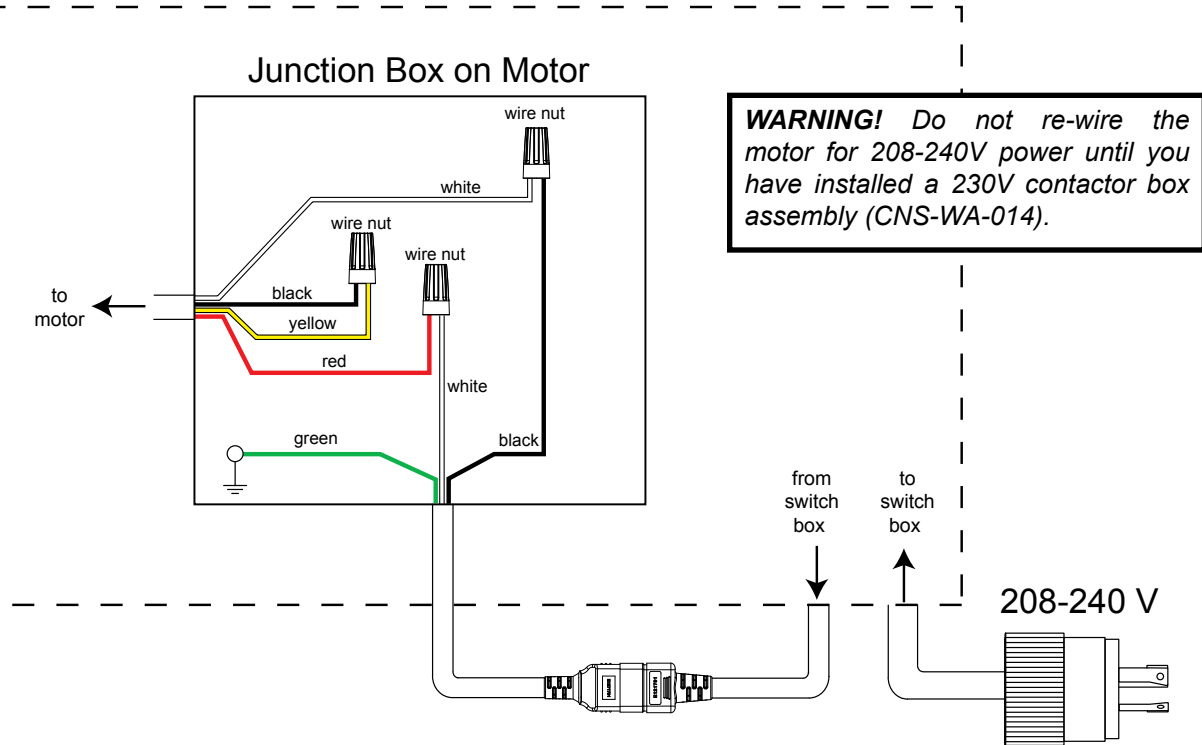

WARNING! Do not re-wire the motor for 208-240V power until you have installed a 230V contactor box assembly (CNS-WA-014).

Preparing Your Saw

PREPARING YOUR SAW FOR USE

Changing the Plug or Power Cord on a 208-240V Saw

Replacing the Power Cord Plug

The 230V contactor box assembly (CNS-WA-014) which enables the Contractor Saw to be used with 230V power comes with a NEMA 6-15P plug attached to the end of a 9 ft power cord. If you need to replace the plug with a different style plug, replace it with a 3-prong, 208-240V, UL-listed plug. There are numerous styles of 208-240V plugs, so select a plug that matches the single phase 208-240V power outlet from which you intend to power the saw. Connect the white and black wires to the two “hot” plug terminals. Connect the green wire to the ground plug terminal. Follow the manufacturer’s specific wiring instructions that come with your 208-240V plug.

Replacing the 230V Power Cord

You may replace the 9 ft power cord that came attached to your 230V contactor box assembly with a longer cord. If you replace the cord, use a 3-conductor cable heavy enough to carry enough current for the motor. A cord that is undersized or too long can cause a voltage drop that will decrease the power supplied to the motor and could result in overheating. See Table 2 for the minimum recommended cord length and gauge for 208-240V power.

Minimum Cord Gauge for 208-240V	
Length	Gauge
0 - 50 Feet	16 AWG
50 - 100 Feet	14 AWG
100 - 200 Feet	12 AWG

Table 2

Prepare your new power cord by cutting about 6 1/2 inches of the cable housing off of one end of the cord so that you have access to the three insulated wires in the power cord. Strip off the insulation at the tips of each of the three wires and secure terminal forks at the end of the white and black wires and a ring terminal on the green wire (see Fig. 43). Make sure the connections are secure and not loose and that none of the wires are left uninsulated below the terminal fork or ring.

Fig. 43

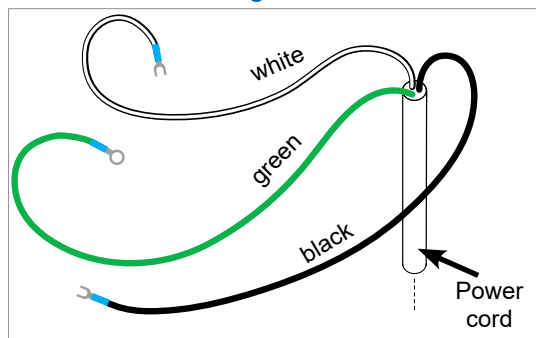

WARNING! Loose electrical connections can cause fires.

WARNING! Make sure the saw is unplugged from the wall outlet before proceeding with the following instructions.

Fig. 44

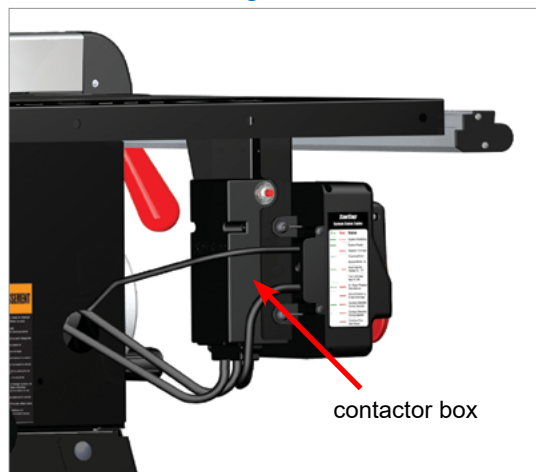

Locate the contactor box which is mounted to the back side of the switch box bracket (see Fig. 44).

PREPARING YOUR SAW FOR USE

With the saw unplugged, use a Phillips screwdriver to remove the four screws on the cover of the contactor box and remove the contactor box cover (see Fig. 45). Locate the contactor to which the black and white wires from the power cord are attached and the ground connection to which the green wire from the power cord is attached (see Fig. 46).

Fig. 45

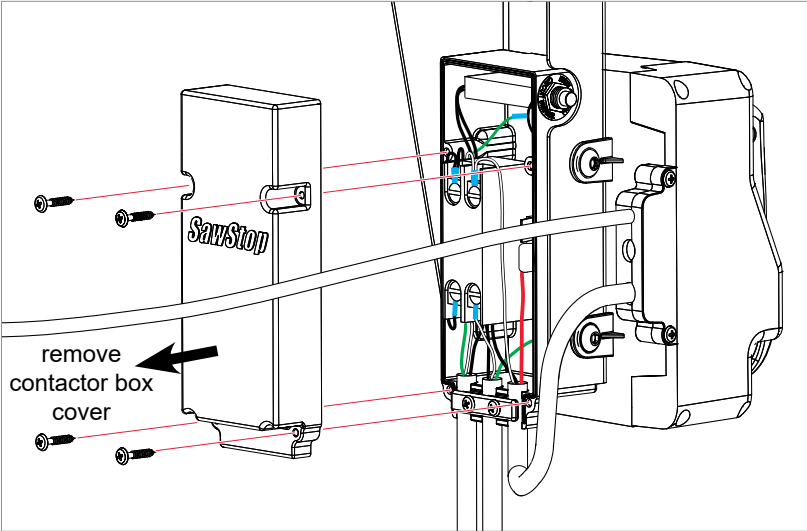

Disconnect the power cord from the contactor box by using a Phillips screwdriver to loosen the two screws at the top of the contactor and removing the ends of the black and white power cord wires from the screws and then removing the end of the green power cord wire from the ground connection (see Fig. 42 and Fig. 43).

Fig. 46

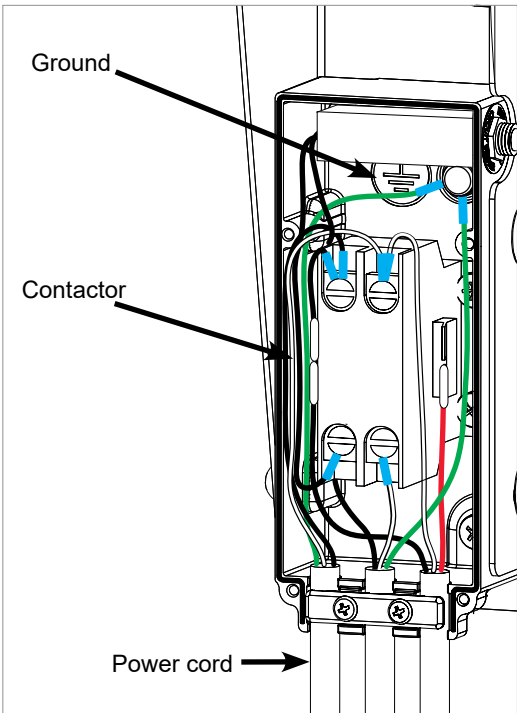
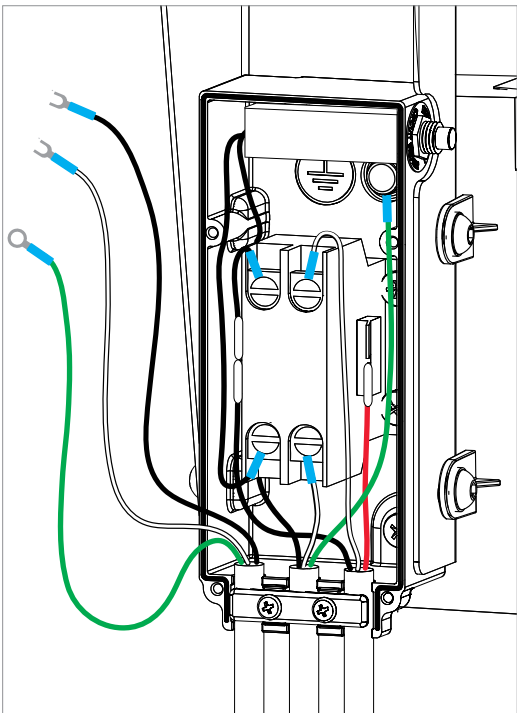
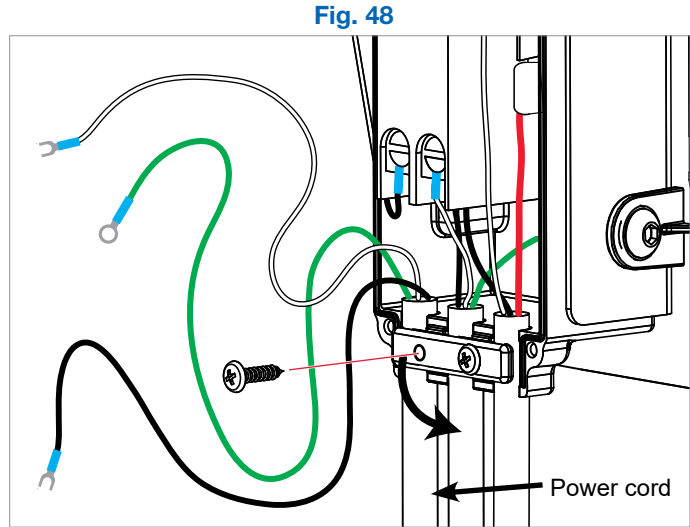

Fig. 47



PREPARING YOUR SAW FOR USE

Using a Phillips screwdriver, remove the left screw that attaches the bar across the cords entering the contactor box and loosen the right screw. Then rotate the bar downwards far enough to remove the power cord (see Fig. 48).



Now install the new power cord in the contactor box. Connect the ground wire (the green wire) to the ground, the white wire to the right, top terminal connection on the contactor, and the black wire to the left, top terminal connection on the contactor (see Fig. 49). A wiring diagram is shown in Fig. 50.

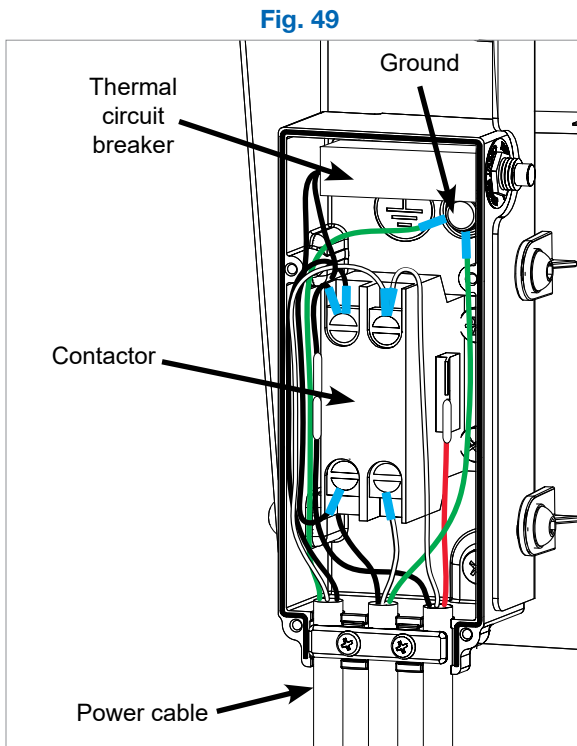

230V Contactor Box Wiring Diagram:

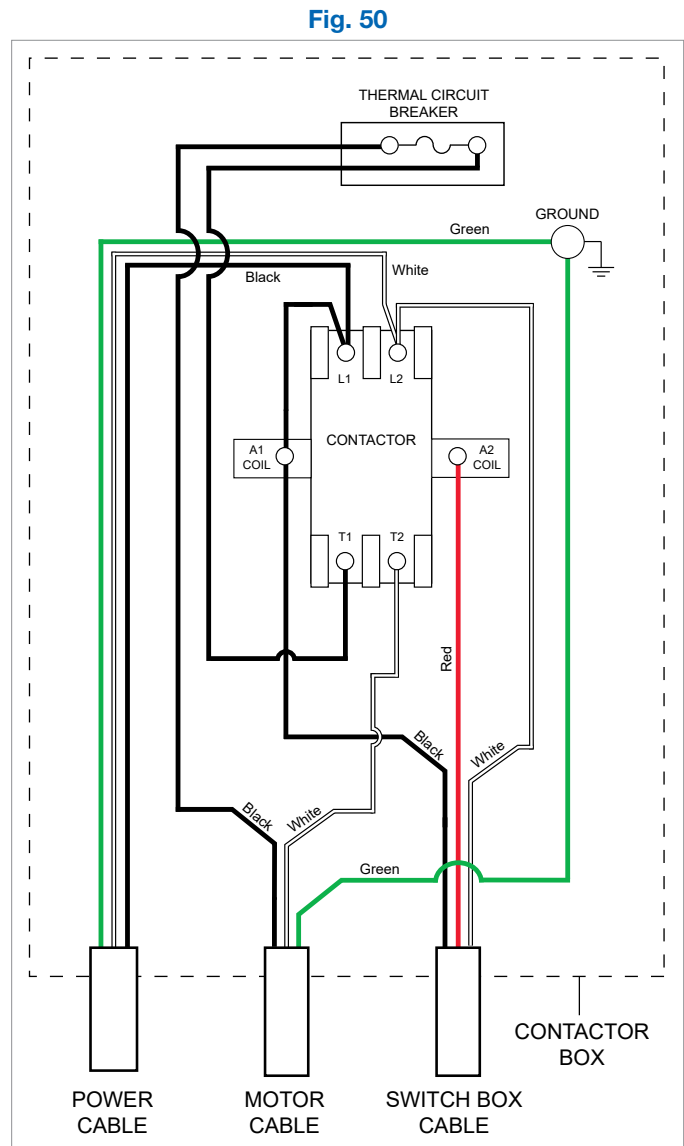

USING YOUR SAW

Adjusting the Blade Height

To maximize safety, the height of the saw blade above the table should be as low as possible while still allowing a complete and precise cut. For through-cuts (i.e., cuts where the wood is cut through its entire thickness), the blade height should be adjusted so that the top of the blade is no more than 1/8 inch to 1/2 inch above the workpiece.

The blade can be adjusted from 1/8 inch below the table top to 3/8 inch above the table top. To adjust the height of the blade, loosen the elevation lock knob and turn the elevation hand-wheel until the blade is at the desired height (see Fig. 51). Turn the hand-wheel clockwise to raise the blade, and counter-clockwise to lower the blade. Lock the blade height by tightening the elevation lock knob.

The saw includes limit stops to prevent the height of the blade from being adjusted past the maximum and minimum setpoints. These limit stops are pre-set at the factory and should not need adjustment. If you decide to adjust the blade elevation limit stops, see page 65 for instructions.

Fig. 51



CAUTION! When adjusting the height or tilt angle of the blade, reverse the hand-wheel slightly to release tension after reaching the limit stops. This prevents any slight twisting of the cast iron assembly that might affect blade alignment.

Adjusting the Blade Tilt Angle

The tilt (bevel) angle of the blade can be adjusted between 0° and 45°. To adjust the tilt angle of the blade, loosen the tilt lock knob and turn the tilt hand-wheel until the blade is at the desired angle (see Fig. 52). The tilt angle of the blade is indicated by the position of the tilt angle indicator on the tilt angle scale. Turn the tilt hand-wheel clockwise to increase the tilt angle, and counter-clockwise to decrease the tilt angle. Lock the tilt angle by tightening the tilt lock knob.

The saw includes limit stops to prevent the tilt angle from being adjusted past the 0° and 45° set points. These limit stops are pre-set at the factory and should not need adjustment. If you decide to adjust the blade tilt limit stops, see page 65 for instructions.

Fig. 52

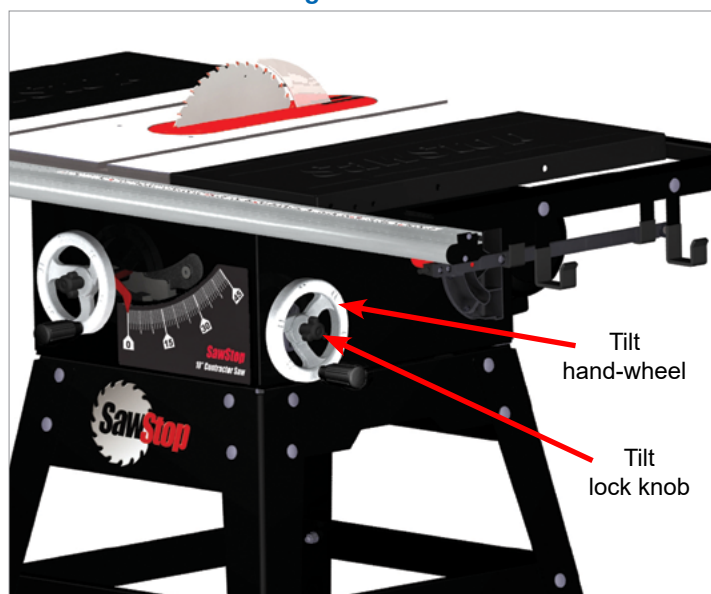

USING YOUR SAW

Turning on the Main Power and Starting the Motor

Your SawStop® saw is equipped with a main power switch to supply power to the SawStop® safety system and a Start/Stop paddle to turn the motor on and off. Both the main power switch and the Start/Stop paddle are mounted on the switch box (see Fig. 53).

WARNING! Never start the saw when the blade is in contact with the workpiece or any other object.

To start your saw, first make sure the Start/Stop paddle is in the “OFF” position (i.e., pushed in) and then turn the main power switch to the “ON” position by flipping the toggle upward. This will turn on power to the SawStop® safety system, and the system will run through a brief initialization routine to test whether the system is operating properly. During this initialization period (approximately 5–10 seconds), red and green lights on the switch box may blink in different patterns as the safety system runs through various self-check steps. These lights are light-emitting diodes (LEDs) and they display the current status of the safety system and saw. Once the safety system completes the initialization routine, the LEDs will display the “READY” status display (green LED on solid, red LED off). The saw is now ready for use.

To start the motor, pull the Start/Stop paddle out. To stop the motor, push the Start/Stop paddle in. The paddle is designed so that it can be pushed in by the operator’s upper leg or knee in an emergency.

If the READY status is not displayed after 15 seconds, the safety system has detected an error that must be corrected before the saw can be used. See page 44 for a key to the LED status codes and an explanation of the error detected for each code. A label describing the LED displays is also positioned on the side of the switch box.

WARNING! Do not unplug or disconnect the saw from electrical power before the blade has stopped spinning. If the power is interrupted while the blade is moving, the safety system will not be active and therefore the brake will not activate in the event of accidental contact. You may receive a serious injury if you contact the spinning blade while the electrical power has been interrupted.

Fig. 53

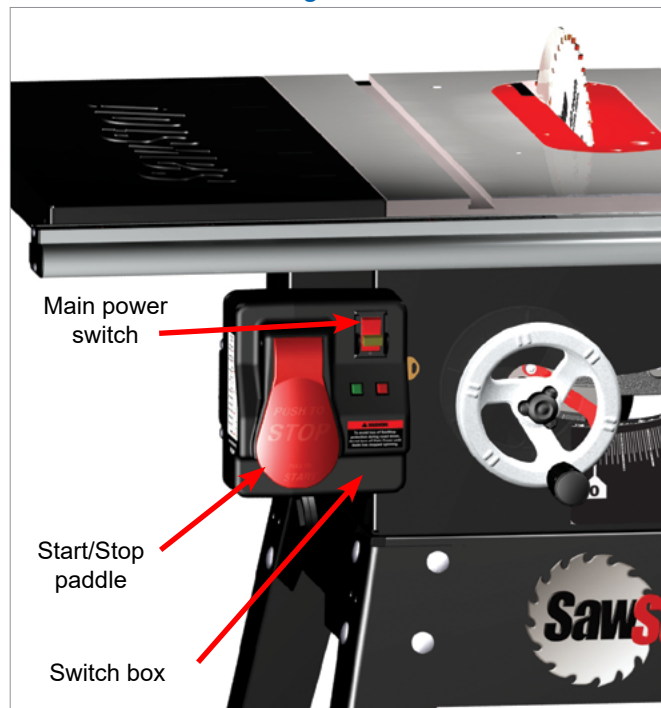

USING YOUR SAW

It is not necessary to turn off the main power switch after pushing in the Start/Stop paddle to turn off the motor. If you plan to make several cuts with the saw, you can leave the main power switch in the ON position between cuts to eliminate the delay due to the initialization routine. Once you have finished using the saw, turn the main power switch to OFF to reduce the likelihood of inadvertent start-up.

In addition, the main power switch has a lockout key that you can remove to prevent children or other non-authorized users from turning the saw on. To remove the key, pull it out, away from the switch (see Fig. 54). To replace the key, press it back into the socket until it snaps into place. When the key is removed, the main power switch can be turned OFF, but it cannot be turned ON.

Fig. 54

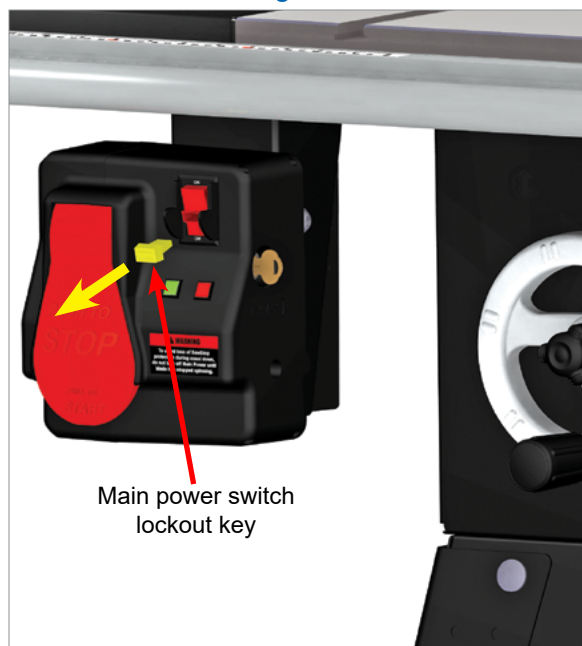
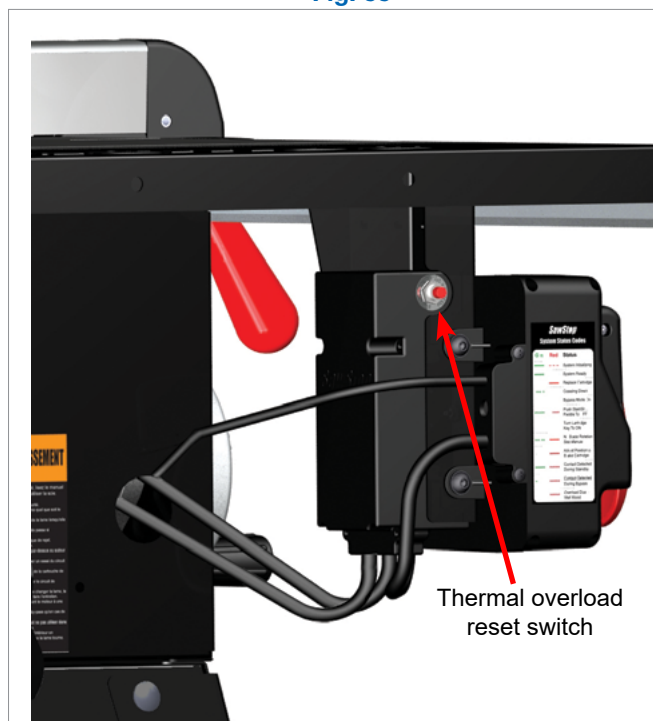

Fig. 55



Your saw also comes equipped with a thermal overload switch that will cut power to the motor if the motor starts to overheat (see Fig. 55). The motor could overheat, for example, if it is overloaded or if a workpiece is fed too rapidly into the blade.

If the thermal overload switch cuts power to the motor, wait a minute or two for the motor to cool down to a safe operating temperature and then push the red thermal overload reset button on the contactor box behind the left side of the switch box. An audible click will indicate that the thermal overload switch has been reset and the saw is ready to use. Double check the electrical circuit and all electrical connections and always use an appropriate feed rate for the material that you are cutting.

USING YOUR SAW

System Status Codes

In the event the safety system detects an error, the LEDs on the switch box will display a status code to indicate what error has been detected. **Fig. 56** shows the different possible status codes which can be displayed. A description of each status code and the necessary corrective action is provided on the following pages.

Fig. 56

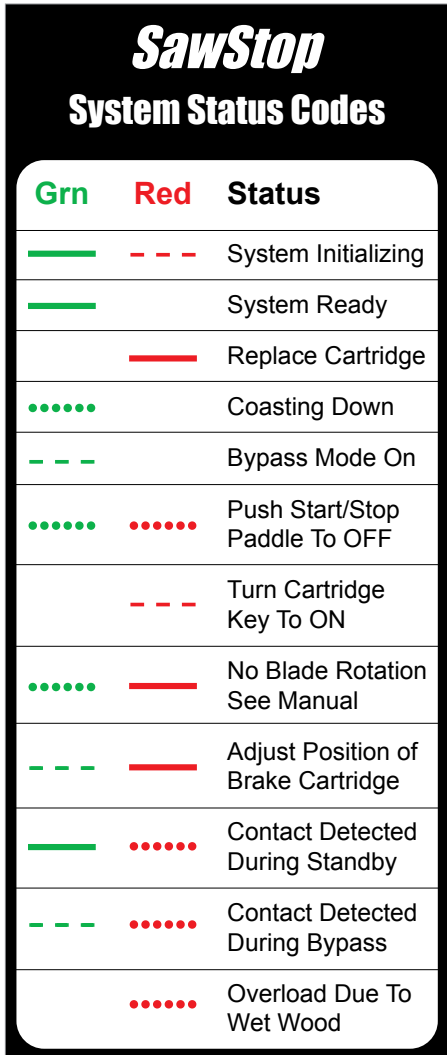

Grn	Red	Status
— — — — —	- - - -	System Initializing
— — — — —		System Ready
	— — — — —	Replace Cartridge
•••••		Coasting Down
- - - -		Bypass Mode On
•••••	•••••	Push Start/Stop Paddle To OFF
	- - - -	Turn Cartridge Key To ON
•••••	— — — — —	No Blade Rotation See Manual
- - - -	— — — — —	Adjust Position of Brake Cartridge
— — — — —	•••••	Contact Detected During Standby
- - - -	•••••	Contact Detected During Bypass
	•••••	Overload Due To Wet Wood

Symbol Key

- ■ ■ ■ ■ Green LED blinks fast
- ■ ■ ■ ■ Green LED blinks slowly
- Green LED is on solid
- ■ ■ ■ ■ Red LED blinks fast
- ■ ■ ■ ■ Red LED blinks slowly
- Red LED is on solid

WARNING! Always turn off the main power switch and unplug the power cord before performing adjustments or maintenance to the saw.

System Initializing — this code indicates that the system is performing self-checks and energizing the brake system to activate in the case of an accident. This condition should clear within 15 seconds after the main power switch is turned on. If the ambient temperature is very low (below about 0° F), this code may take longer to clear. The safety system detects such low temperatures within the brake cartridge. If necessary, the system turns on a heater inside the cartridge to raise the temperature of the electronics. This code will continue until the temperature inside the brake cartridge is within the normal operating range.

System Ready — this code indicates that all self-checks have been completed, the safety system is operating properly, and the saw is in Standby Mode ready to run.

USING YOUR SAW

Replace Cartridge — this code indicates that the brake cartridge has fired or there is some other permanent defect that cannot be corrected. If the cartridge has not been fired, turn off the main power and turn it back on. If the error continues, install a new cartridge.

Coasting Down — this code indicates that the blade is coasting down and that the safety system is ready to activate the brake if contact is detected. The safety system monitors the rotation of the blade while it is coasting down. If you touch the blade while this code is flashing, the brake will activate.

ALWAYS MAKE SURE THE BLADE HAS COME TO A COMPLETE STOP AND THE COAST DOWN STATUS CODE HAS CLEARED BEFORE TOUCHING THE BLADE!

Bypass Mode ON — this code indicates that the saw is running in Bypass Mode and will not activate the brake in the event of accidental contact with the blade. Bypass Mode allows you to cut electrically conductive materials such as aluminum without activating the brake. When the saw is in Bypass Mode, the safety system disables the brake. [See page 55](#) for instructions on how to use the saw in Bypass Mode.

Push the Start/Stop Paddle to OFF — this code indicates that the Start/Stop paddle was in the ON position (i.e., pulled out) before the main power switch was turned on. Push the paddle in to the OFF position to clear this error. This is a safety feature to prevent the saw from restarting after a power loss or after the safety system has turned the saw off due to an error detected during use.

Turn Cartridge Key to ON — this code indicates that the cartridge locking key is not turned to ON. To clear this error first turn the main power switch to OFF, and then make sure the cartridge locking key is correctly installed and turned to ON. [See page 61](#) for instructions on how to install and turn on the cartridge key.

No Blade Rotation — this code indicates that the motor is not able to spin the blade as expected. In most cases this is because the thermal overload switch has cut power to the motor to prevent overheating. If the thermal overload switch cut power to the motor, wait a minute or two for the motor to cool down to a safe operating temperature and then push the red thermal overload reset button on the contactor box behind the left side of the switch box. An audible click will indicate that the thermal overload switch has been reset and the saw is ready to use. This error code may also indicate that the motor is unplugged from the saw, in which case it should be plugged in, or that the motor belt is broken and must be replaced.

Adjust Position of Brake Cartridge — this code indicates that the blade is either too far from or too close to the brake cartridge. To clear this error first turn the main power switch to OFF, and then adjust the position of the brake cartridge as described [on page 30](#). This error code will also be displayed if there is no blade installed, if a blade smaller than 10 inches is installed, or if a non-conductive blade (e.g. abrasive blade) is installed.

Contact Detected During Standby — this code indicates that the safety system detected contact with the blade (or a portion of the arbor) when the blade was not spinning. This code will be displayed if you come into contact with the blade or arbor while the system is in Standby Mode. The brake will not be activated and the code will automatically clear within 5 seconds after contact is ended. The system will not allow the motor to start while this code is displayed.

USING YOUR SAW

Contact Detected During Bypass — this code indicates that contact was detected while the saw was running in Bypass Mode. As described above, the brake will not activate while in Bypass Mode but the safety system will continue to monitor for contact. If this code is displayed, then it indicates that the brake would have activated if the system had not been in Bypass Mode. This error will automatically clear once the blade has finished coasting down.

Material Conductivity Test

The “Contact Detected During Bypass” code also allows you to test a particular material to see if it is too conductive to cut during normal operation. For example, if you have a new material you need to cut and are not sure if it is conductive, you can make several cuts in Bypass Mode. If the “Contact Detected During Bypass” error code is displayed, it means the material is too conductive and must be cut in Bypass Mode to prevent the brake from activating. If the error code is not displayed after several trial runs, then it is likely that the material is not conductive and you can make future cuts in normal mode. (See page 55 for instructions on how to operate the saw in Bypass Mode.)

Overload Due to Wet Wood — this code indicates that the wood being cut is too wet or too green. You can cut most wet or green wood with the safety system active. However, extremely wet or green wood can interfere with the safety system’s ability to detect contact. Accordingly, the system monitors for wet and green wood and, if the wood is too wet or too green, the system will shut off the motor and display this error code. To clear this error, turn the Start/Stop paddle to OFF and turn the main power switch to OFF and then back to ON.

In addition, wet pressure-treated wood may cause an overload error or even cause the brake to activate. The chemicals used to pressure treat wood often contain large amounts of copper, which is conductive. When pressure-treated wood is wet, the combination of copper and water substantially increase the conductivity of the wood. Therefore, allow wet pressure-treated wood to fully dry before cutting. Typically, the wood will be sufficiently dry if left unstacked in a dry location for 24 hours. If you must cut wet pressure-treated wood, you can use the Material Conductivity Test described above to test whether the wood is too wet. If the test indicated the wood is too wet to cut with the safety system active, you must either allow the wood to dry or make the remaining cuts in Bypass Mode.

Note: if the saw shuts down due to an overload error, do not attempt to finish cutting that piece of wood until it has dried. The overload error indicates that the system was close to firing the brake before it went into overload. Therefore, repeatedly attempting to cut a wet piece of wood could result in an unnecessary activation of the brake.

USING YOUR SAW

Using the Blade Guard

Using the blade guard is one of the most important steps you can take to prevent injury. Many table saw injuries occur when the blade guard is either not being used or not being used properly. The blade guard on your SawStop® saw was designed to have a narrow profile that allows you to use the guard even when making narrow rip cuts. As a result, there are only a few situations where the blade guard cannot be used (e.g., dado cuts, rabbet cuts, and extremely narrow cuts).

Install the blade guard as described [on page 32](#). The side guards are mounted to the top guard so that they can pivot freely to automatically adjust to the height of the workpiece (up to 3 1/8 inches high).

The front of the top guard is formed into a wood stop that prevents wood that is too high to move through the blade guard from entering the guard ([see Fig. 57](#)).

The top guard can be placed in an upright position so that you can change the blade without removing the guard. Pull the top guard forward and then up, as shown [in Fig. 58](#), to release it from the front of the spreader. The top guard may then be placed in an upright position, balanced against the spreader, as shown [in Fig. 59](#). Once upright, the top guard may be removed from the spreader by lifting it up vertically. To reinstall the top guard in the spreader, reverse the process.

Fig. 57

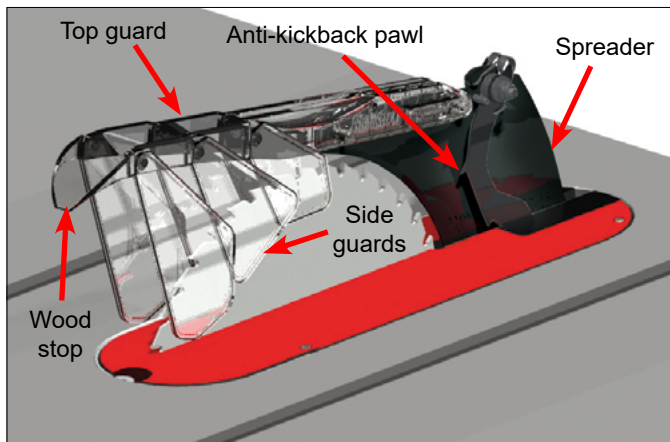

Fig. 58

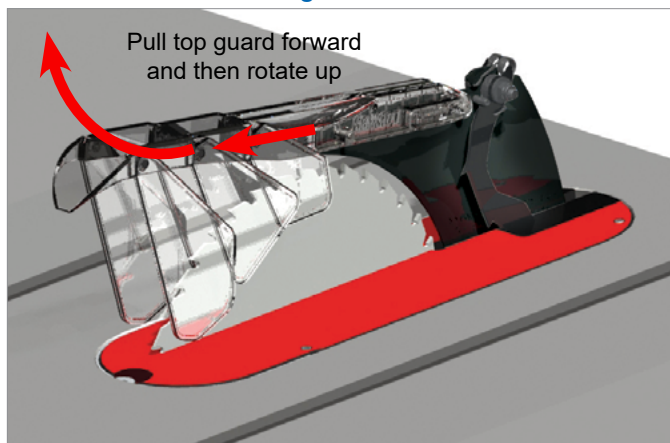
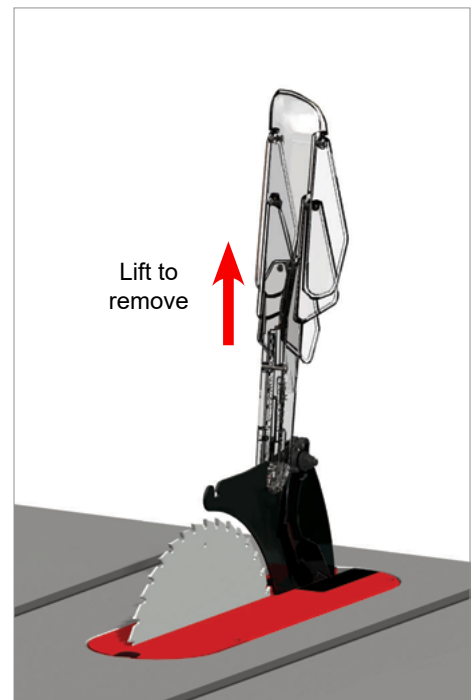

Fig. 59



WARNING! Use the blade guard for every operation for which it can be used, including all through-sawing. Note that since the spreader extends above the top of the blade it cannot be used as a riving knife, even if the top guard and the anti-kickback pawls are removed, as shown [in Fig. 59](#) and [Fig. 62](#).

USING YOUR SAW

The spreader helps minimize kickback by preventing a workpiece from pinching or shifting into the back of the blade. The spreader also supports a set of anti-kickback pawls to further minimize kickback.

In certain situations, such as cutting very soft wood, you may want to disable the anti-kickback pawls. The anti-kickback pawls may be disabled by rotating them up, as shown in **Fig. 60**. They will stay rotated up until you put them down again. Both anti-kickback pawls may be down together or up together, but they are not designed to be disabled independently.

The anti-kickback pawls may also be removed from the guard. To remove the anti-kickback pawls, hold both ends of the bolt that goes through the anti-kickback pawls and pull the bolt back to stretch the spring (see **Fig. 61**). Allow the anti-kickback pawls to rotate upwards as you stretch the spring (do not hold the anti-kickback pawls) then pull the bolt upwards to remove the anti-kickback pawl assembly (see **Fig. 62**).

Fig. 60

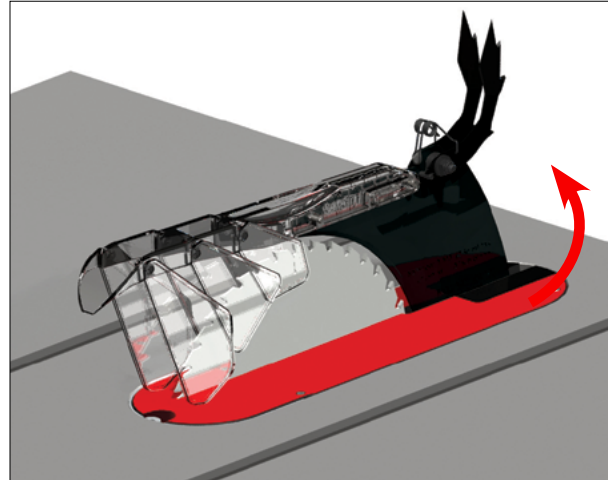
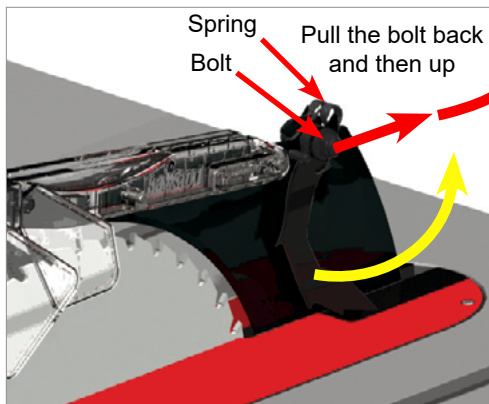
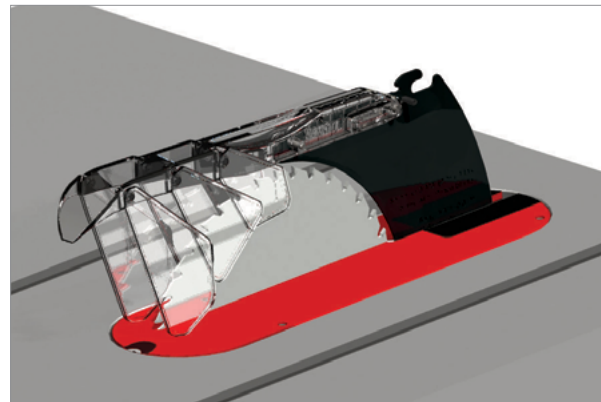

Fig. 61



Allow the anti-kickback pawls to rotate upwards - do not hold the anti-kickback pawls.

Fig. 62



To use the blade guard, set the blade elevation and tilt angle to the desired settings and, if necessary, install or swing down the top guard so that the side guards rest on the table or insert. Make sure the top guard is securely locked in place in the spreader before use.

Cut the workpiece as described beginning **on page 51**. The side guards will “float” on the top of the workpiece as the workpiece passes under the guard. The wood stop will prevent material that is taller than the height of the blade from entering the blade guard. The top guard and side guards are constructed of clear polycarbonate to allow you to clearly see the blade and the workpiece as it passes under the guard. After making the cut, the cut-off portion of the workpiece may be held beneath one of the anti-kickback pawls. In this case, turn off the motor and wait until the blade stops before pushing the cut-off portion past the anti-kickback pawl.

Keep the guard clean and free of dust to allow unobstructed viewing of the blade and workpiece. For successful operation, the spreader must remain flat, and the side guards and anti-kickback pawls must pivot freely. If any portion of the blade guard ceases to function properly, replace or repair it before continuing to use the saw. When not in use, the blade guard can be stored by hanging it on one of the storage pins on the left side of the saw (see **Fig. 64**).

USING YOUR SAW

Using the Riving Knife

To use the riving knife, remove the blade guard and install the riving knife as described [on page 32](#).

The riving knife should be used whenever the blade guard cannot be used ([see Fig. 63](#)). The only operations where neither the blade guard nor the riving knife can be used are operations such as making dado cuts. When the riving knife is properly aligned, it will be positioned below the top of the blade and inside the kerf of the blade. As a result, the riving knife can be used even for rabbet cuts and other non-through cuts.

For successful operation, the riving knife must remain flat so that the full height of the riving knife is positioned inside the kerf of the blade. In the event the riving knife becomes bent, replace or straighten it before continuing to use it. When not in use, the riving knife can be stored by hanging it on one of the storage pins on the left side of the saw ([see Fig. 27](#)).

Fig. 63



WARNING! Use the riving knife for every operation where the blade guard cannot be used. Neither the blade guard nor the riving knife can be used when making dado cuts.

Using the Miter Gauge

The miter gauge included with your saw allows you to make miter cuts and cross-cuts (cuts across the grain of the wood). When not in use, the miter gauge can be stored by hanging it on one of the storage pins on the left side of the saw ([see Fig. 64](#)).

The main bar of the miter gauge fits in the T-shaped slots in the table ([see Fig. 26](#)). There is one slot on each side of the blade and the miter gauge can be used in either slot. However, do not use the miter gauge in the slot on the left of the blade when making bevel cuts. Positioning the miter gauge in the left slot when making bevel cuts causes the blade to be tilted toward the miter gauge and the operator's hand which could result in a serious injury.

Fig. 64

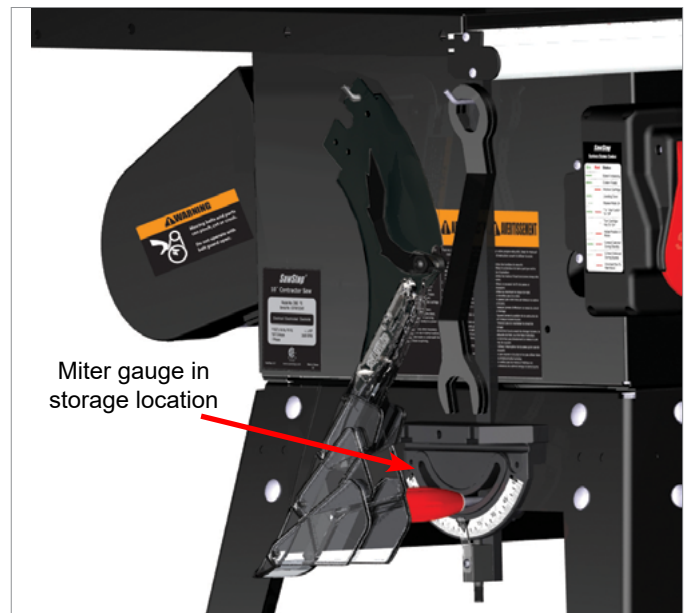

USING YOUR SAW

The face of the miter gauge can be adjusted between -60° and $+60^{\circ}$ relative to the blade. To adjust the miter angle, turn the handle counter-clockwise approximately 1/2 turn to unlock the miter gauge head (see Fig. 65). Pull the indexing pin out until it stops, and then rotate the head until the indicator is positioned over the desired angle on the miter gauge scale. Use an angle gauge to set the angle between the miter gauge head and the blade if precise alignment is needed. Once the angle is correct, turn the handle clockwise to lock the miter gauge head.

Adjustable index stops at -45° , 0° , and $+45^{\circ}$ are provided to allow quick and precise alignment at those angles. To use the index stops, rotate the miter gauge head until the angle indicator reads approximately 5° higher (more positive) than the desired angle, and then push the indexing pin forward until it stops. Next, rotate the miter gauge head counter-clockwise until the index stop hits the indexing pin, and then tighten the handle to lock the gauge at the desired angle. The index stops are preset at the factory to be within $\pm 0.5^{\circ}$ of the true angle, so further adjustment should not be necessary. If you wish to adjust the index stops, see page 73 for instructions.

For added safety, an optional wood face can be mounted to the miter gauge face to provide additional support when cutting large or small workpieces. To mount the face, use wood screws with shanks sized to fit through the slots in the miter gauge head. The wood face should be at least 1 inch higher than the maximum depth of cut, and should extend beyond the edges of the miter gauge head.

When using the miter gauge, start with the workpiece and miter gauge well in front of the blade. Grip the miter gauge handle with the hand closest to the blade, and place your other hand on the workpiece opposite the blade (see Fig. 66 and Fig. 67). Make sure the workpiece is held squarely and firmly against the miter gauge face and the table. Move the miter gauge and workpiece slowly and smoothly past the blade. For through-cuts, shift the workpiece slightly away from the blade before pulling the miter gauge and workpiece back toward the front of the saw. Do not touch the portion of the workpiece that was cut off until the blade stopped.

Fig. 65

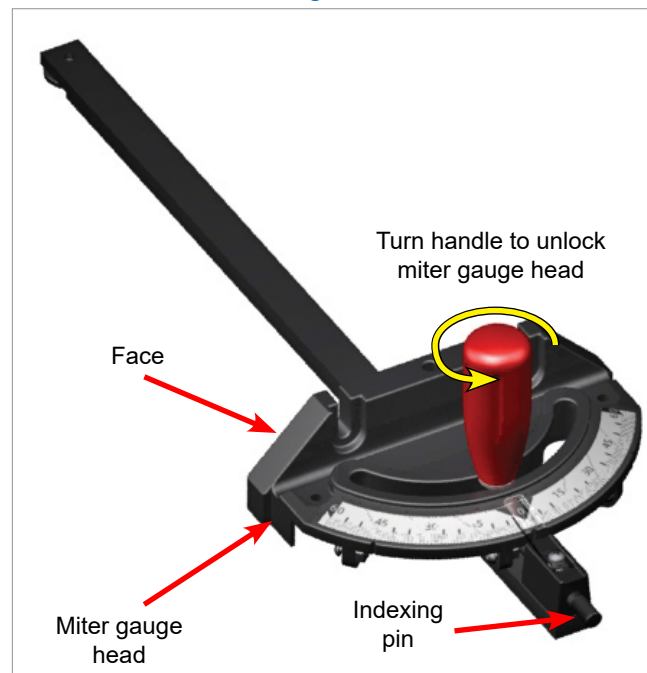

WARNING! Never make free-hand cuts. Never hold or touch an unsupported piece of wood while the blade is spinning.

USING YOUR SAW

Cross-Cutting

Cross-cutting (cutting perpendicular to the grain of the workpiece) is performed using the miter gauge. To lessen the risk of kickback, the rip fence should be removed or positioned so that it does not contact the workpiece during cross-cutting.

To begin, make sure the motor is off and the blade is completely stopped. Tilt the blade to the desired tilt angle and adjust the blade elevation to about 1/8 inch above the workpiece. Place the miter gauge in the right miter slot for bevel cuts, or in either the right or left miter slots for making non-bevel cuts. Adjust the miter gauge to the desired miter angle (see Fig. 65).

Position the workpiece against the miter gauge head and slowly push the miter gauge toward the non-spinning blade until the workpiece is almost touching the blade. Next, slide the workpiece to the left or right until the blade is aligned with the point on the workpiece to be cut. Pull the miter gauge and workpiece back away from the blade before starting the motor.

Once the motor reaches full speed, you can begin your cut. Holding the miter gauge and workpiece firmly, move the miter gauge and workpiece slowly and smoothly past the blade.

Fig. 66



Fig. 67



WARNING! To reduce the potential for kickback and a serious injury, move the rip fence out of contact with the workpiece when cross-cutting to prevent the workpiece from binding between the rip fence and the blade.

USING YOUR SAW

Using a Fence

You must install a rip fence prior to making rip cuts with the saw.

The SawStop® Premium Fence Assembly includes a T-style aluminum extrusion fence with nonconductive face plates (see Fig. 68). It also includes heavy-duty steel front and rear rails, a steel clamp tube, and dual cursors that allow the fence to be used on either side of the blade. This fence system has a 30 inch rip capacity.

Fig. 68



The SawStop® T-Glide™ Fence System - Professional Series is another fence system designed specifically for your saw (see Fig. 69). It is the best fence system available in the industry. The fence is constructed from heavy-duty steel tubing for maximum rigidity and includes high-quality, non-conductive face plates that maintain their flatness over time. The system also includes steel front and rear rails, a steel clamp tube, and SawStop's proprietary design that makes the fence slide smoothly. This fence system can be used with optional 36 or 52 inch extension tables.

You can learn more about the SawStop® fence systems from an authorized SawStop distributor or at www.sawstop.com.

Fig. 69



USING YOUR SAW

Rip Cutting

Rip cutting or cutting with the grain of the workpiece must be performed with a rip fence to support and guide the workpiece. The miter gauge should not be used when making rip cuts. The blade guard should be used for all through cuts.

To begin, make sure the motor is off and the blade is completely stopped. Tilt the blade to the desired tilt angle and adjust the blade elevation to about 1/8 inch above the workpiece. Position the rip fence for the desired rip width and lock the fence in place. Refer to the owner's manual that accompanied your rip fence for instructions on using your fence.

Fig. 70



WARNING! A rip fence must always be used when making rip cuts. Never perform a ripping operation freehand or a serious injury may result.

Position the workpiece flat on the table and flush against the side of the rip fence. Turn on the motor. Use both hands to push the workpiece smoothly toward the blade. It is important to always maintain at least 6 inches between your hands and the blade. If your hand that is closest to the blade comes within 6 inches of the blade, remove that hand from the workpiece and continue the cut using the hand that is closest to the fence or with both hands near the fence (see Fig. 71). If your hand closest to the fence also comes within 6 inches of the blade, remove that hand and use a push stick to finish the cut. A push stick is a tool that is used to push the work piece forward to make a cut while allowing the user to keep their hands at a safe distance from the blade. (See page 81 for instructions on making a push stick.)

Fig. 71



WARNING! To reduce the chance of a serious injury, always use a push stick or push block when your hand comes within 6 inches of the blade.

USING YOUR SAW

When using a push stick to feed your workpiece toward the blade, it can be difficult to maintain the position of the workpiece flush against the side of the rip fence. In these situations, use a featherboard to hold the workpiece against the fence (see page 84 for making a featherboard). Clamp the featherboard to the top of the table against the side of the workpiece opposite the rip fence to hold the workpiece flush against the fence (see Fig. 72).

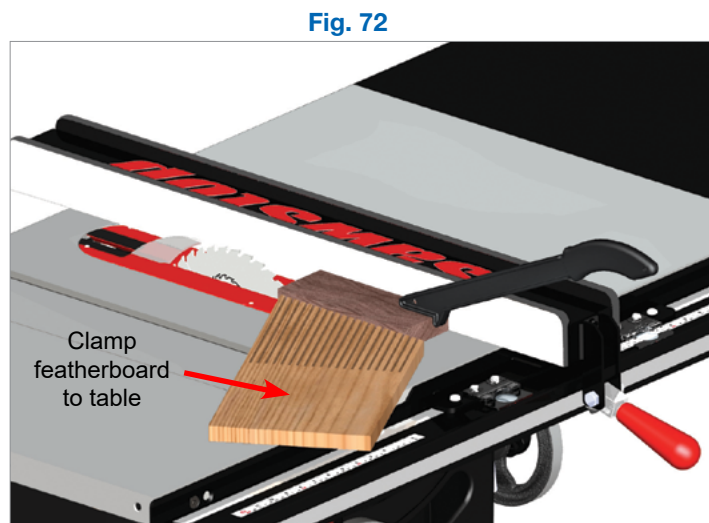

If your cut requires the fence to be positioned too close to the blade to use a push stick, use an auxiliary fence and a push block to make the cut. (See page 82 and page 83 for instructions on making an auxiliary fence and a push block.) In this case, clamp the auxiliary fence to the rip fence and slide the workpiece along the auxiliary fence. When your hand comes within 6 inches of the blade, remove your hand from the workpiece and finish the cut using the push block.

Continue pushing the workpiece toward the back of the saw until it clears the anti-kickback pawls on the spreader. Turn off the motor. Do not attempt to remove the cut-off portion until the blade has come to a complete stop.

When ripping pieces longer than approximately 4 feet, use rollers, an out-feed table or a similar support to prevent the workpiece from dropping off the back of the table.

When making non-through cuts, the blade guard and spreader must be removed. For these cuts, install the riving knife (except when making dado cuts) and use one or more featherboards to hold down the workpiece and help prevent kickback. (See page 84 for instructions on making a featherboard.) The featherboard should be clamped to the rip fence.

Alternatively, the featherboard can be clamped to an extender board that is clamped to the rip fence (see Fig. 73). Although not shown in the illustration, a second featherboard can be clamped to the top of the table and against the left side of the workpiece to hold the workpiece against the rip fence.

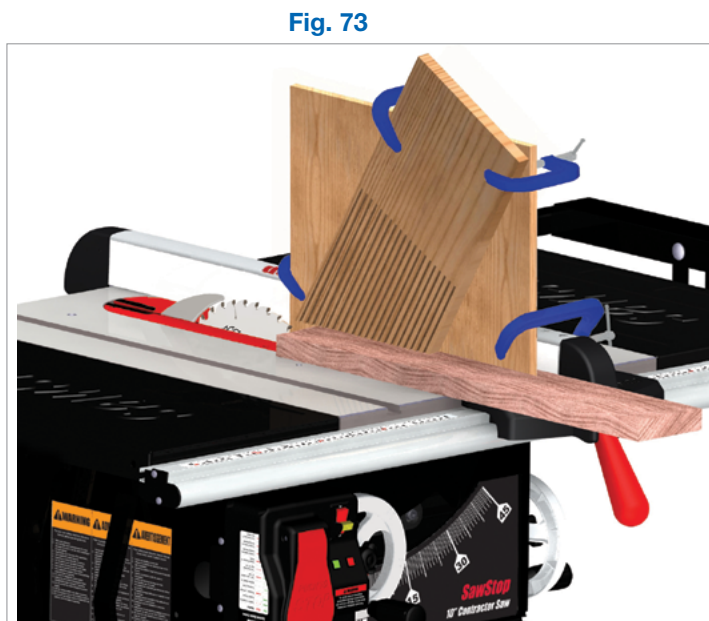

USING YOUR SAW

Using the Saw in Bypass Mode

If you need to cut electrically conductive materials such as aluminum with this saw, you must operate the saw in Bypass Mode to prevent the brake from activating. In order to operate the saw in Bypass Mode, the safety system requires you to follow the procedure below to ensure that the saw is never placed in Bypass Mode accidentally. If you are unsure whether a particular material is conductive, you can use the Material Conductivity Test described [on page 46](#).

Note: the saw will not start in Bypass Mode unless the brake cartridge is properly installed and all error codes are cleared. It is not possible to “override” an error by starting the saw in Bypass Mode.

To Operate the Saw in Bypass Mode

- a. Make sure the Start/Stop paddle is in the OFF position and then switch the Main Power switch to ON. Wait until the safety system completes the initialization routine and the system status code indicates the saw is ready for operation.

- b. Turn the Bypass Key clockwise and hold it for at least 1 second (see Fig. 74). The green LED will begin blinking slowly and the red LED will flash once to let you know when the 1 second has elapsed.

Note: to prevent unauthorized use of the saw in Bypass Mode, remove the Bypass Key from the saw when not in use.

- c. While still holding the Bypass Key turned, pull the Start/Stop paddle out to the ON position. The blade will start to spin.
- d. Continue to hold the Bypass Key turned for at least 1 second after the motor starts—the red LED will flash once again to let you know when the 1 second elapses. If you release the Bypass key before 1 second has elapsed, the motor will stop and the “Push Start/Stop Paddle to OFF” error code will be displayed. If this happens, switch the Start/Stop paddle to OFF and repeat this procedure from the beginning.

- e. When you have completed your cut, push the Start/Stop paddle in to turn off the motor. The safety system will remain in Bypass Mode until the blade comes to a complete stop. Once the blade has stopped, the safety system returns to normal Standby Mode. The next time you start the motor, the safety system will be active unless you repeat the procedure described above to start the motor in Bypass Mode.

Fig. 74

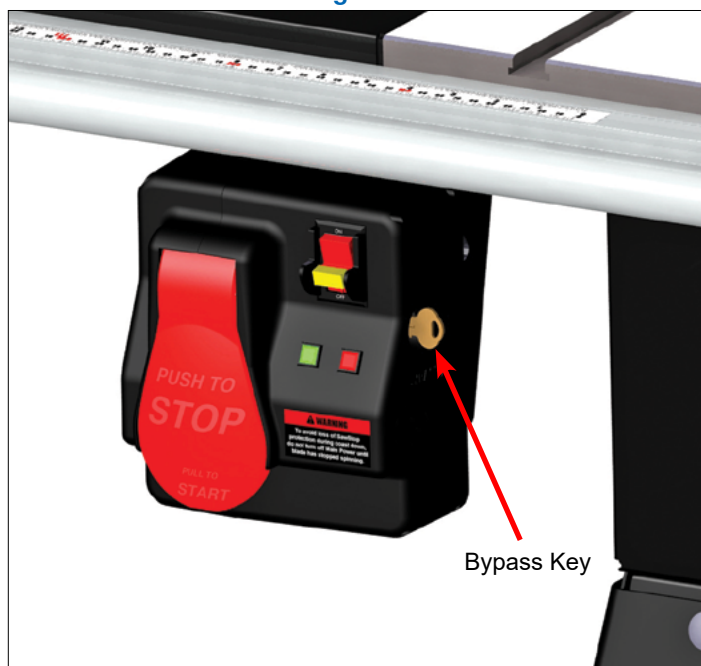

WARNING! Never run the saw in Bypass Mode unless necessary to cut conductive materials. The brake system will not activate when the saw is in Bypass Mode and a serious injury could result.

CAUTION! Always check the saw blade after cutting conductive materials. Sometimes a shard of aluminum or other conductive material will become embedded on the end of a saw blade tooth. If that occurs and the saw is started, then the shard could contact the aluminum brake pawl and cause the brake to activate.

USING YOUR SAW

Using a Mobile Base

The Contractor Saw is a stationary saw. In many situations it is important to be able to move the stationary saw from one location to another. For example, you may want to store the stationary saw against a wall in your workshop and then move it away from the wall to use it. SawStop offers an optional mobile base that allows you to reposition your stationary saw with ease.

The SawStop® Contractor Saw Mobile Base is designed specifically for your saw (see Fig. 75). It attaches to the stand and automatically lifts the saw onto the wheels when you step on a lever. When the wheels are down, you can roll the saw from one location to another. Stepping on a release will then raise the wheels and lower the saw back onto its feet.

Fig. 75



THE SAWSTOP® BRAKE CARTRIDGE

The SawStop® brake cartridge (see Fig. 76) includes a sealed housing containing the SawStop® system electronics, and an aluminum block called a brake pawl. The sealed housing also includes a high-speed actuator that pushes the brake pawl into the teeth of the saw blade in the event accidental contact is detected.

Like any electronic component, brake cartridges should be handled with care. Store brake cartridges in a safe, dry place when not in use. Do not drop, hit or otherwise subject brake cartridges to abuse as this may damage the cartridge. In addition, the high speed actuator could be unexpectedly triggered due to damage, thereby causing the brake pawl to be pushed away from the housing at very high speed and with a large amount of force.

The brake cartridge must be changed in the event the brake is activated. The brake cartridge must also be changed whenever swapping between 10 inch standard blades and dado sets. For dado cuts, the optional dado brake cartridge must be installed (see Fig. 77). The SawStop® dado cartridge is identical to the standard brake cartridge with the exception of the brake pawl. The dado brake pawl is larger than the standard brake pawl to accommodate the width and diameter of 8 inch dado sets. Other size dado sets or standard 10 inch blades are not compatible with the 8 inch dado cartridge.

Fig. 76

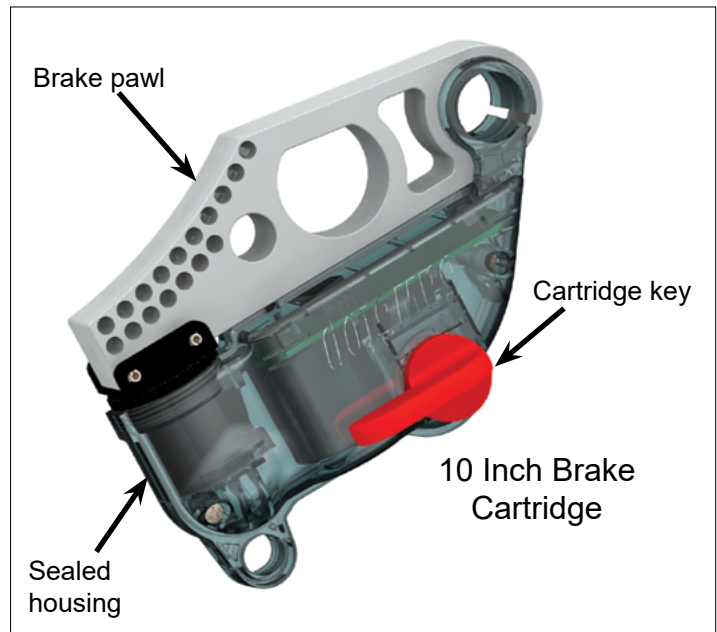
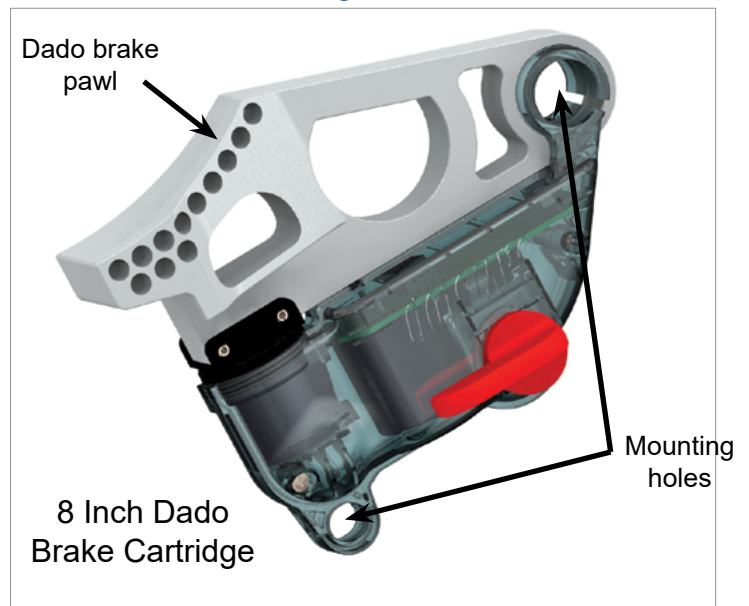

Fig. 77



Brake Cartridge

WARNING! Never drop or otherwise subject a brake cartridge to misuse as this may damage the brake cartridge and potentially cause the brake pawl to be released unexpectedly and result in a serious injury.

THE SAWSTOP® BRAKE CARTRIDGE

Changing the Brake Cartridge

Changing the brake cartridge is both simple and foolproof. The safety system will not allow the motor to start unless the brake cartridge is correctly installed. Before changing the brake cartridge, make sure the Start/Stop paddle is pushed in to the OFF position, the main power switch is toggled down to the OFF position, and the power cord is unplugged.

The brake cartridge is mounted beneath the table and behind the blade (see Fig. 78). To change the cartridge, begin by setting the tilt angle to about 0° and raising the blade elevation to the maximum height. This allows the easiest access to the brake cartridge.

Next, remove the table insert from the table (see page 28). Rotate the blade guard clamping handle fully upward to provide clearance for removing the brake cartridge.

Fig. 78

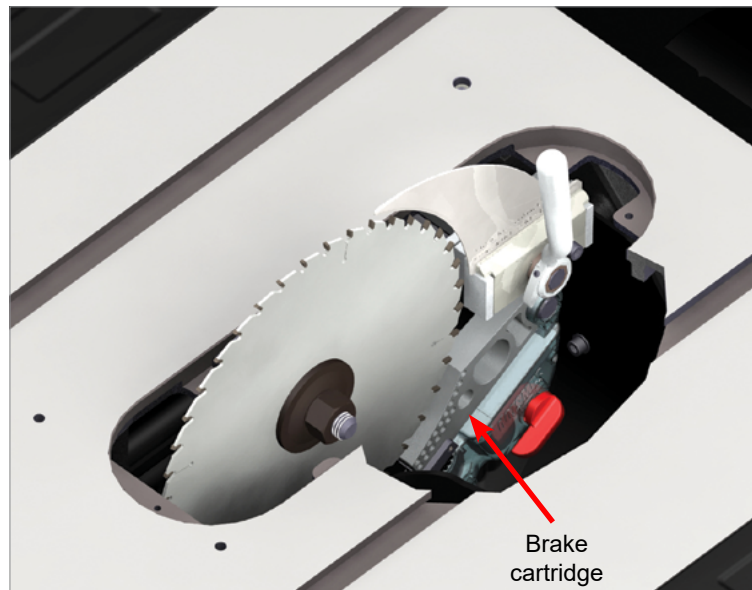

WARNING! Always turn off the main power switch and unplug the power cord before removing or installing the brake cartridge on your saw.

THE SAWSTOP® BRAKE CARTRIDGE

The brake cartridge is mounted on a large pivot pin and a smaller positioning pin (see Fig. 79). Both the pivot pin and positioning pin extend outward from a cartridge mounting bracket that sets the position of the cartridge. The cartridge mounting bracket also holds a computer cable that self-aligns to the computer connector in the side of the cartridge. A cartridge key is used to lock the brake cartridge in place against the cartridge mounting bracket.

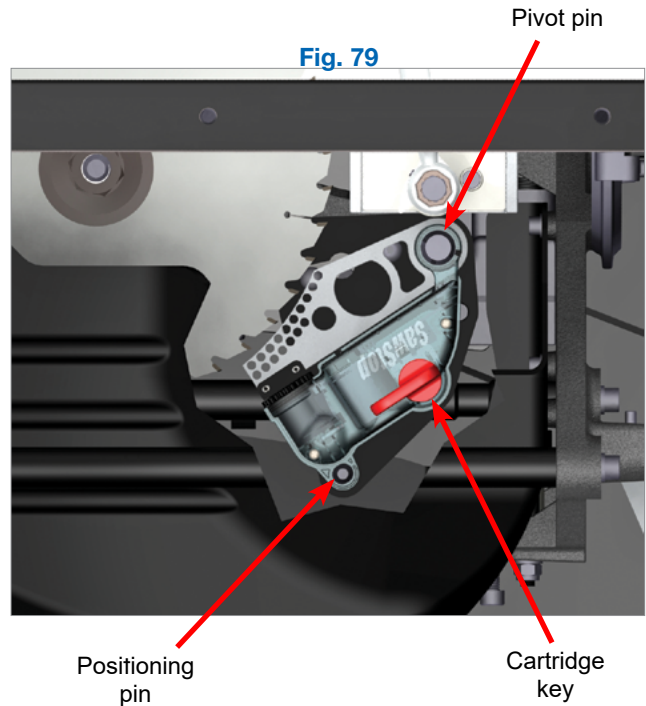

To remove the cartridge, first remove the cartridge key by turning it 90° clockwise and then pulling it away from the cartridge (see Fig. 80). Set the cartridge key aside for use with the new cartridge.

It may take a small amount of force to turn the key and pull it out. Make sure you turn the key a full 90°, as the key cannot be pulled out unless it has been fully rotated.

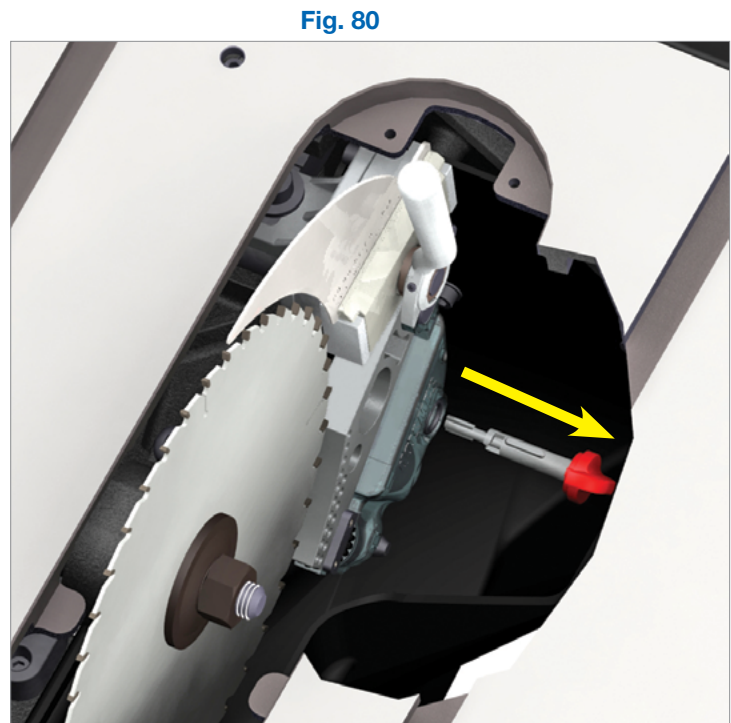

THE SAWSTOP® BRAKE CARTRIDGE

If the brake cartridge has not been activated, slide the brake cartridge to the right until it clears both pins (see Fig. 81).

Fig. 81



If the cartridge has been activated, the brake pawl typically will be locked onto the blade or dado set. As a result, it is usually easiest to remove the blade and the brake cartridge together. To remove the cartridge and blade together, first remove the blade nut and washer, and then remove the cartridge key by turning it 90° clockwise and pulling it away from the cartridge (see Fig. 80). You can remove the blade and brake cartridge simultaneously by alternately moving the blade and then the cartridge to the right to “walk” them off the arbor and pins. Often you can “walk” them to the right by hand, but if not, you can use a blade wrench as a lever. To do this, place one end of the wrench between the blade and the side of the arbor block, and then push the blade a short distance away from the arbor flange (see Fig. 82). Then place the end of the wrench between the brake pawl and the cartridge mounting bracket to pry the cartridge away from the arbor block a short distance (see Fig. 83). Only move the blade and cartridge a short distance each step, for example, a distance equal to one or two threads on the arbor. Otherwise the brake cartridge may bind on the arbor and pivot pin. Repeat these steps to walk the cartridge and blade off. A significant force may be needed to pry the cartridge off the mounting pin if the brake pawl deformed and pinched the pivot pin when it stopped the blade.

Fig. 82



Fig. 83



THE SAWSTOP® BRAKE CARTRIDGE

Installing a Brake Cartridge

WARNING! Always turn off the main power switch and unplug the power cord before removing or installing the brake cartridge on your saw.

To install a brake cartridge, the above process is reversed. Align the mounting holes in the cartridge with the pivot pin and positioning pin in the saw. Slide the cartridge onto the pins until the cartridge rests against the mounting bracket. The cartridge will automatically align with a computer cable mounted in the saw.

Next, insert the cartridge key into the hole in the cartridge housing (see Fig. 79 on page 59). The key shaft has a ridge that must be aligned with a channel in the hole. As a result, the key can only be inserted into the hole when the red handle is pointing toward the brake pawl. Insert the key fully into the hole and rotate the key 90° counter-clockwise to lock the cartridge in place. The key will not rotate unless it is fully seated against the side of the cartridge housing and the cartridge housing is pressed against the cartridge mounting bracket.

Once the key is rotated to its locked position, it cannot be removed and the cartridge will be locked in place. Rotating the key to the locked position also actuates a switch inside the cartridge that signals to the safety system that the cartridge is correctly installed and locked in place. The system will not allow the saw to start if the switch is not actuated. If you attempt to turn on the saw when the key is not in the locked position, the LED lights on the switch box will flash a status code indicating the key should be turned to ON. Turning the key to ON means turning the key to the locked position.

To complete the installation, the brake cartridge must be correctly positioned relative to the blade or dado set. Once the brake cartridge is installed, fully rotate the blade guard clamping handle counter-clockwise to lock the spreader or riving knife in place. Next, install the blade or dado set as described on page 29, and adjust the brake position as described on page 30. Rotate the blade by hand at least one complete revolution to ensure that the blade does not contact the brake.

WARNING! Always check, and if necessary, adjust the position of the brake after changing the brake cartridge or the blade. An improperly positioned brake could increase the time required to stop the blade in the event of accidental contact, or cause the brake to actuate unexpectedly if the blade comes into contact with the brake.

WHAT TO DO IF THE SAWSTOP® SAFETY SYSTEM ACTIVATES

When the **SawStop®** safety system is activated, the brake pawl will be pushed into the blade to stop its rotation. If the blade is spinning at a significant speed, the arbor block will retract to lower the blade below the table. Both of these actions will occur within just a few milliseconds. In addition, the safety system will turn off the motor and display the “Replace Cartridge” system status code on the LED lights on the switch box ([see page 44](#)).

Once the safety brake is activated, you will need to carry out the 3 steps described below to reset the safety system and the saw before continuing to use the saw.

1. **Reset the Retraction of the Arbor Block:** During normal use, the arbor block is held in place by a spring-loaded support mechanism called the retraction bracket. When the brake is activated, the angular momentum of the spinning blade is transferred to the arbor block, causing it to drop out of the retraction bracket.

To reset the arbor block into the retraction bracket, fully lower the blade by turning the elevation hand wheel counter-clockwise until the lower elevation limit stop is reached. The arbor block will automatically engage the support mechanism. Now turn the elevation hand wheel clockwise to raise the arbor block and blade.

2. **Replace the Brake Cartridge:** The **SawStop®** brake cartridge must be replaced in the event the brake is activated. The brake pawl and components inside the sealed housing are expended when the brake is activated. Therefore, the brake cartridge cannot be reused after the brake is activated and it may be discarded or returned to SawStop. Once the activated cartridge has been removed, obtain another brake cartridge that has not been activated and follow the instructions [on page 61](#) to install it.

If the brake activated due to accidental contact between the blade and an operator, please return the cartridge to SawStop. During use the cartridge is constantly measuring data about the operation of the saw and the signal received from the blade. When the brake is activated, the most recent data is stored into memory and SawStop can download the data from the activated cartridge. This data is very important to our continuing research and development program. Therefore, contact SawStop to arrange shipment of the cartridge back to SawStop. Once SawStop’s engineers verify the brake activated due to accidental skin contact, you will receive a replacement cartridge free of charge.

If you are unsure why the cartridge activated, you can return the cartridge to SawStop for analysis by SawStop’s service engineers. When the cartridge data is downloaded, it is usually possible to determine what caused the brake to activate so that further unintended activations can be prevented.

WARNING! Always turn off the main power switch and unplug the power cord before replacing the brake cartridge on your saw.

3. **Change the Blade:** When the brake is activated the aluminum brake pawl will pivot into the teeth of the saw blade with a large amount of force and speed. This usually causes the brake pawl to lock-up on the blade. If you remove the brake pawl from the blade, one or more of the carbide teeth on the blade will usually be pulled off. Therefore, it is almost always necessary to replace or repair the blade after the safety system has been activated.

Once the retraction of the arbor block has been reset and the brake cartridge and blade have been replaced, the saw is ready for operation.

MAKING ADJUSTMENTS TO YOUR SAW

Adjusting the Elevation Limit Stops

The upper elevation limit stop prevents the arbor block and the motor belt from hitting the underside of the table. The lower elevation limit stop prevents the arbor block or blade from hitting the lower trunnion assembly and dust shroud. The elevation limit stops must be adjusted correctly to ensure proper operation of the saw.

WARNING! Always turn off the main power switch and unplug the power cord before making any adjustments to your saw.

Upper Elevation Limit Stop

To check the position of the upper elevation limit stop, set the blade tilt to 0° , install a 10 inch saw blade on the arbor (see page 29), and turn the elevation hand-wheel clockwise until the limit stop is reached. Using a combination square or similar tool, measure the distance from the top of the table to the tip of the highest tooth on the blade (see Fig. 84). The maximum height of the blade above the table should be $3\frac{1}{8}$ inches. If the blade is $3\frac{3}{16}$ inches or higher above the table, the upper elevation limit stop should be adjusted downward. If the blade is less than $3\frac{1}{8}$ inches above the table, you can adjust the limit stop upward to $3\frac{1}{8}$ inches. Alternatively, you can adjust the limit stop so that the maximum blade height is lower than $3\frac{1}{8}$ inches.

Fig. 84

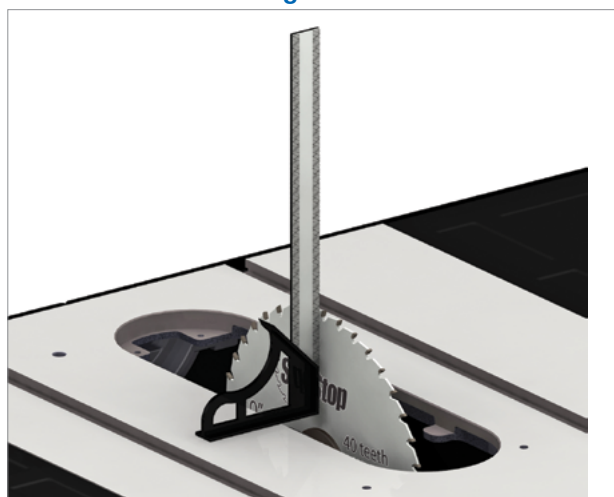

The upper elevation limit stop is fixed by the set screw in the cast iron table top located to the left of the rear of the table opening (see Fig. 85). The upper elevation limit bolt can be adjusted with the included 3 mm hex key.

To lower the maximum blade elevation, adjust the elevation hand-wheel until the blade elevation is set to the correct maximum height. Thread the set screw in clockwise until it is tight. To raise the maximum blade elevation, begin by turning the set screw counter-clockwise about one complete revolution. Then, adjust the elevation hand-wheel until the blade elevation is set to the correct maximum height. If the upper elevation limit stop prevents you from raising the blade to the desired maximum elevation, continue to turn the set screw counter-clockwise until the blade can be raised to the correct elevation. Once the blade is set to the correct maximum elevation, turn the set screw clockwise until it is tight. The upper elevation limit has now been set.

Fig. 85



MAKING ADJUSTMENTS TO YOUR SAW

Lower Elevation Limit Stop

To check the position of the lower elevation limit stop, turn the elevation hand-wheel counter-clockwise until the blade is lowered all the way. The top of the blade should be approximately $\frac{1}{8}$ inch below the table top surface. If the distance is approximately $\frac{1}{8}$ inch, no further adjustment is necessary.

If adjustment is necessary, the lower elevation limit stop is fixed by the M6 socket head screw on the bottom of the rear trunnion (see Fig. 86). The head of the lower elevation limit screw is painted yellow to make it easier to locate. Loosen the M6 hex nut that locks the position of the limit screw by rotating it counter-clockwise with a 10 mm wrench. Next, thread the lower elevation screw out counter-clockwise with the included 5 mm hex key at least two complete revolutions. Then turn the elevation hand-wheel counter-clockwise until the arbor slightly compresses the rubber bumper (see Fig. 87).

The purpose of the rubber bumper is to absorb the energy of the arbor block when the blade retracts below the table upon activation of the safety system. As shown in Fig. 87, the lower elevation limit stop should be adjusted so that the arbor block slightly compresses the bumper at the lowest elevation. This should also ensure that a 10 inch blade is at least $\frac{1}{8}$ inch below the top of the table.

Verify that the top of the blade is approximately $\frac{1}{8}$ inch below the table top surface. Thread the lower elevation screw in clockwise until it is tight and then lock its position by tightening the M6 hex nut against the rear trunnion. The lower elevation limit has now been set.

Fig. 86



Lower elevation limit stop

M6 hex nut

Fig. 87

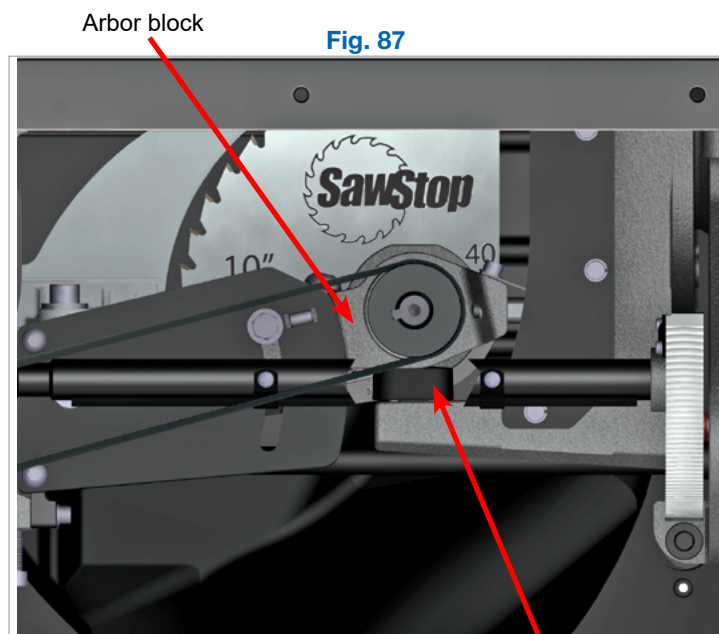

Arbor block

Rubber bumper

MAKING ADJUSTMENTS TO YOUR SAW

Adjusting the Tilt Limit Stops and Tilt Angle Indicator

The tilt limit stops allow you to easily and quickly set the bevel angle to 0° and 45°. However, when making precision cuts, it is always best to check the angle of the blade with a combination square or similar tool.

WARNING! Always turn off the main power switch and unplug the power cord before making any adjustments to your saw.

0° Tilt Limit Stop

To check the position of the 0° limit stop, install a 10 inch saw blade on the arbor (see page 29). Raise the blade to its full elevation, and turn the tilt hand-wheel counter-clockwise until the limit stop is reached. Using a square, check to see that the blade is at a 90° angle to the table (see Fig. 88). If you need to adjust the position of the 0° limit stop follow the instructions below.

Fig. 88



Fig. 89

The 0° tilt limit stop is determined by the set screw in the cast iron table top located to the left of the front of the table opening. (see Fig. 89). Use the included 3 mm hex key to turn the screw counter-clockwise several turns.

Next, adjust the tilt hand-wheel until the blade is at 90° to the table. Turn the 0° limit set screw clockwise until it is tight. The 0° limit stop has now been set.

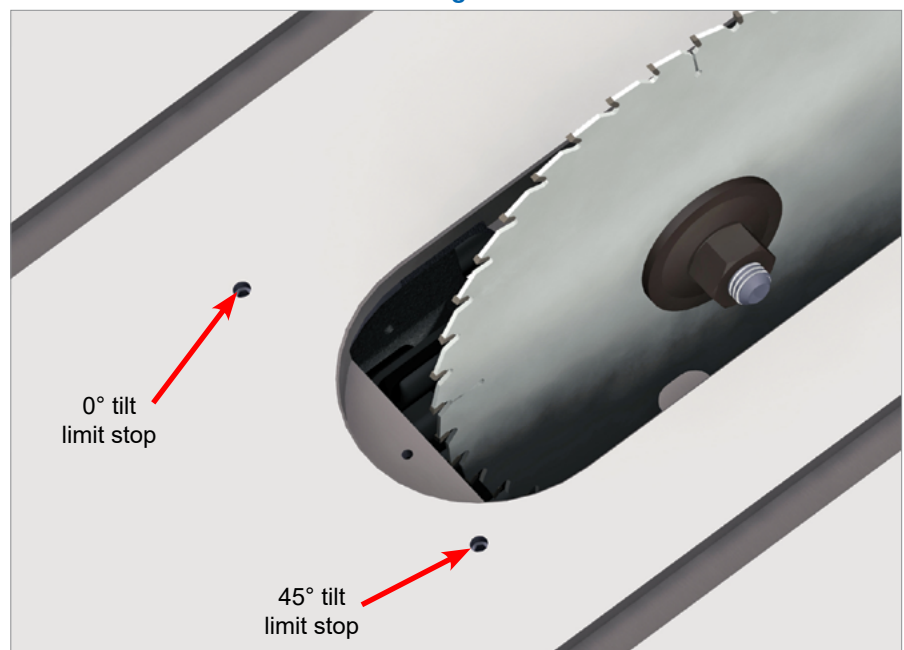

MAKING ADJUSTMENTS TO YOUR SAW

45° Tilt Limit Stop

To check the position of the 45° limit stop, install a 10 inch saw blade on the arbor (see page 29). Raise the blade to its full elevation, and turn the tilt hand wheel clockwise until the limit stop is reached. Using a combination square, check to see that the blade is at a 45° angle to the table (see Fig. 90). If you need to adjust the position of the 45° limit stop follow the instructions below.

The 45° tilt limit stop is determined by the set screw in the cast iron table top located to the right of the front of the table opening (see Fig. 89). Use the included 3 mm hex key to turn the screw counter-clockwise several turns.

Next, adjust the tilt hand wheel until the blade is at 45° to the table. Turn the 45° limit set screw clockwise until it is tight. The 45° limit stop has now been set.

Fig. 90

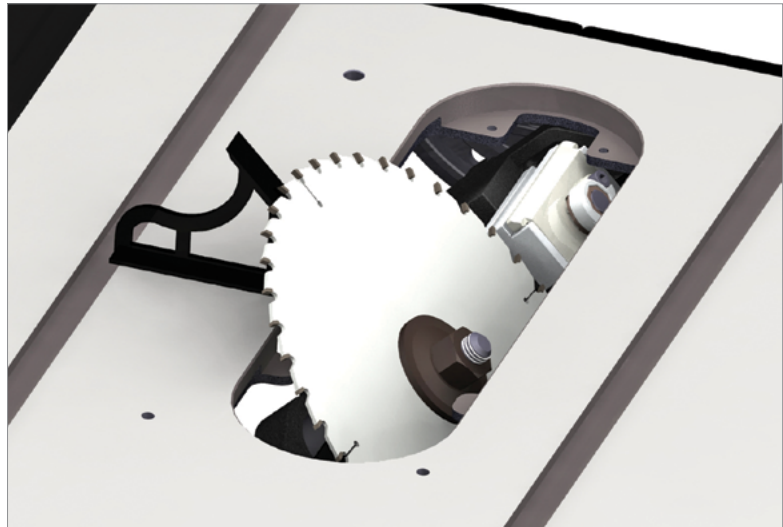

Tilt Angle Indicator

The tilt angle indicator is located at the front of the Contractor Saw, just behind the elevation hand-wheel (see Fig. 91). The indicator shows the current angle of the blade relative to vertical (i.e., perpendicular to the table top).

Once the 0° limit stop is correctly set, turn the tilt hand-wheel counter-clockwise until the limit stop is reached. Check the reading of the tilt angle indicator. If necessary adjust the indicator by loosening the locking screw with the included 5 mm hex key and rotating the indicator until it reads 0°. Lock the indicator in place by tightening the locking screw.

Fig. 91

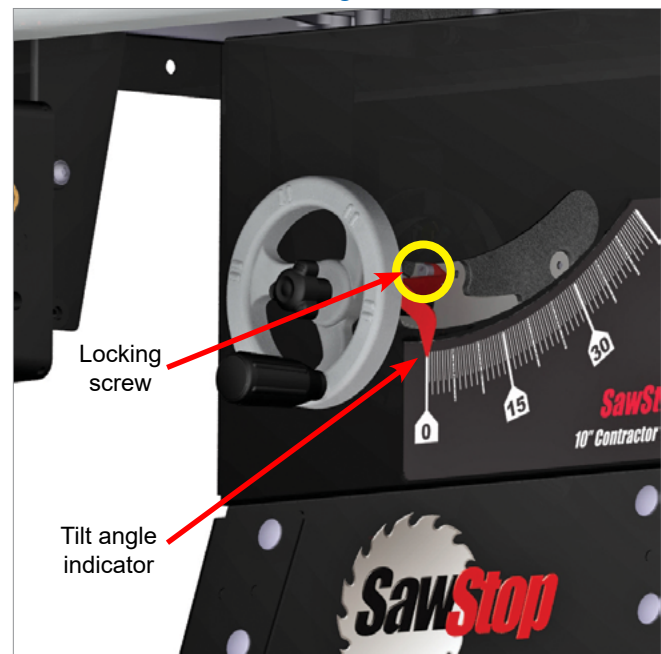

MAKING ADJUSTMENTS TO YOUR SAW

Adjusting the Table Insert

The **SawStop®** zero-clearance insert has been designed to fit securely within the table opening and just below the table top. The blade slot in the insert is pre-cut at the factory after all alignments to the saw have been completed.

As shown in **Fig. 92**, the insert includes front and rear leveling screws to set the height of the insert. In addition, positioning screws at the rear and right side of the insert prevent it from rattling in the table opening. Finally, a lock-down lever at the front prevents the insert from rising unexpectedly.

Fig. 92

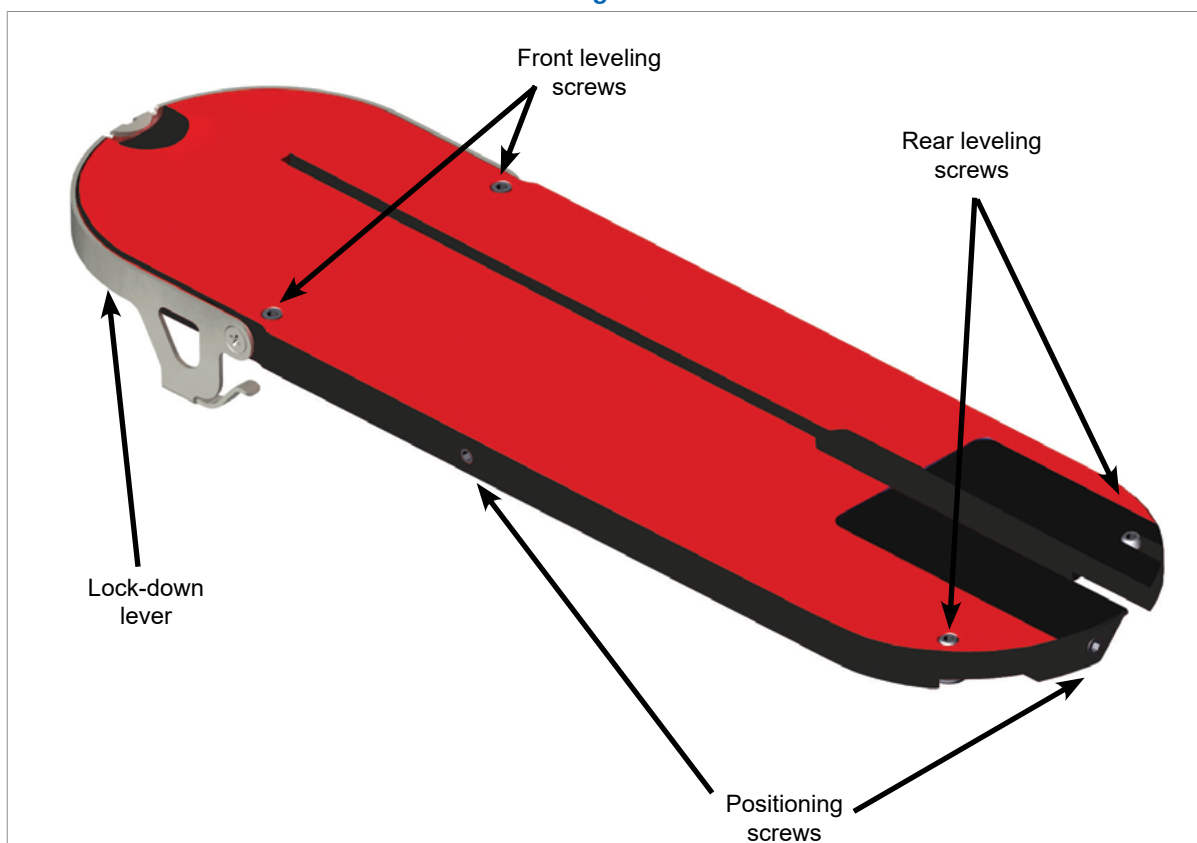

WARNING! Always turn off the main power switch and unplug the power cord before making any adjustments to your saw.

The insert should slide easily into and out of the table opening, but should not be loose in the opening. If the insert is too loose, use the included 3 mm hex key to turn the side and/or rear positioning screw(s) counter-clockwise as needed to reduce the clearance between the insert and the table opening (see **Fig. 92**). If the insert is too tight, turn the side and/or rear positioning screw(s) clockwise as needed to increase the clearance between the insert and the table opening.

MAKING ADJUSTMENTS TO YOUR SAW

To set the height of the insert, use the included 3 mm hex key to adjust the front and rear leveling screws until the insert is just below the surface of the table. The lower end of each front leveling screw should rest on the corresponding support ledge on the table (see Fig. 93). When the lock-down lever is in the down and locked position, latching arms extend under each of the support ledges to prevent the insert from rising up.

Fig. 93

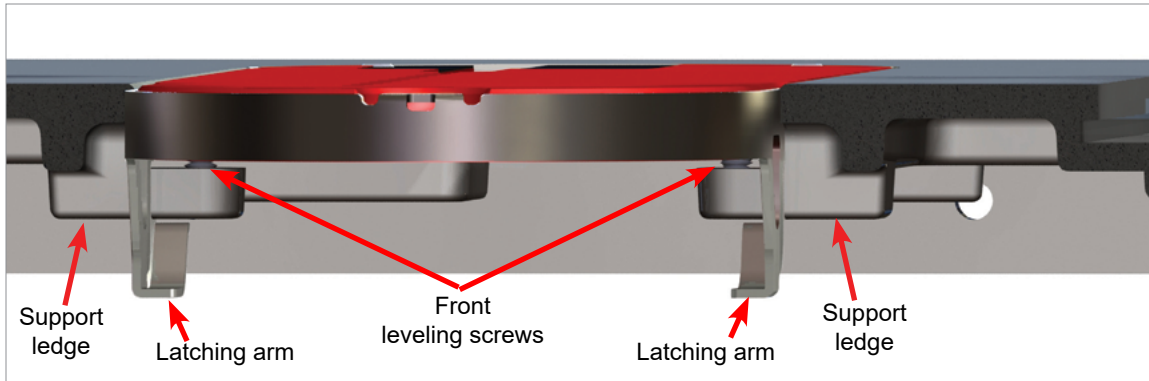

Adjusting the Rear Lock Down Screws

The rear of the table insert is held down by a pair of lock down screws mounted in the table at the rear of the table opening. As shown in Fig. 94, the lock down screw heads overlap the heads of the rear leveling screws extending down from the insert. The overlapping screw heads hold down the table insert.

The height of the lock down screws should be adjusted to fit close above the leveling screws, while allowing enough clearance to install and remove the table insert without difficulty. The height of the lock down screws can be adjusted using the included 3 mm hex key.

Fig. 94

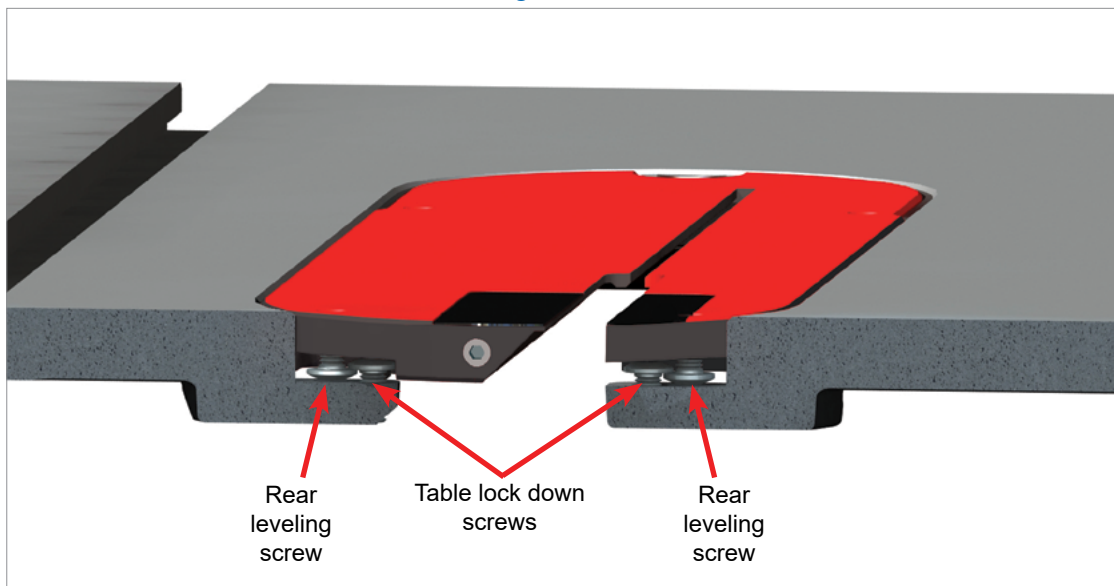

MAKING ADJUSTMENTS TO YOUR SAW

Aligning the Riving Knife and Spreader to the Blade

For safe operation, the spreader and riving knife should be aligned parallel to the blade and positioned inside the kerf of the blade (see Fig. 95).

WARNING! Always turn off the main power switch and unplug the power cord before making any adjustments to your saw.

Fig. 95

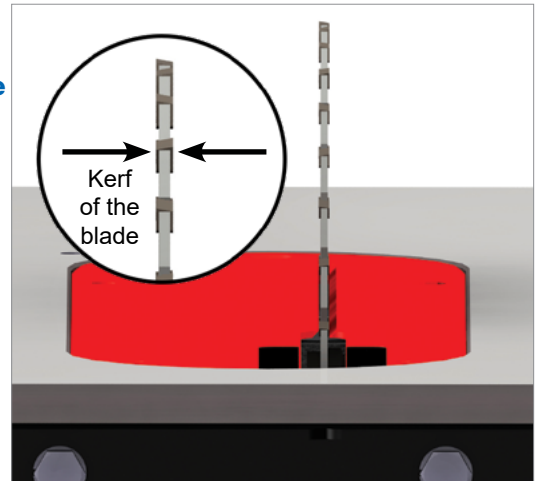

There should also be a gap of approximately 4-8 mm between the front edge of the spreader or riving knife and the teeth of the blade (see Fig. 96). If the spreader or riving knife is not aligned with the blade or is too close to the blade, then its position must be adjusted. The spreader or riving knife is held in position by a quick-release clamp mounted under the table and behind the blade (see Fig. 97). Once the clamp is properly adjusted, the spreader and riving knife will automatically align to the blade when installed in the clamp.

Fig. 96

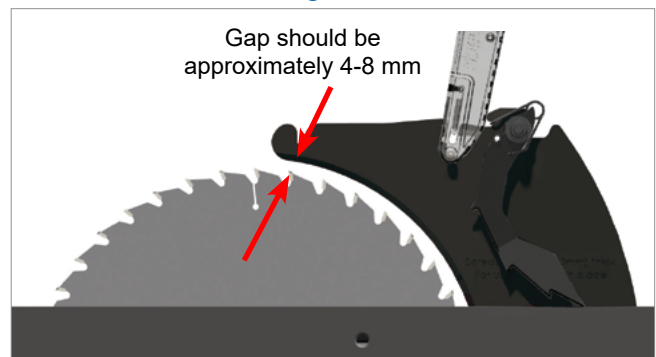

To adjust the clamp, set the tilt angle to 0° and remove the table insert. Remove the blade and set it aside. Make sure the spreader or riving knife is installed and lower the blade elevation to zero to provide access to the clamp.

Two mounting bolts hold the quick-release clamp in the saw (see Fig. 97). Loosen both mounting bolts (using an 8 mm hex key) just enough so that you can slide the clamp along its mounting surface with some friction. Reinstall the blade and raise the blade to the fully elevated position.

Fig. 97

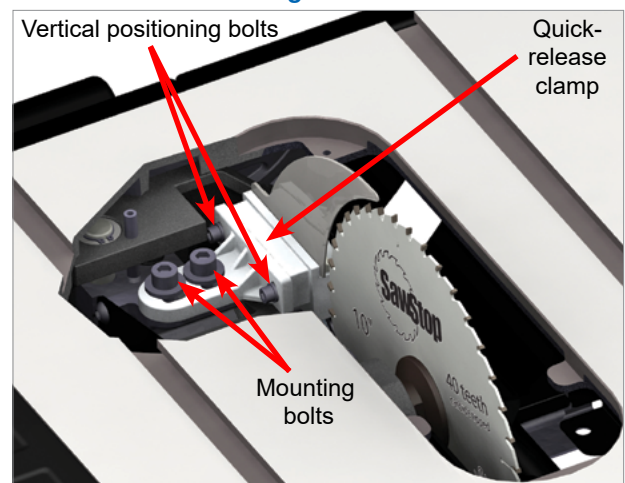

MAKING ADJUSTMENTS TO YOUR SAW

To align the spreader or riving knife so it is within the kerf of the blade, place a straight edge along the left side of the blade, making sure the straight edge runs between the teeth (see Fig. 98). Slide the clamp left or right until the left side of the spreader is flush and flat against the straight edge. If necessary, pivot the left anti-kickback pawl up out of the way while performing this step. If you are using a thin-kerf blade (i.e., kerf is $\frac{3}{32}$ inch), you may need to place one or more shims between the straight edge and the side of the blade to ensure the spreader is centered with the blade.

Fig. 98

To adjust the gap between the front edge of the spreader or riving knife and the teeth of the blade, slide the clamp forward or backward until the spacing is approximately correct.

When the spreader or riving knife is both aligned and spaced properly, tighten the two mounting bolts to hold the quick-release clamp in position. You may need to remove the blade to fully tighten the mounting bolts.

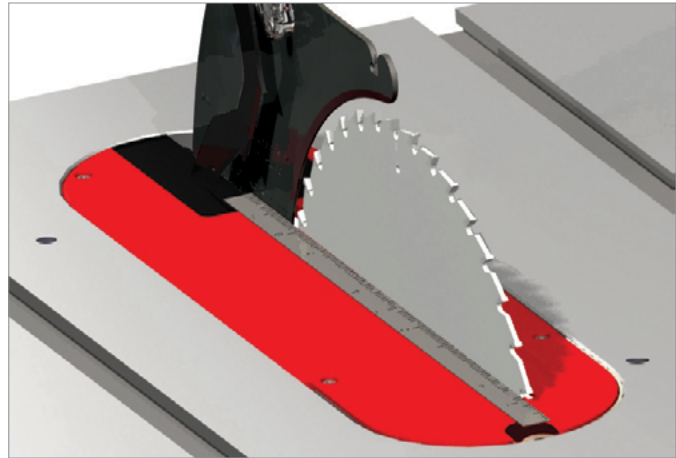

WARNING! Make sure there is at least 4 mm spacing between the riving knife and blade at all points. Contact between the blade and either the riving knife or spreader during operation may cause the brake system to be activated.

Adjusting the Height of the Riving Knife

When using the riving knife, the top of the riving knife should be between 1-5 mm below the top of the blade (see Fig. 99). This allows the riving knife to be used on rabbet cuts and other non-through cuts.

Fig. 99

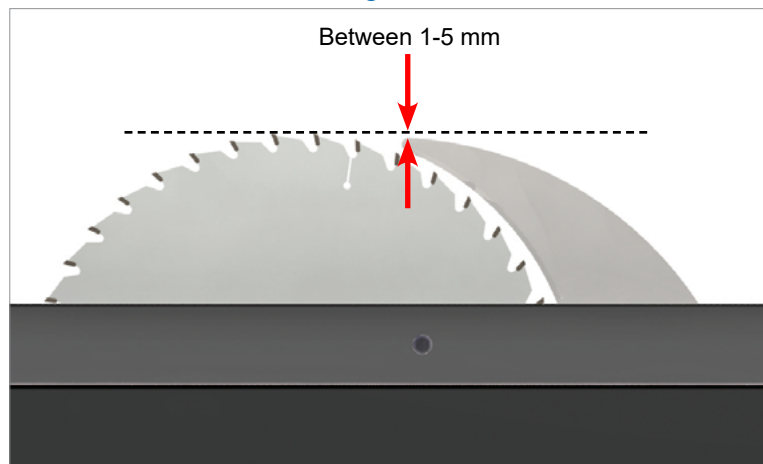

WARNING! Always turn off the main power switch and unplug the power cord before making any adjustments to your saw.

MAKING ADJUSTMENTS TO YOUR SAW

To check the height of the riving knife relative to the blade, lower the blade elevation until the lower limit stop is engaged. Place a ruler or another straight edge on the table insert directly above the tip of the riving knife. Raise the blade elevation until the tip of the riving knife just comes in contact with the straight edge or ruler ([see Fig. 100](#)).

Now measure the distance from the top of the table insert to the top of the blade. If the height of the riving knife is set correctly, the saw blade should be between 1-5 mm above the table insert. If the distance is between

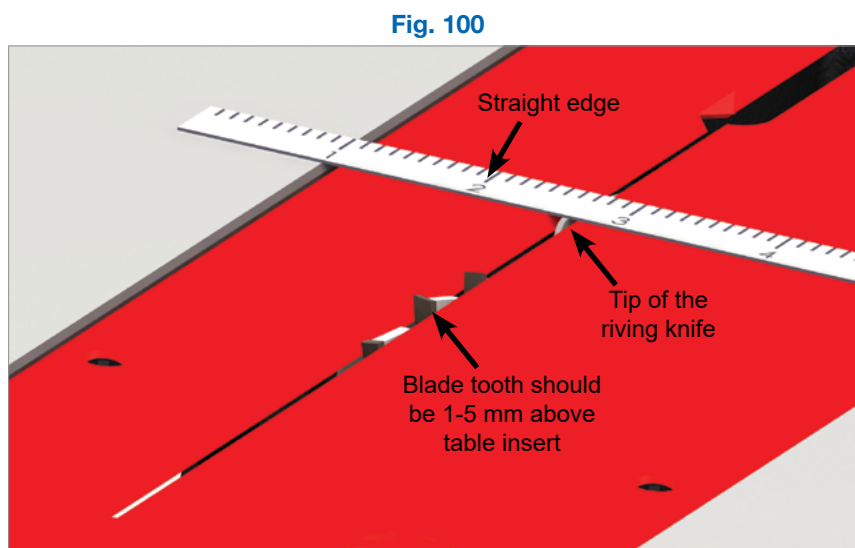

1-5 mm, no further clamp adjustments are necessary.

If the height of the riving knife is not correct, use the elevation hand-wheel to set the top of the blade to 1-5 mm above the top of the table insert. Next, remove the table insert and loosen the two vertical positioning bolts shown [in Fig. 97](#) using the included 5 mm hex key. Loosen the bolts just enough so that you can slide the clamp up and down on the clamp mounting bracket.

Next, adjust the position of the clamp up or down to set the height of the riving knife. You can also rotate the clamp forward or backward so that the arc on the front edge of the riving knife is concentric with the blade. When the riving knife is correctly positioned, tighten the two vertical positioning bolts just enough to hold the clamp in position and reinstall the table insert. Check to make sure the tip of the riving knife is level with the insert. Repeat the adjustment if necessary. Once the vertical alignment of the riving knife is correct, fully tighten the two vertical positioning bolts.

In some cases, adjusting the vertical alignment may cause the spacing between the front edge of the riving knife and the teeth of the blade to be incorrect. If this happens, repeat the steps explained above to adjust the gap between the front edge of the spreader and the teeth of the blade so that it is 4-8 mm.

Once the clamp has been properly positioned, further adjustment should not be necessary. Both the spreader and riving knife will now automatically align when installed in the clamp.

MAKING ADJUSTMENTS TO YOUR SAW

Adjusting the Quick-Release Clamp

The clamping pressure holding the spreader or riving knife in the quick-release clamp is factory adjusted to require approximately 5-10 lbs. of force to push the handle to the fully down and clamped position. This is a moderate amount of force to apply with one hand. If excessive force is required to move the handle down, or if you are unable to move the handle down by hand, then the clamp should be adjusted to reduce the clamping pressure. Alternatively, if the handle moves down with only light pressure, then the clamping force should be increased. When evaluating the clamping force, make sure the riving knife or spreader is properly seated in the clamp.

WARNING! Always turn off the main power switch and unplug the power cord before making any adjustments to your saw.

To adjust the clamping force, begin by removing the riving knife or spreader. Raise the handle so that it faces upward, and push the handle toward the clamp. The clamp assembly includes an internal spring designed to push the clamp open when the handle is raised. Therefore you will have to push the handle toward the clamp against the force of the spring.

When the handle is fully pressed against the clamp, an adjustment bolt will be exposed as shown in Fig. 101. Turn the adjustment bolt clockwise a slight amount to increase the clamping pressure, or counter-clockwise a slight amount to decrease the clamping pressure. Release the handle and allow the spring to push it away from the clamp and re-engage the adjustment bolt. Now reinstall the spreader or riving knife and test the clamping pressure. Repeat the adjustment as necessary until the correct clamping pressure is achieved.

Fig. 101

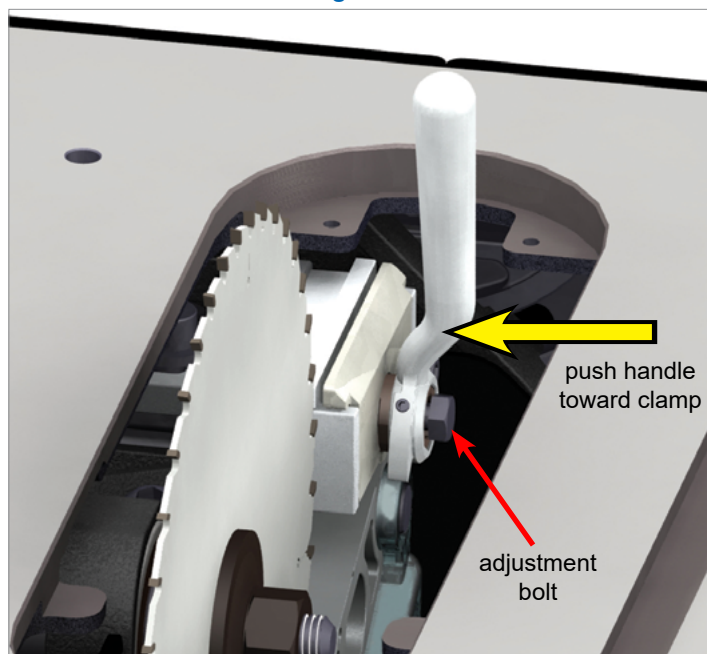

WARNING! It is important to maintain the correct clamping pressure on the riving knife and spreader. If the pressure is too low these important safety devices may not function properly and a serious injury could result. In addition, the spreader or riving knife may come into contact with the blade and cause an unintended activation of the safety system.

MAKING ADJUSTMENTS TO YOUR SAW

Adjusting the Miter Gauge

The miter gauge includes indexing stops to allow you to quickly set the gauge to -45° , 0° , and $+45^\circ$. If necessary, you can adjust these indexing stops to increase the precision of your miter cuts.

To begin, loosen the miter gauge head by turning the locking handle counter-clockwise about $\frac{1}{2}$ turn (see Fig. 102).

Fig. 102



Next, for the indexing stop you want to adjust, loosen the corresponding hex nut on the bottom of the miter gauge head and turn the stop adjustment screw counter-clockwise several turns (see Fig. 103). Place the miter gauge in either the left or right miter slot, and set a combination square to the desired angle (e.g., -45° , 0° , or $+45^\circ$). Position one leg of the square flush against the blade and rotate the miter gauge head until it is flush against the other leg of the square.

Next, turn the handle clockwise until tight to lock the miter gauge head at the correct angle. Make sure the indexing pin is pressed in toward the miter gauge bar, then turn the stop adjustment screw clockwise until it hits against the indexing pin. Finally, tighten the hex nut against the indexing stop flange to prevent the screw from moving.

Repeat the above process for the other indexing stops if desired.

Fig. 103

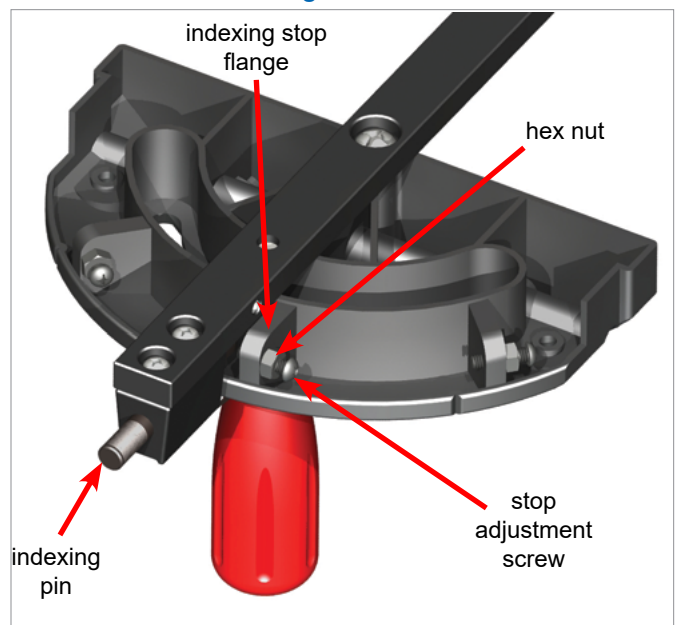

MAINTENANCE

WARNING! Always turn off the main power switch and unplug the power cord before doing any maintenance on your saw.

The SawStop Safety System

The safety system performs continuous self-checks both before and during saw operation. If a problem is detected, the appropriate status code will be displayed on the LEDs on the switch box and the appropriate action should be taken. No other maintenance is required.

Brake Cartridge

The condition of the cartridge should be checked after approximately every 50 hours of saw use. The cartridge is sealed to prevent the entry of dust or other contaminants into the housing. While a small amount of dust within the housing will not affect its operation, you should replace the cartridge if a significant amount of dust is visible inside the clear plastic housing. This would indicate that the cartridge housing seal has been damaged. The brake cartridge requires no other maintenance.

WARNING! Do not use a brake cartridge if more than a small amount of dust can be seen inside the clear housing. If sawdust becomes packed inside the housing, the brake may fail to activate or may activate more slowly, thereby resulting in a serious personal injury.

Elevation and Tilt Mechanisms

The elevation and tilt gearing should be kept clean and well lubricated. Periodically check the condition of the elevation miter gears and threaded shaft, and the tilt worm gear and sector gear. If necessary, clean off any dust, dirt, pitch or other debris using a wire brush, and then re-apply a good quality, non-hardening grease.

Table and Extension Wings

The surface of the table and extension wings should be kept clean and free of any rust. If rust develops on the surface, you can remove it by spraying the surface with a light coat of WD-40® and scrubbing with a fine abrasive pad such as ScotchBrite® 7448 hand pads. To prevent the table from rusting, coat it with a surface protectant such as TopCote® or TopSaver™, available in many woodworking stores. If you do not plan to use the saw for an extended period of time, you can protect the table by applying a light coating of oil and then covering the table with wax paper.

Motor Belt

The motor belt should be checked periodically for wear or damage. Replace the belt if it is worn or damaged.

TROUBLESHOOTING

Problem	Possible Cause(s)	Solution
The motor will not start and both LEDs on the switch box are off.	1. There is no power to the saw.	1. Ensure that the electrical supply to the saw is on and that the correct voltage is being supplied.
	2. There is no brake cartridge installed in the saw.	2. Install the brake cartridge.
	3. The brake cartridge is defective.	3. Replace the brake cartridge with a new cartridge.
The motor will not start and at least one LED on the switch box is on.	1. The safety system has detected a system error and is displaying an error code on the LEDs.	1. Consult the list of System Status Codes to determine the cause of the error and the corrective action.
	2. The cartridge is defective.	2. Try a different brake cartridge.
	3. The thermal overload switch cut power to the motor to prevent overheating.	3. Press the thermal overload reset button on the side of the contactor box.
	4. The motor is unplugged from the saw.	4. Plug the motor cord into the matching cord extending from the rear of the cabinet.
The motor stopped unexpectedly during use but the brake did not activate.	1. The Start/Stop paddle was bumped.	1. Ensure the Start/Stop paddle is in the <i>OFF</i> position and restart the saw.
	2. The material being cut is overloading the safety detection system (e.g., green or wet wood).	2. Use different wood or cut in Bypass Mode.
	3. The safety system has detected a system error and is displaying an error code on the LEDs.	3. Consult the list of System Status Codes to determine the cause of the error and the corrective action.
	4. Electrical power to the system was lost at least temporarily.	4. Ensure that the electrical supply to the saw is on and that the correct voltage is being supplied.
	5. The cartridge is defective.	5. Try a different brake cartridge.
The brake activated even though there was no accidental contact.	1. Some electrically conductive material contacted the blade, arbor or arbor pulley.	1. Make sure no metal or other conductive material is touching the blade, arbor or pulley. If you are trying to cut a conductive material, use Bypass Mode.
	2. The spreader or riving knife came into contact with the blade.	2. Ensure that the spreader or riving knife is accurately aligned and securely clamped in place. There should be gap of at least 3-8 mm between the blade and the spreader or riving knife.
Cannot turn the saw on in Bypass Mode.	1. The sequence for starting the saw in Bypass Mode was not completed.	1. Follow the steps for starting the saw in Bypass Mode exactly.
	2. The safety system has detected a system error and is displaying an error code on the LEDs.	2. Consult the list of System Status Codes to determine the cause of the error and the corrective action.
	3. The Bypass key is not fully seated.	3. Insert the Bypass Key fully and ensure it turns a full 90°.

TROUBLESHOOTING

Problem	Possible Cause(s)	Solution
Cannot remove the brake cartridge.	1. The cartridge key is still installed.	1. Remove the cartridge key.
	2. The cartridge is bound up on the pivot pin and the positioning pin.	2. Pry the cartridge off the pins with a blade wrench.
	3. The quick-release clamp handle is in the way.	3. Swing the clamp handle fully upward to clear the cartridge.
	4. The dust shroud is in the way.	4. Raise the blade elevation fully.
Cannot install the brake cartridge.	1. The holes in the cartridge shell are not aligned with the pivot pin and positioning pin.	1. Make sure the mounting holes in the cartridge are aligned with the pivot and positioning pins.
	2. There is debris on the pivot or positioning pins, or in the cartridge mounting holes.	2. Make sure the pins and mounting holes are clean and free of obstructions.
	3. The blade is interfering with the brake pawl.	3. Adjust the brake positioning bolt to move the cartridge mounting bracket away from the blade.
Cannot remove the cartridge key.	1. The cartridge key is not turned to the UNLOCKED position.	1. Turn the key clockwise until it stops.
	2. The shaft of the cartridge key is binding in the cartridge or on the cartridge mounting bracket.	2. Try turning and removing the key while pressing upward or downward on the key or cartridge.
Cannot install the cartridge key.	1. The key is not rotated properly to align with the keyhole in the cartridge.	1. Rotate the key so that the handle is pointing directly toward the brake pawl.
	2. The shaft of the cartridge key is binding in the cartridge or on the cartridge bracket.	2. Try installing the key while pressing upward or downward on the key or cartridge.
Cannot lower the blade below the table.	1. The lower elevation limit stop is not adjusted properly.	1. Adjust the lower elevation limit stop.
	2. Sawdust has accumulated within the trunnion assembly and on top of the lower elevation limit bolt.	2. Locate the top of the lower elevation limit bolt and ensure that there is no sawdust on top of it or around it.
The blade slows down when cutting, but does not stop.	1. The motor belt is worn or damaged.	1. Replace the motor belt.
	2. The blade is binding on the wood.	2. Ensure the spreader or riving knife is aligned with the blade. If using the rip fence, ensure it is aligned parallel to the blade.
	3. The blade is installed backwards.	3. Remove the blade and reinstall in the correct orientation.
	4. The voltage supplied to the motor is incorrect.	4. Ensure the motor is wired to match the power that is being supplied. If using an extension cord, ensure the extension cord is the correct gauge.

TROUBLESHOOTING

Problem	Possible Cause(s)	Solution
The blade hits the brake pawl during installation.	1. The brake position is adjusted too close to the blade.	1. Turn the brake positioning bolt counter-clockwise until the closest point between the brake pawl and the blade is about $\frac{1}{16}$ inch to $\frac{1}{8}$ inch.
	2. The blade is the wrong size.	2. Use only a 10 inch blade with a standard brake cartridge, or an 8 inch dado set with a dado cartridge.
The gears sound/feel rough when raising or lowering the blade.	1. There is dust or debris on the miter gears or elevation shaft.	1. Clean components and re-grease.
	2. The elevation locking knob has not been released.	2. Turn the elevation locking knob counter-clockwise to release the elevation hand-wheel.
The saw does not make accurate 45° or 90° cuts.	1. The tilt limit stops are not adjusted properly.	1. Adjust the tilt limit stops.
	2. The tilt angle indicator is not adjusted properly.	2. Adjust the tilt angle indicator.
	3. The miter gauge is not adjusted properly.	3. Adjust the miter gauge.
The material binds when making a rip cut.	1. The rip fence is not aligned with the blade.	1. Align the fence to the blade.
	2. The material is warped.	2. Select another piece of material.
	3. The feed rate is too high.	3. Try again at a lower feed rate.
	4. The spreader or riving knife is not aligned with the blade.	4. Align the spreader or riving knife.
The cuts are not clean or even.	1. The blade is dull.	1. Replace or sharpen the blade.
	2. The blade is coated with pitch, gum or other material.	2. Clean or replace the blade.
	3. The blade is not the correct blade for the material or cut.	3. Replace the blade.
The saw vibrates too much.	1. The blade is damaged or unbalanced.	1. Replace the blade.
	2. The floor is uneven.	2. Move the saw to a level, even surface.
	3. The bearings are worn.	3. Replace the bearings.
	4. The motor belt is worn.	4. Replace the motor belt.
The motor starts slowly and/or fails to reach nominal speed.	1. The voltage supplied to the motor is incorrect.	1. Ensure the motor is wired to match the power that is being supplied. If using an extension cord, ensure the extension cord is the correct gauge.

CONTRACTOR SAW SPECIFICATIONS

Overall saw dimensions (including the motor):	44" w x 39 ¹ / ₄ " d x 34 ³ / ₄ " h (table saw only) 61 ¹ / ₂ "w x 40 ¹ / ₂ "d x 34 ³ / ₄ "h (w/ Premium T-Style Fence Assembly) 69 ¹ / ₈ " w x 41" d x 34 ³ / ₄ " h (w/ T-Glide Fence System & 36" rails) 85 ¹ / ₄ " w x 41" d x 34 ³ / ₄ " h (w/ T-Glide Fence System & 52" rails)
Cabinet footprint:	25 ³ / ₄ " w x 27" d
Cast iron table:	20" w x 27" d, 44" w x 27" d (w/ extension wings)
Extension wing:	12" w x 27" d
Extension table (optional):	19 ³ / ₄ " w x 27" d (36" rails), 35 ³ / ₄ " w x 27" d (52" rails)
Weights (approx.):	225 lbs (table saw only) 245 lbs (w/ Contractor Fence Assembly) 310 lbs (w/ T-Glide Fence System, 36" rails & table) 335 lbs (w/ T-Glide Fence System, 52" rails & table) 35 lbs (optional cast iron extension wing)
Shipping weight (approx.):	240 lbs (table saw only)
Blade:	40-tooth, professional grade, ⁵ / ₈ " arbor
Blade diameter:	10"
Blade tilt:	Left
Blade kerf:	3 mm
Blade plate thickness:	2 mm
Max. depth of cut, blade at 0°:	3 ¹ / ₈ "
Max. depth of cut, blade at 45°:	2 ¹ / ₄ "
Max. rip, right of blade:	30 ¹ / ₂ " (w/ Contractor Fence Assembly) 36 ¹ / ₂ " (w/ optional 36" rails) 52 ¹ / ₂ " (w/ optional 52" rails)
Max. rip, left of blade:	16 ¹ / ₂ " (w/ Contractor Fence Assembly) 12 ¹ / ₂ " (w/ T-Glide Fence System)
Dado diameter:	8" (requires a separate brake cartridge and table insert)
Dado max. width:	29 ⁵ / ₃₂ "
Arbor diameter at blade:	⁵ / ₈ "
Main bearing size:	62 mm OD x 30 mm ID
Second bearing size:	52 mm OD x 25 mm ID
Table in front of blade (max. elevation):	10 ⁵ / ₈ "
Table behind blade (max. elevation):	7 ¹ / ₈ "
Arbor Runout:	0.001" maximum allowable runout
Table Flatness Measured Diagonally:	0.016" maximum gap
Blade Alignment with Miter Slot:	0.010" maximum displacement
Deviation of Miter Gauge Indexing Stops from actual angle:	±0.25°
Alignment between Spreader and Blade:	0.010" maximum difference
Miter slots:	T-shaped, ³ / ₄ " at top, 1" at bottom, ³ / ₈ " deep
Dust collection port diameter:	4"
Riving knife / spreader thickness:	2.3 mm
Blade guard:	polycarbonate, extends only 1" to right of blade
Standard Insert:	zero-clearance, phenolic core, melamine surfaces
Belts:	V-ribbed belt— motor belt is static dissipative
Handwheels:	6" diameter, cast aluminum with ABS handle
Motor Options:	1.75 hp, 60 Hz, dual voltage motor (model CNS175) 14A at 110-120V (pre-wired in this configuration) or 7A at 208-240V 1.75 hp, 50 Hz, 208-240V (model CNS175-AU) 1.75 hp, 50 Hz, 220V (model CNS175-CH)

CONTRACTOR SAW DIMENSIONS

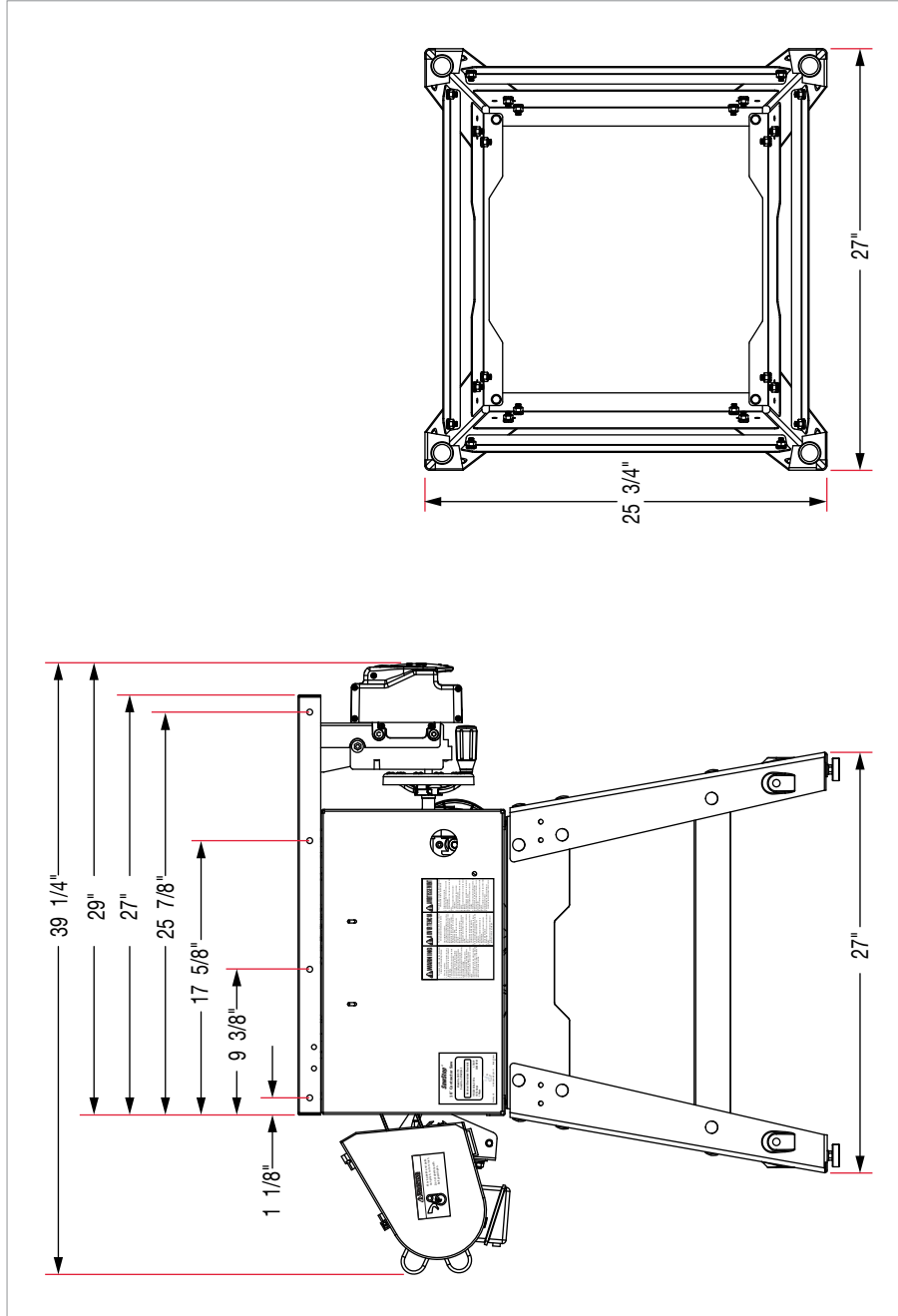

Fig. 105

Footprint

Left Side View

PUSH STICK CONSTRUCTION

Squares are 1 inch.

Pushstick should be $\frac{1}{2}$ inch to $\frac{3}{4}$ inch thick.

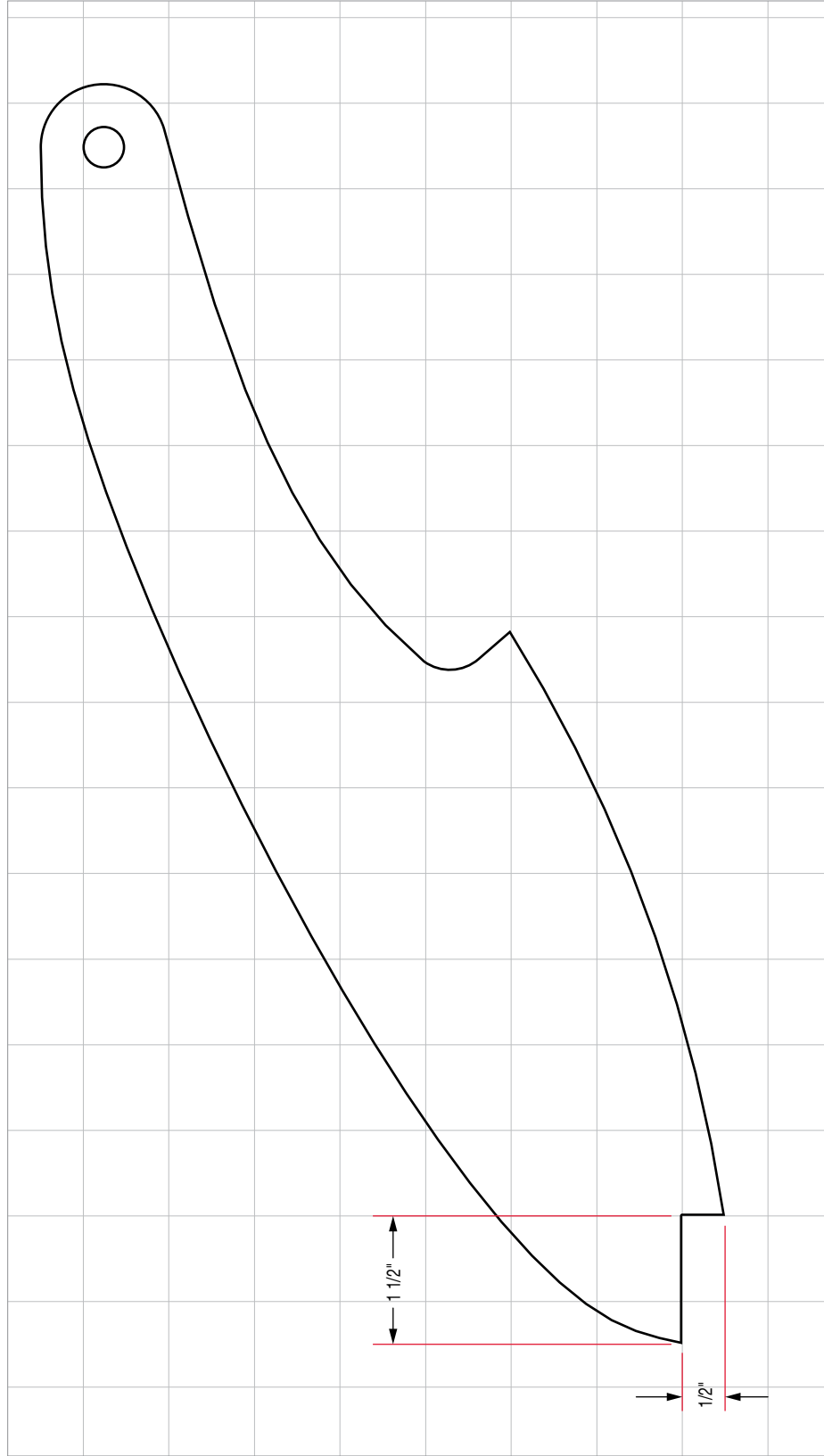

Fig. 106

This diagram illustrates a typical pushstick. Pushsticks should be constructed from material that is sturdy and electrically non-conductive such as scrap wood. Pushsticks should always be used when rip cutting pieces narrower than 6 inches.

AUXILIARY FENCE CONSTRUCTION

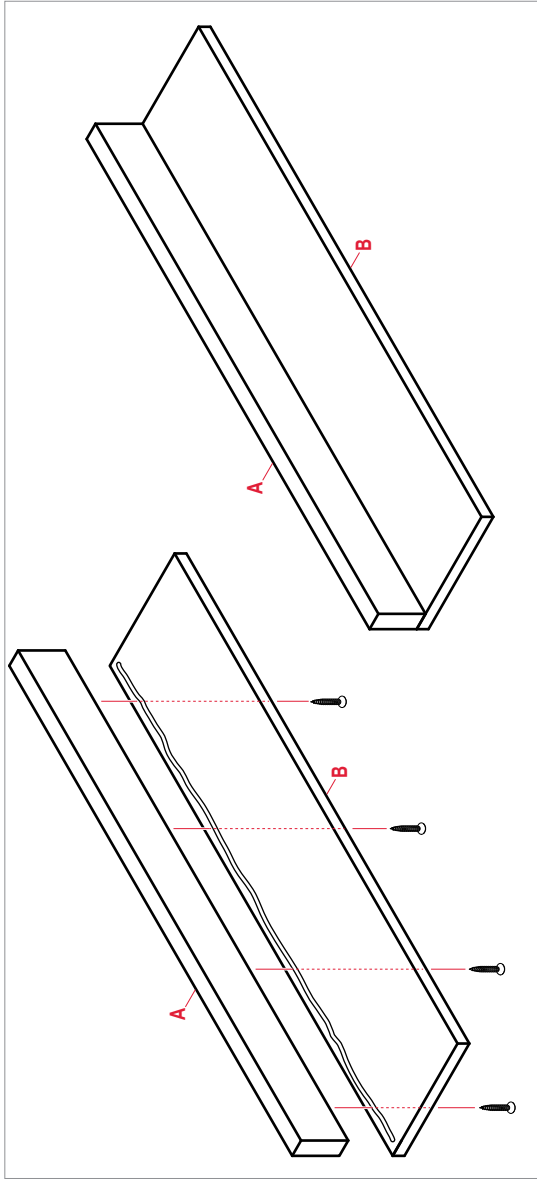
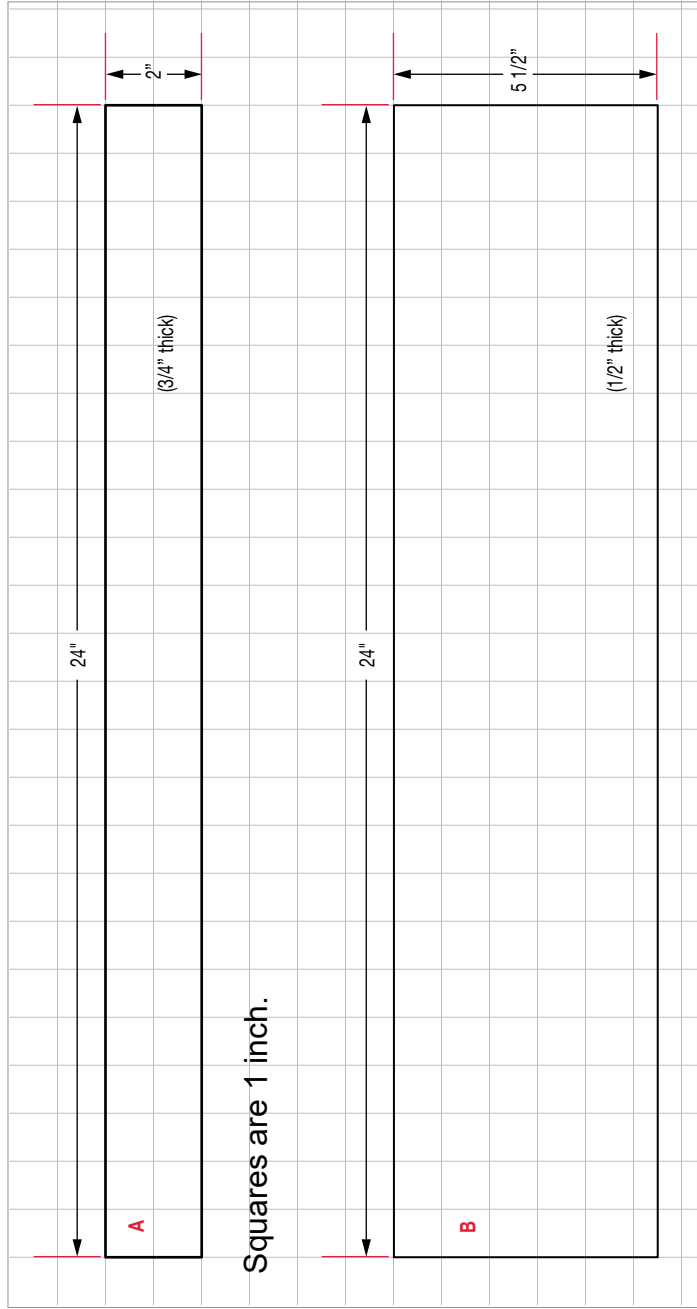
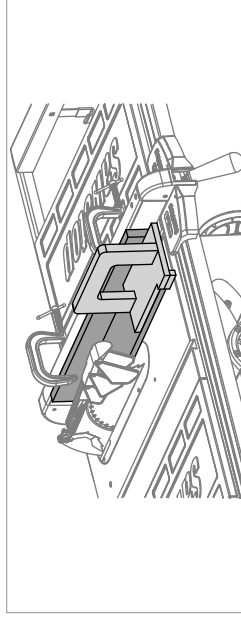

Fig. 107

This diagram illustrates a typical auxiliary fence for use with the push block shown [on page 83](#). Cut piece A out of $\frac{3}{4}$ inch thick hardwood and cut piece B out of $\frac{1}{2}$ inch thick plywood. Position piece A along the edge of piece B as shown in the drawing above, and attach it using wood glue and countersunk wood screws.



Squares are 1 inch.

To use the auxiliary fence, place it on the saw with piece B flat on the table top and piece A against the left side of the rip fence. Position the auxiliary fence so that the front edge of piece B is 1-2 inches back from the front edge of the table, and then clamp piece A securely to the rip fence. Position the rip fence so that the spacing between the left edge of piece B and the blade is the width you want to cut, and then lock the rip fence in place. Slide the workpiece along the edge of piece B closest to the blade. If your hand comes within 6 inches of the blade, remove your hand from the workpiece and use the push block to finish the cut, as shown in the drawing to the left.

PUSH BLOCK CONSTRUCTION

Squares are 1 inch.

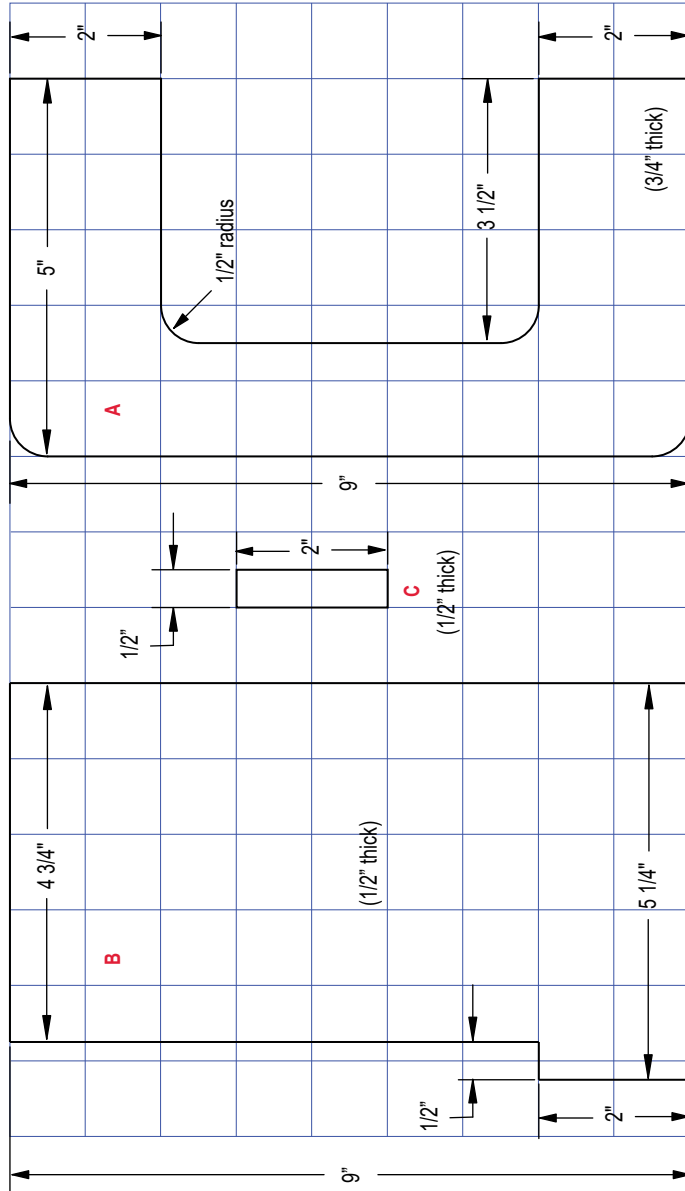
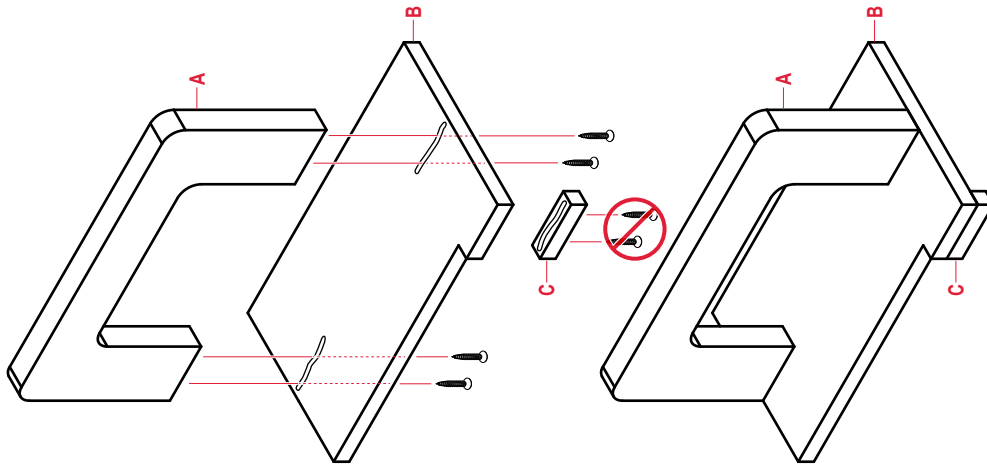

Fig. 108



This diagram illustrates a typical push block. It includes the three pieces shown here labeled A, B, and C. Cut piece A out of 3/4 inch thick hardwood and cut pieces B and C out of 1/2 inch thick plywood. Attach piece A to the center of piece B using wood glue and counter-sunk wood screws. Attach piece C to piece B as shown in the drawing to the left using wood glue only. Do not use metal fasteners to attach piece C to piece B.

FEATHERBOARD CONSTRUCTION

Squares are 1 inch.
Featherboard should be approximately $\frac{3}{4}$ inch thick.

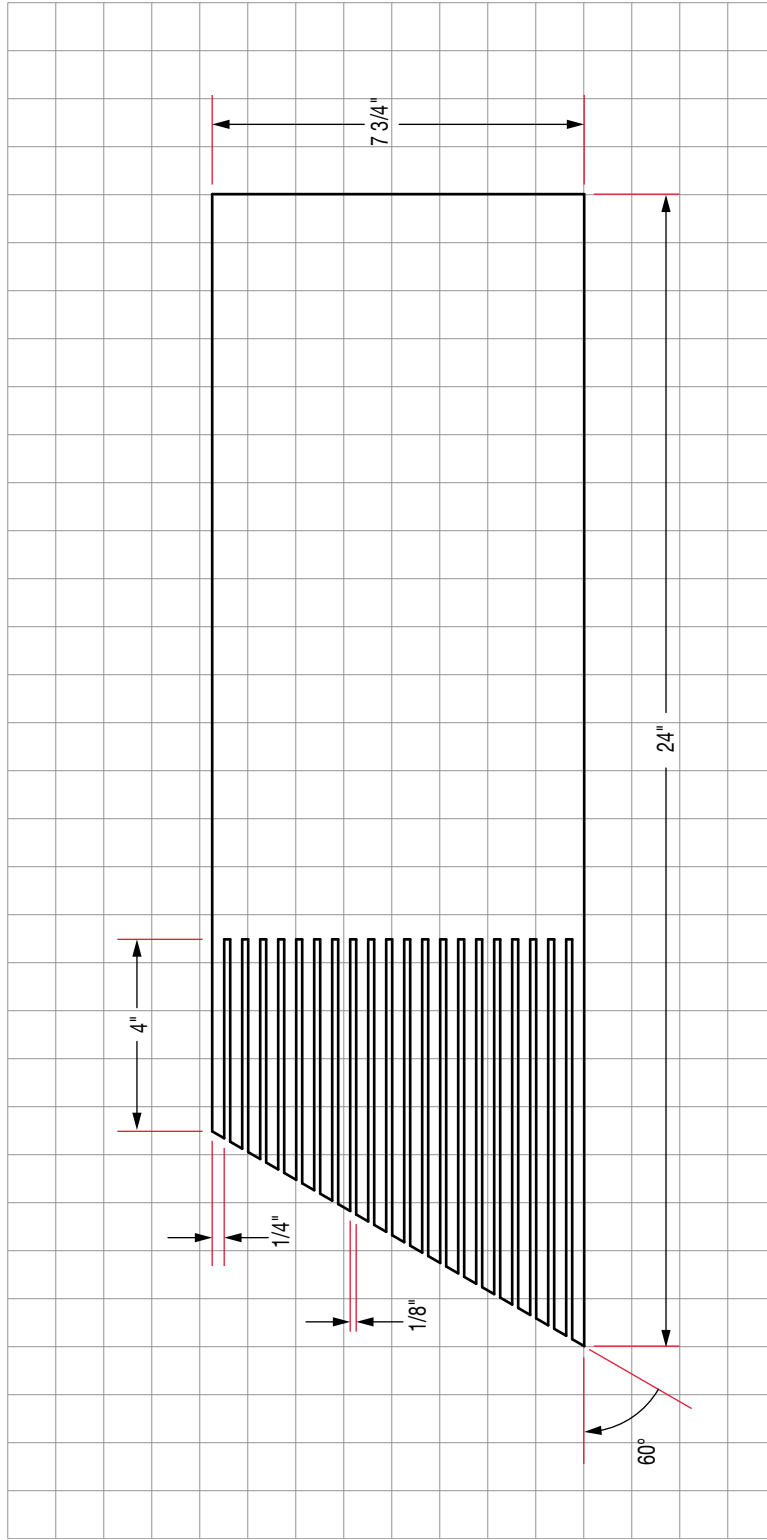

Fig. 109

This diagram illustrates a typical featherboard. Featherboards should be constructed from good quality wood that is free of knots. Use featherboards to help keep the material being cut in contact with the table and to help prevent kickback. Do not use featherboards when cutting with the miter gauge.

ACCESSORIES

SawStop recommends the following accessories for use with your SawStop® Contractor Saw. Contact your local authorized SawStop Dealer or SawStop at 1-866-SAWSTOP for more information.

1. SawStop Brake Cartridges:

Standard Brake Cartridge for 10 inch saw blades	p/n	TSBC-10R2 or TSBC-10R3
Dado Brake Cartridge for 8 inch dado sets	p/n	TSDC-8R2 or TSDC-8R3

2. Saw Blades:

24 Tooth Ripping Saw Blade	p/n	BTS-R-24ATB
40 Tooth Combination Saw Blade	p/n	CNS-07-148
60 Tooth Professional Saw Blade	p/n	CB104 184
Titanium Series 40-Tooth ATB Combination Rip Blade	p/n	BTS-R-40ATB
Titanium Series 80-Tooth HATB Plywood / Laminate Blade	p/n	BTS-P-80HATB

3. Table Inserts:

Phenolic Standard Zero-Clearance Table Insert Assembly - with lock-down lever	p/n	TSI-SLD
Phenolic Dado Zero-Clearance Table Insert Assembly - with lock-down lever	p/n	TSI-DLD

4. Rip Fences and Extension Tables:

Premium Fence Assembly (includes fence and rails)	p/n	TSA-PFA
T-Glide™ Fence System - Professional Series		
Fence	p/n	TGP-FA
36 Inch Rails	p/n	TGP-R36A
36 Inch Extension Table (for use with 36 inch rails)	p/n	TGP-T36A
52 Inch Rails	p/n	TGP-R52A
52 Inch Extension Table (for use with 52 inch rails)	p/n	TGP-T52A

5. Miscellaneous Accessories:

Micro-Guard Blade Guard Assembly	p/n	TSG-MG
Dust Collecting Blade Guard Assembly	p/n	TSG-DC
Over-Am Dust Collection	p/n	TSA-ODC
Miter Gauge Assembly	p/n	CNS-07-226
Cast Iron Extension Wing	p/n	CNS-07-017
Cast Iron Extension Wing Mounting Hardware	p/n	CNS-07-258
Mobile Base	p/n	MB-CNS-000
Revolution Miter Gauge	p/n	TSA-RMG
Scale Miter Gauge	p/n	TSA-SMG
Dust Collection Panel Assembly	p/n	CNS-DCP
Sliding Table Attachment	p/n	TSA-SA48

INDEX

A

Accessories: **8, 9, 13, 85**

Accidental Contact: **1, 5, 11–13, 42, 45, 55, 57, 61, 62, 75**

Activation of Brake (see Brake, activation)

Adjustments

blade height: **41**

blade tilt (bevel): **41, 65–66**

brake position: **12, 27, 30–31, 45, 61**

limit stops

elevation: **41, 63–64**

tilt: **41, 65–66**

miter gauge: **50, 73**

quick-release clamp: **69, 72**

table insert: **67–68**

Aligning the Riving Knife and Spreader: **69–71**

Ambient Temperature: **44**

Anti-Kickback Pawl(s): **47–48, 54, 70**

Arbor

block: **27, 30, 60, 62, 63–64**

diameter: **78**

nut: **13, 27, 29**

runout: **78**

washer: **13, 27, 29**

Assembling Your Saw: **16–25**

Auxiliary Fence: **53, 82**

B

Belts, Static Dissipative: **78**

Bevel (see Tilt)

Blade(s)

abrasive blade: **12, 29, 45**

coating(s): **12, 29**

coast down: **11, 44–45**

dado set (see Dado, set)

damaged: **12, 77**

elevation (see Elevation)

kerf: **13, 29, 49, 69–70, 78**

non-conductive: **11–13, 29, 45**

retraction: **11, 13, 34, 62**

standard blade: **12–13, 29, 57**

wrench: **15, 26, 29, 60**

Blade Guard

anti-kickback pawl: **47–48, 54, 70**

guard: **8, 12, 15, 26, 32–33, 47–48, 53, 78**

installation: **32–33**

spreader: **8, 26, 32–33, 47–47, 54, 69–71, 72, 75, 76, 77, 78**

using: **47–48**

INDEX

Blade Guard Clamp (see Quick-Release Clamp)

Blade Spacing Adjustment Gauge: **31**

Brake

- activation: **12–13, 46, 60, 62, 64, 75**
- cartridge: **5, 11–13, 27, 45, 57–61, 62, 74, 75, 76, 77**
- cartridge key: **27, 44–45, 57, 59–60, 61, 76**
- dado: **12–13, 29, 57, 77**
- changing the brake cartridge: **58–60, 61**
- pawl: **11, 55, 57, 60, 61, 62, 76, 77**
- position adjustment: **30–31**

Brake Positioning Bolt: **27, 30, 76, 77**

Bypass

- key: **26, 55, 75**
- mode: **5, 11–13, 44–46, 55, 75**

C

Cabinet Saw

- dimensions: **79–80**
- specifications: **78**

Cartridge (see Brake Cartridge)

Cartridge Key :**27, 44–45, 57, 59–60, 61, 76**

Clamping Handle (for spreader or riving knife): **27, 32–33, 58**

Coast-down: **11, 44–45**

Contact Box Assembly: **35–36, 38–40, 43, 75**

Premium Fence Assembly: **8, 25, 52, 53–54**

Cross-cuts: **49–50, 51**

Cutting

- cross-cuts: **49–50, 51**
- narrow cuts: **32, 47**
- non-through cuts: **12, 32, 49, 54, 70**
- rabbet: **32, 47, 70**
- rip cuts: **8, 25, 47, 52, 53–54, 77**

D

Dado

- brake cartridge: **12–13, 29, 57, 77, 85**
- cuts: **12, 28, 47, 49, 54, 57**
- insert: **29, 85**
- set: **12–13, 28, 29, 33, 57, 60, 61, 77, 78, 85**

Depth of Cut: **50, 78**

Detection of Accidental Contact: **1, 5, 11–13, 42, 44–46, 62**

Dimensions: **79–80**

Dust

- collection: **34**
- hazard: **6, 34**

INDEX

port: **27, 34, 78**

Dust Shroud: **13, 27, 34, 63, 76**

E

Electrical

grounding: **6–7, 35, 38, 39, 40**

power connection: **6–7, 10, 13, 35, 36, 38, 39–40, 42, 75**

schematics: **37, 40**

Elevation

changing the blade elevation: **41**

elevation hand-wheel: **15, 22, 26, 41, 77, 78**

elevation locking knob: **22, 41, 77**

elevation plate: **27**

limit stops: **41, 63–64**

miter gears: **74**

Extension Cord Recommendations: **6, 35, 38**

Extension Wing(s): **14, 24–25, 26**

F

Featherboard(s): **33, 54, 84**

Fence: **8, 13, 25, 51, 52, 53–54, 56, 88, 76, 77, 78, 85**

Freehand Cutting: **8, 50, 53**

Front Trunnion: **27**

Front Trunnion Bracket: **27**

G

Get to Know Your Saw: **26–27**

Green Wood: **46, 75**

Guard (see Blade Guard)

H

Hand-wheel(s): **15, 22, 26, 41, 77, 78**

I

Insert (see Table Insert)

K

Kerf: **13, 29, 49, 69–70, 78**

Kickback: **32, 47–48, 51, 54**

INDEX

L

LED(s) (see Status Codes)

Lights (see Status Codes)

Limit Stop(s)

elevation: **63–64**

tilt: **65–66**

Lockout key: **43**

M

Main Power Switch: **9, 11, 28, 29, 30, 42–43, 44–46**

Maintenance: **5, 74**

Material Conductivity Test: **13, 46**

Miter Gauge

adjustment: **73**

indexing pin: **50, 73**

index stop(s): **50, 73**

slot(s): **26**

using: **26, 49–50, 51**

Mobile Base: **19, 56, 85**

Motor: **11–12, 15, 23–24, 27, 35, 36, 42–43, 45, 75, 76, 77**

Motor Belt: **13, 15, 24, 27, 36, 45, 74, 76, 77**

O

Overheat (see Thermal Overload Switch)

Overload (of the detection system): **44, 46**

P

Plug / Power Cord on a 208-240V Saw: **38–40**

Power Switch (see Main Power Switch)

Preparing Your Saw for Use: **28–40**

Protectant (see TopCote®; see TopSaver™)

Push Block: **33, 53–54, 83**

Push Stick: **8, 12, 26, 33, 53–54, 81**

Q

Quick-Release Clamp: **27, 32, 33, 69–70, 72, 76**

R

Rear Trunnion: **27, 36, 64**

Rear Trunnion Bracket: **27**

Retraction: **11, 13, 34, 62**

INDEX

Re-Wiring the Saw for 208-240V Power: **36, 37**

Rip

cutting: **8, 53–54**

fence: **8, 25, 52, 53–54, 76, 77, 78, 85**

narrow rip cuts: **47**

Riving Knife

adjusting: **69–71, 72**

installation: **32–33**

using: **26, 27, 47, 49, 75, 76, 77**

S

Safety: **6–9, 11–13**

Saw Placement: **28**

SawStop Safety System

activation: **12–13, 46, 57, 60, 62, 64, 70, 72, 75**

Bypass Mode: **5, 11–13, 44–46, 55, 75**

system status codes(s): **42, 44–46, 55, 61, 62, 74, 75**

ScotchBrite®: **74**

Shipping Weight: **78**

Specifications: **78**

Spin Blade (see Start/Stop Paddle)

Splitter (see Spreader)

Spreader: **8, 26, 32, 33, 47, 54, 69–71, 72, 75, 76, 77**

Stand Assembly: **16–19**

Standby Mode: **44–45, 55**

Start/Stop Paddle: **42–43, 44–46, 55, 58, 75**

Static Electricity: **13**

Status Codes: **42, 44–46, 55, 61, 62, 74, 75, 78**

Switch (see Main Power Switch)

Switch Box: **14, 25, 26, 42–43, 44, 75**

System Status Code(s): (see Status Codes)

T

T-Glide™ Fence System - Professional Series: **52, 56, 78, 85**

Table Inserts

adjustment: **67–68**

dado insert: **12, 28, 29, 85**

removal and installation: **28**

standard insert: **14, 26, 28, 85**

Thermal Overload Switch: **26, 43, 45, 75**

Thin-Kerf blade: **70**

Tilt

adjust tilt limit: **65–66**

angle: **41**

INDEX

angle indicator: **26, 41, 66, 77**
angle scale: **26, 41**
hand-wheel: **15, 22, 26, 41, 78**
limit stop: **65–66**
locking knob: **22, 41**

TopCote®: **74**

TopSaver™: **74**

Troubleshooting: **75–77**

Tunion (see Front Trunnion; see Rear Trunnion)

U

Unpacking Your Saw: **14–15**

Using Your Saw: **41–57**

W

Warning Labels: **10**

Warranty: **1, 5, 13, 35**

WD-40®: **74**

Wet Wood: **13, 44, 46, 75**

Wiring (see Electrical, power connection and schematics)

Wood Stop: **47**

Worm Gear: **74**

Z

Zero-Clearance Table Insert (see Table Inserts)

NOTES

NOTES

SawStop, LLC
11555 SW Myslonny Street
Tualatin, Oregon 97062 USA
SawStop.com

Technical Support	503-582-9934	service@sawstop.com
Parts Store	503-486-6923	parts@sawstop.com
Sales / Customer Service	503-595-2665	sales@sawstop.com